



INSTRUCTIONS

-J03241

REV. 5-20-2005

Kit Numbers 59802-05, 58751-05, 57199-05

QUICK RELEASE DETACHABLE WINDSHIELD KIT

General

These windshield kits fit 1984 and later FXST, FXSTC and FXSTB models and 1993 to 2005 FXDWG models.

Kit No.	Description
59802-05	Standard height, clear windshield
58751-05	Standard height, smoked windshield
57199-05	Compact low profile, smoked windshield

See the Service Parts illustration for kit contents.

Installation

WARNING

The rider's safety depends upon the correct installation of this kit. If the procedure is not within your capabilities or you do not have the correct tools, have a Harley-Davidson dealer perform the installation. Improper installation of this kit could result in death or serious injury. (00308a)

NOTE

Cover the front fender and the front of the fuel tank with clean shop towels to prevent scratching. Damage to the finish could result.

Prepare Motorcycle — All models except FXSTB

1. For all models except FXSTB: Relocate clutch cable to the inside of the handlebars as follows:
2. See Figure 1. Slide rubber boot off cable adjuster. Adjuster is located approximately halfway along clutch cable by the front frame downtube.
3. Holding cable adjuster with 1/2 inch wrench, loosen jam nut using a 9/16 inch wrench. Back jam nut away from cable adjuster. Move adjuster toward jam nut to introduce a large amount of free play at the hand lever.
4. Remove small snap ring from pivot pin groove at bottom of clutch lever bracket. Remove pivot pin and clutch hand lever from bracket. Remove anchor pin and clutch cable eyelet from clutch hand lever.
5. See Figure 2. Reroute clutch cable to the inside of the handlebars and reconnect clutch cable to clutch lever.
6. See Figure 3. Turn cable adjuster away from jam nut until slack is eliminated at hand lever. Pull clutch cable ferrule away from clutch lever bracket to check free play. Turn cable adjuster as necessary to obtain 1/16 to 1/8 inch (1.6-3.2 mm) free play between end of cable ferrule and clutch lever bracket.
7. Hold adjuster with 1/2 inch wrench. Using 9/16 inch wrench, tighten jam nut against cable adjuster. Cover cable adjuster mechanism with rubber boot.

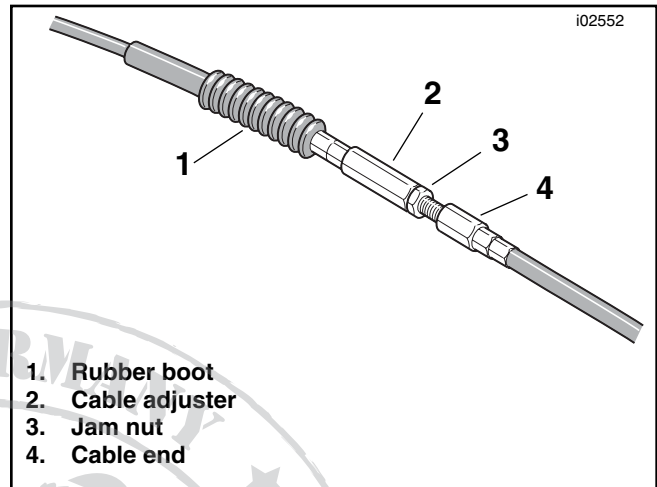

Figure 1. Clutch Cable Adjuster

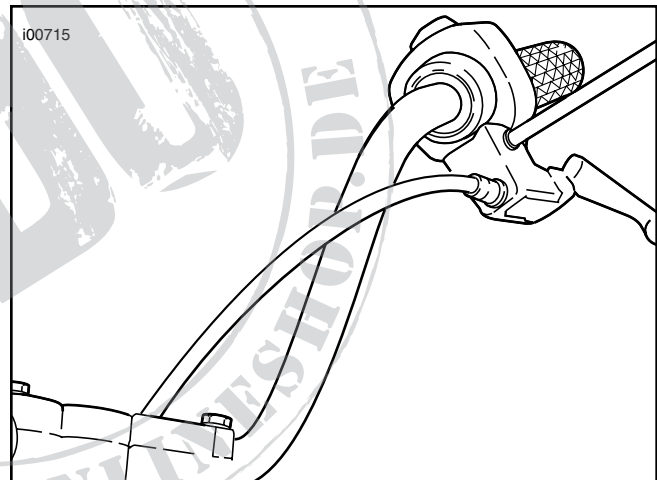

Figure 2. New Clutch Cable Routing

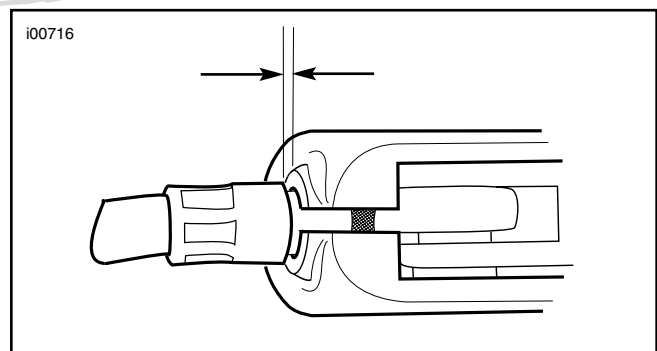

Figure 3. 1/16-1/8 inch (1.6-3.2 mm) Clutch Cable Free Play

- If necessary, reposition the clutch cable mount ties attached to the frame downtube to best allow the clutch cable to move naturally when the handlebars turn fully from left to right fork locks. Cycle the hand lever several times to confirm.

⚠ WARNING

After relocating clutch cable, check that clutch hand lever opens and closes smoothly when handlebars are turned fully left or right. Slow clutch lever response could result in loss of control and death or serious injury.

⚠ WARNING

Be sure that steering is smooth and free without interference. Interference with steering could result in loss of vehicle control and death or serious injury. (00371a)

Turn Signal Relocation — All Models

Relocate the turn signals according to the instructions included in the Turn Signal Relocation Kit, item 23.

Assemble the Clamps to the Windshield — All Models

- See Figure 4. Remove the windshield sub-assembly from the packaging and place face down on a clean, soft surface with the mount brackets facing upward.
- See the Service Parts illustration. Remove both the clamp and hardware kits from the packaging, and separate similar parts in preparation for assembly. Note that the lower clamps are exactly alike, and the left and right upper clamps can be identified by extensions that point upwards.
- See Figure 5. Assemble the clamp assemblies and hardware stacks.

⚠ WARNING

The cupped side of the Belleville (cone) washers must face each other and sandwich the windshield mount brackets at each mount point. Failure to orient washers correctly can reduce windshield's ability to break away in a collision, which could result in death or serious injury.

- See Figure 5. One clamp at a time, with the clamp facing upward and inboard of the windshield bracket (2), tighten the shoulder bolts (1) enough to hold the clamp orientation to the windshield during mounting of the windshield to the bike. The bolts will be fully tightened later.

Install the Windshield — All Models

NOTE

Keep front wheel straight to prevent brackets from scratching fuel tank.

- Make sure all four clamps are in the "open" position, then bring the windshield (with the clamp side away from you) to the front of the bike.

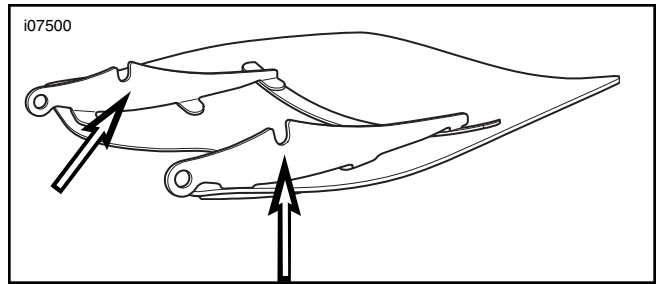

Figure 4. Windshield Mounting Brackets

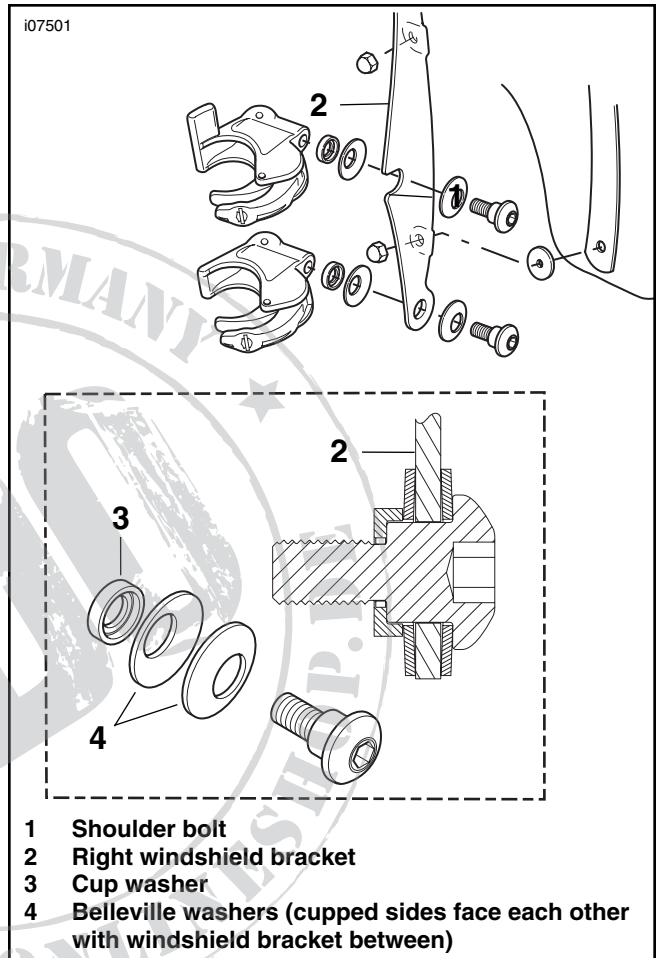

Figure 5. Windshield Mounting Clamp

NOTE

The Lexan® windshield is fairly flexible and can be bent to spread the clamps away from the headlamp to ease installation to the bike. Take care not to scratch the headlamp housing with the clamps while positioning the windshield to the fork sliders.

- Straddle the front fender. Center the windshield around the headlamp and seat the clamps onto the fork sliders.
- Starting at the bottom (either side) and with the shoulder bolts just a little more than finger tight, close each clamp, taking note that the clamps self-align to the fork sliders and to each other.

⚠ WARNING

Do not tighten the shoulder bolts beyond the recommended torque. Over-torquing may cause the clamp to twist on the fork slider, yielding the clamp jaw. A yielded clamp may not carry a preload on the fork slider and cause the windshield to come loose during use. A loose or rattling windshield may cause rider distraction, which could result in loss of control of vehicle and death or serious injury.

4. With the windshield clamps now clamped to the fork sliders, make sure that the shoulder portion of the shoulder bolts are fully seated in each windshield bracket location. Torque each shoulder bolt to 60 **in-lbs** (6.7 Nm).
5. Turn the handlebars fully to the left and right fork stops to confirm that the throttle cables move freely.

Removing the Windshield — All Models

To remove the windshield, open the four clamps in any sequence. Take care to not scratch the headlamp housing or fuel tank as noted during installation.

When storing the windshield, place in a location where the windshield clamps will receive the greatest protection. Keep from locations where the windshield may be impacted or dropped. Do not stack anything on top of the assembly.

Prior to re-installation after any storage period, inspect the clamps and hardware for fastener preload and cleanliness. Each clamp should have a pair of rubber gaskets in the clamp saddle that mates to the fork slider, and should cycle open and closed freely.

Care and Cleaning

CAUTION

Harley-Davidson windshields are made of Lexan. Lexan is a more durable and distortion-resistant material than other types of motorcycle windshield material, but still requires attention and care to maintain. Failure to maintain Lexan properly can result in damage to the windshield. (00230a)

- Do not use harsh chemicals including rain sheeting products on Harley-Davidson windshields. They can cause dulling or hazing. If you want to use a protectant on your windshield, use Harley Glaze Polish and Sealant® or Novus Plastic Cleaner/Protectant.
- Do not use benzine, paint thinner, gasoline or any other type of harsh cleaner on the windshield. Doing so will damage the windshield surface.
- Do not clean Lexan® in hot sun or high temperature. Powdered, abrasive or alkaline cleanser will damage the windshield.
- Sunlight reflections off of the inside curvature of a windshield can, at certain times of the day, cause extreme heat build-up on motorcycle instruments. Exercise care in parking. Park facing the sun, place an opaque object over the instruments, or adjust the windshield to avoid reflections.
- Do not use benzine, paint thinner, gasoline or any other cleaning agents on the clamp gaskets. Doing so will damage gasket surfaces.

NOTE

Covering the windshield with a clean, wet cloth for about 15 minutes before washing will make dried bug removal easier.



Service Parts

Part Number See page 1.

Date 5/05

Quick Release Windshield Kits

i07502

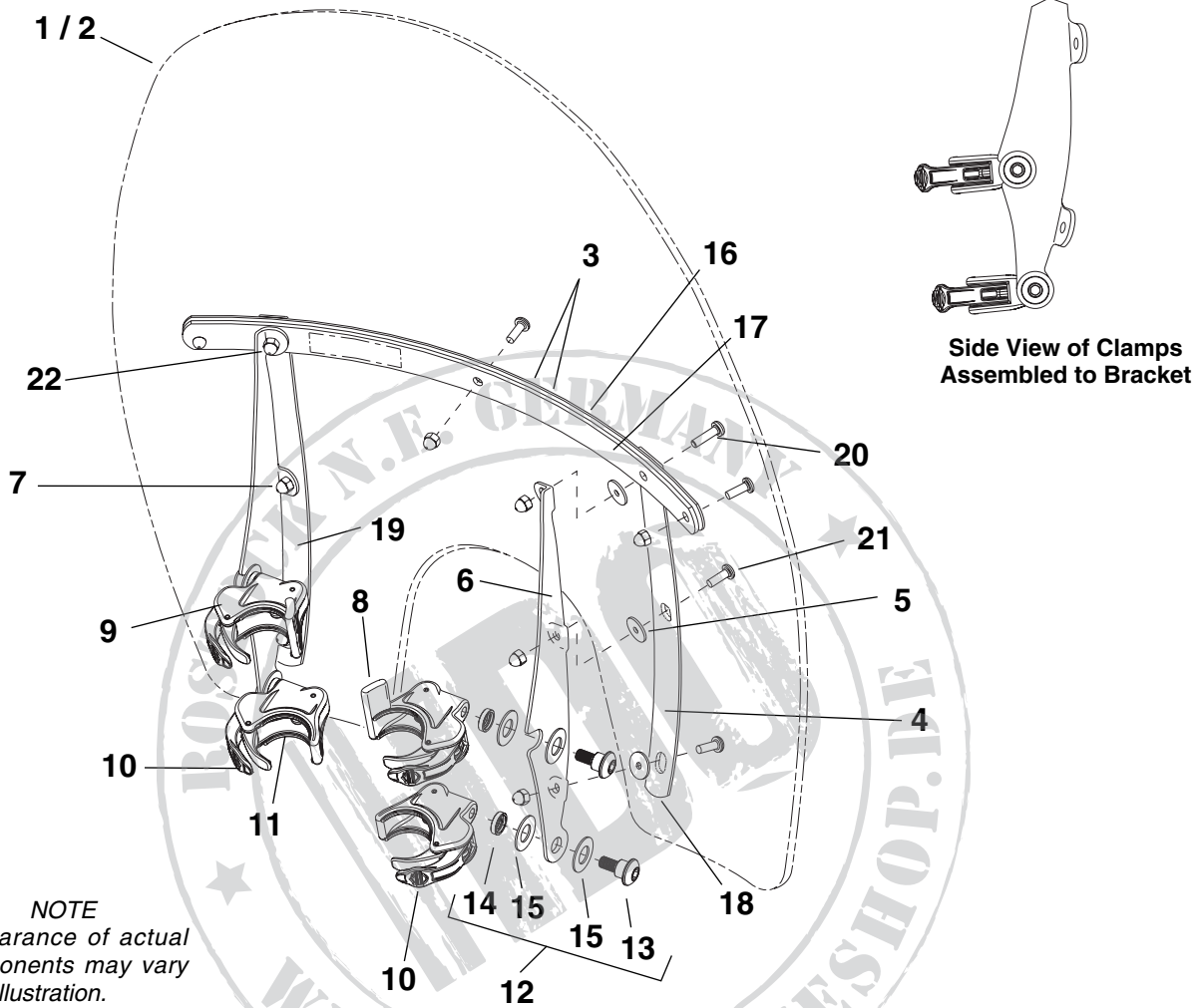

NOTE
Appearance of actual components may vary from illustration.

Item	Description (Quantity)	Part No.	Item	Description (Quantity)	Part No.
1	Windshield service kit (includes items 2 through 5) for Kit 59802-05 (compact, clear) for 58751-05 (compact, smoked) for 57199-05 (low profile, smoked)	58750-05	12	Hardware kit, windshield mount (4) (includes items 13 through 15)	58790-04
2	Windshield	Not sold	13	Shoulder screw, button head	Not sold
3	Tape, horizontal (2)	58052-78	14	Spacer, cup washer	Not sold
4	Tape, vertical (2)	59804-05	15	Belleville washer (2)	Not sold
5	Washer, rubber, black (6)	58152-96	16	Brace, horizontal, outer	58051-78A
6	Bracket, windshield mount, right	59855-05	17	Brace, horizontal, inner	58050-78A
7	Bracket, windshield mount, left	59844-05	18	Brace, vertical, right-hand	59809-05
8	Clamp assembly, tool-less release, right-hand upper (includes two of item 11)	59868-05	19	Brace, vertical, left-hand	59808-05
9	Clamp assembly, tool-less release, left-hand upper (includes two of item 11)	59859-05	20	Screw, button head, Torx, with lock patch, #12-24 x 13/16 in (2)	2452
10	Clamp assembly, tool-less release (2) (includes two of item 11)	58740-05	21	Screw, button head, Torx, with lock patch, #12-24 x 5/8 in (7)	2921
11	Gasket (8, 2 per clamp)	58791-04	22	Acorn nut, #12-24 (chrome) (9)	7651
			23	Turn signal relocation kit (not shown) See instructions provided in kit for kit contents.	58742-05