



INSTRUCTIONS

-J03588

REV. 2008-11-21

DETACHABLE WINDSHIELD AND QUICK-CLAMP DOCKING KIT

GENERAL

Kit Number

58444-06, 58413-06, 58387-06, 58348-06, 58347-06, 58346-06, 57609-08, 57340-08, 57338-08, 57301-06, 57300-06, 57016-06, 57015-06, 58630-09, 58617-09

Models

For model fitment information, see the P&A Retail Catalog or the Parts and Accessories section of www.harley-davidson.com (English only).

Table 1. Models

Kits	Contents
57015-06	Touring, Clear windshield, FXD
57016-06	Touring, Smoked windshield, FXD
58346-06	Standard height, clear windshield, FXD
58347-06	Standard height, smoked windshield, FXD
58348-06	Low profile, smoked windshield, FXD
58387-06	Standard height, clear windshield, FXDWG
58413-06	Standard height, smoked windshield, FXDWG
58444-06	Low profile, smoked windshield, FXDWG
57300-06	Super Sport, smoked windshield, FXD
57301-06	Super Sport, clear windshield, FXDWG
57609-08	Standard Height, Clear, cut for Auxiliary Lamps, FXD
57340-08	Low profile, smoked windshield, twin lamp, FXDF
57338-08	Standard height, clear windshield, twin lamp, FXDF
58630-09	Standard height, clear windshield, black braces, FXDF
58617-09	Low profile, clear windshield, black braces, FXDF

Kit Contents

See Figure 3 and Table 2, Figure 4 and Table 3, Figure 5 and Table 4, Figure 6 and Table 5.

INSTALLATION

WARNING

The rider's safety depends upon the correct installation of this kit. If the procedure is not within your capabilities or you do not have the correct tools, have a Harley-Davidson dealer perform the installation. Improper installation of this kit could result in death or serious injury. (00308a)

NOTE

Cover the front fender and the front of the fuel tank with clean shop towels to prevent scratching. Damage to the finish could result.

Assemble the Clamps to the Windshield

1. See Figure 1. Remove the windshield sub-assembly from the packaging and place face down on a clean, soft surface with the mount brackets facing upward.

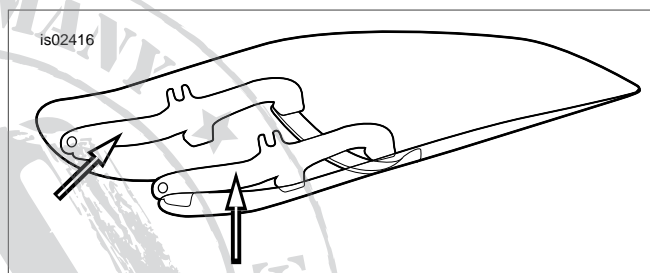

Figure 1. Windshield Mounting Brackets

2. See Figure 3, Figure 4, and Figure 5. Remove both the clamp and hardware kits from the packaging, and separate similar parts in preparation for assembly.
3. See Figure 2. Pre-assemble the clamp assemblies (5) and hardware stacks.

WARNING

The cupped side of the Belleville (cone) washers must face each other and sandwich the windshield mount brackets at each mount point. Failure to orient washers correctly can reduce windshield's ability to break away in a collision, which could result in death or serious injury. (00422b)

4. One clamp at a time, with the clamp (5) facing upward and inboard of the windshield bracket (2), tighten the shoulder bolts (1) enough to hold the clamp orientation to the windshield during mounting of the windshield to the motorcycle. The bolts will be fully tightened later.

NOTE

Keep front wheel straight to prevent brackets from scratching fuel tank.

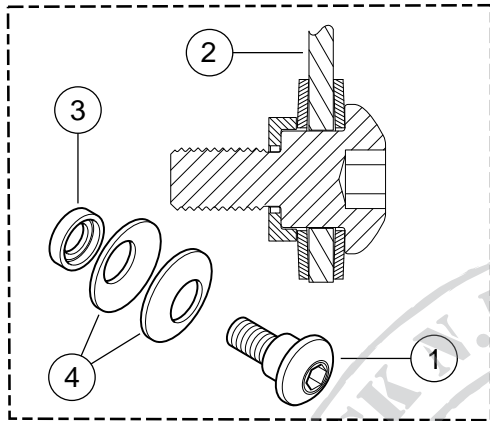
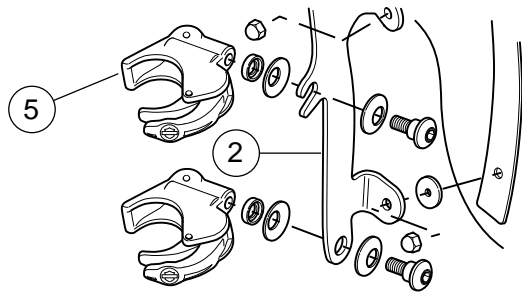

1. Shoulder bolt
2. Right windshield bracket
3. Cup washer
4. Belleville washers (cupped sides face each other with windshield bracket between)
5. Clamp, windshield mount

Figure 2. Windshield Mounting Clamp

Install the Windshield

5. Make sure all four clamps are in the "open" position, then bring the windshield (with the clamp side away from you) to the front of the motorcycle.

NOTE

The Lexan® windshield is fairly flexible and can be bent to spread the clamps away from the headlamp to ease installation to the motorcycle. Take care not to scratch the headlamp housing with the clamps while positioning the windshield to the fork sliders.

6. Straddle the front fender, center the windshield around the headlamp and seat the clamps onto the fork sliders.
7. Starting at the bottom (either side) and with the shoulder bolts just a little more than finger tight, close each clamp, taking note that the clamps self-align to the fork sliders and to each other.

CAUTION

Do not exceed recommended torque when installing mounting screws. Damage to windshield can result. (00385a)

NOTE

Do not tighten the shoulder bolts beyond the recommended torque. Over-torquing may cause the clamp to twist on the fork slider, yielding the clamp jaw. A yielded clamp may not carry

a preload on the fork slider and cause the windshield to come loose during use.

8. With the windshield clamps now clamped to the fork sliders, make sure that the shoulder portion of the shoulder bolts are fully seated in each windshield bracket location. Tighten each shoulder bolt to 60 in-lbs (6.7 Nm).

WARNING

Improper installation of accessories or loading of cargo can affect motorcycle stability and handling, which could result in death or serious injury. (00455b)

WARNING

Failure to provide adequate clearance between stationary and moving parts can cause loss of control, which could result in death or serious injury. (00378a)

NOTE

Inspect windshield upon completion of installation. Be sure windshield mounting does not restrict full left or full right movement of front fork assembly. If restriction does occur, adjust windshield as needed until proper clearance is obtained. Have experienced Harley-Davidson service personnel correct any problems before riding with this accessory installed.

NOTE

Check mounting hardware periodically. Never ride with loose mounts. A loose mounting causes extra stress on all other mounts, as well as the windshield itself, and could result in premature failure of components.

Removing the Windshield

To remove the windshield, open the four clamps, in any sequence, and reverse the preceding installation procedures. Take care to not scratch the headlamp housing or fuel tank as noted during installation.

When storing the windshield, place in a location where the windshield clamps will receive the greatest protection. Keep from locations where the windshield may be impacted or dropped. Do not stack anything on top of the assembly.

Prior to re-installation after any storage period, inspect the clamps and hardware for fastener preload and cleanliness. Each clamp should have a pair of rubber gaskets in the clamp saddle that mates to the fork slider, and should cycle open and closed freely.

CARE AND CLEANING

NOTE

Sunlight reflections off of the inside curvature of a windshield can, at certain times of the day, cause extreme heat build-up on motorcycle instruments. Exercise care in parking. Park facing the sun, place an opaque object over the instruments, or adjust the windshield to avoid reflections.

CAUTION

Polycarbonate windscreens/windshields require proper attention and care to maintain. Failure to maintain polycarbonate properly can result in damage to the windscreen/windshield. (00483d)

CAUTION

Do not use harsh chemicals including rain sheeting products on Harley-Davidson windshields. They can cause dulling or hazing. If you want to use a windshield protectant on your windshield, try Harley Glaze Polish and Sealant (00231a)

CAUTION

Do not use benzene, paint thinner, gasoline or any other type of harsh cleaner on the windshield. Doing so will damage the windshield surface. (00232a)

Do not clean Lexan® polycarbonate in hot sun or high temperature. Powdered, abrasive or alkaline cleanser will damage the windshield. Never scrape the windshield with a razor blade or other sharp instruments because permanent damage will result.

NOTES

Covering the windshield with a clean, wet cloth for about 15 minutes before washing will make dried bug removal easier.

Harley-Davidson Windshield Water Repellent Treatment Part Number 99841-01 is approved for use on Harley-Davidson Lexan® windshields.



SERVICE PARTS

is02414

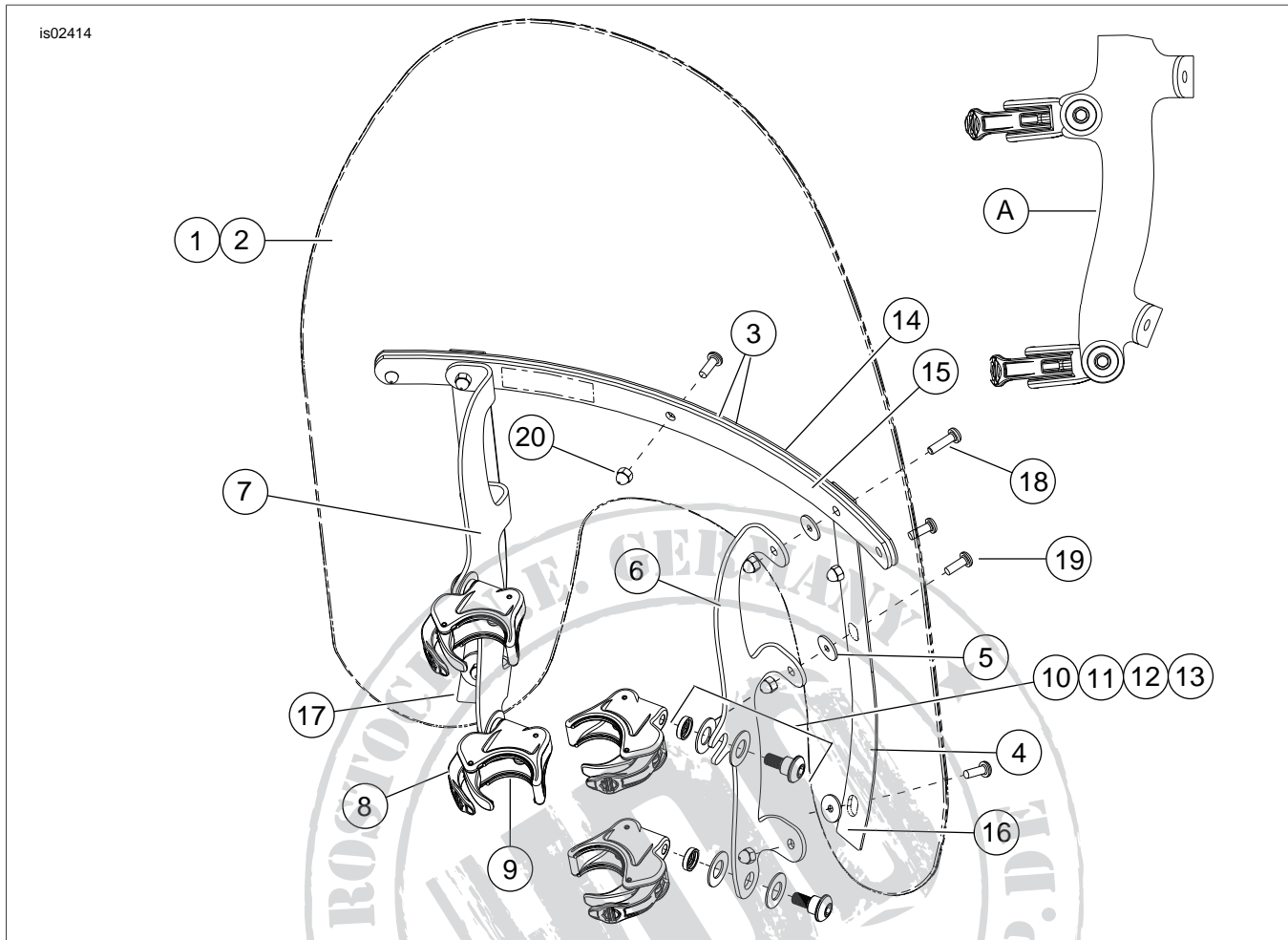

Figure 3. Service Parts: Compact Quick Release Windshield Kits

Table 2. Service Parts: Compact Quick Release Windshield Kits

Item	Description (Quantity)	Part Number	Item	Description (Quantity)	Part Number
1	Windshield service kit (includes items 2 through 5)		10	Hardware kit, windshield mount (4) (includes items 11 through 13)	58790-04
	Compact, standard height, clear	58061-96	11	Shoulder screw, button head	Not Sold
	Compact, standard height, smoked	58625-99	12	Spacer, cup washer	Not Sold
	Compact low profile, smoked	58103-96	13	Belleville washer (2)	Not Sold
2	Windshield	Not Sold	14	Brace, horizontal, outer	58051-78A
3	Tape, horizontal (2)	58052-78	15	Brace, horizontal, inner	58050-78A
4	Tape, vertical (2)	58417-77	16	Brace, vertical, right-hand	58406-75A
5	Washer, rubber, black (6)	58152-96	17	Brace, vertical, left-hand	58408-75A
6	FXD bracket, windshield mount, right	58782-06	18	Screw, button head, Torx, with lock patch, #12-24 x 13/16 inch (2)	2452
	FXDWG bracket, windshield mount, right	58786-06	19	Screw, button head, Torx, with lock patch, #12-24 x 5/8 inch (7)	2921
7	FXD bracket, windshield mount, left	58784-06	20	Acorn nut, #12-24 (chrome) (9)	7651
	FXDWG bracket, windshield mount, left	58787-06	A	Side view of clamps assembled to bracket	
8	Clamp assembly, tool-less release (4)	57192-05	NOTE: Appearance of windshield mount brackets may vary from illustration.		
9	Gasket (8, 2 per clamp)	57197-05			

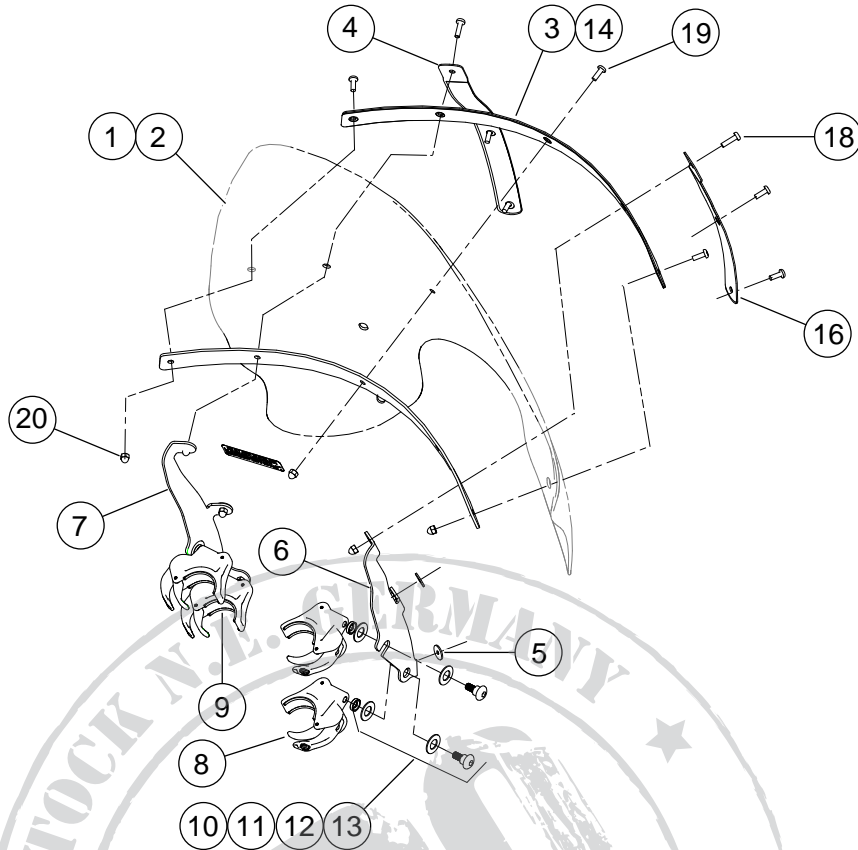

Figure 4. Service Parts: Touring Quick Release Windshield Kits

Table 3. Service Parts: Touring Quick Release Windshield Kits

Item	Description (Quantity)	Part Number	Item	Description (Quantity)	Part Number
1	Windshield service kit (includes items 2 through 5)		11	Shoulder screw, button head	Not Sold
	Touring, clear	57024-06	12	Spacer, cup washer	Not Sold
	Touring, smoked	57026-06	13	Belleville washer (2)	Not Sold
2	Windshield	Not Sold	14	Brace, horizontal, outer	58577-96
3	Tape, horizontal (2)	58582-96	15	Brace, horizontal, inner	58578-96
4	Tape, vertical (2)	57019-06	16	Brace, vertical, right-hand	57020-06
5	Washer, rubber, black (4)	58152-96	17	Brace, vertical, left-hand	57021-06
6	Bracket, windshield mount, right	57022-06	18	Screw, button head, Torx, with lock patch, #12-24 x 13/16 inch (2)	2452
7	Bracket, windshield mount, left	57023-06	19	Screw, button head, Torx, with lock patch, #12-24 x 5/8 inch (7)	2921
8	Clamp assembly, tool-less release (4)	57192-05	20	Acorn nut, #12-24 (chrome) (9)	7651
9	Gasket (8, 2 per clamp)	57197-05	NOTE: Appearance of windshield mount brackets may vary from illustration.		
10	Hardware kit, windshield mount (4) (includes items 11 through 13)	58790-04			

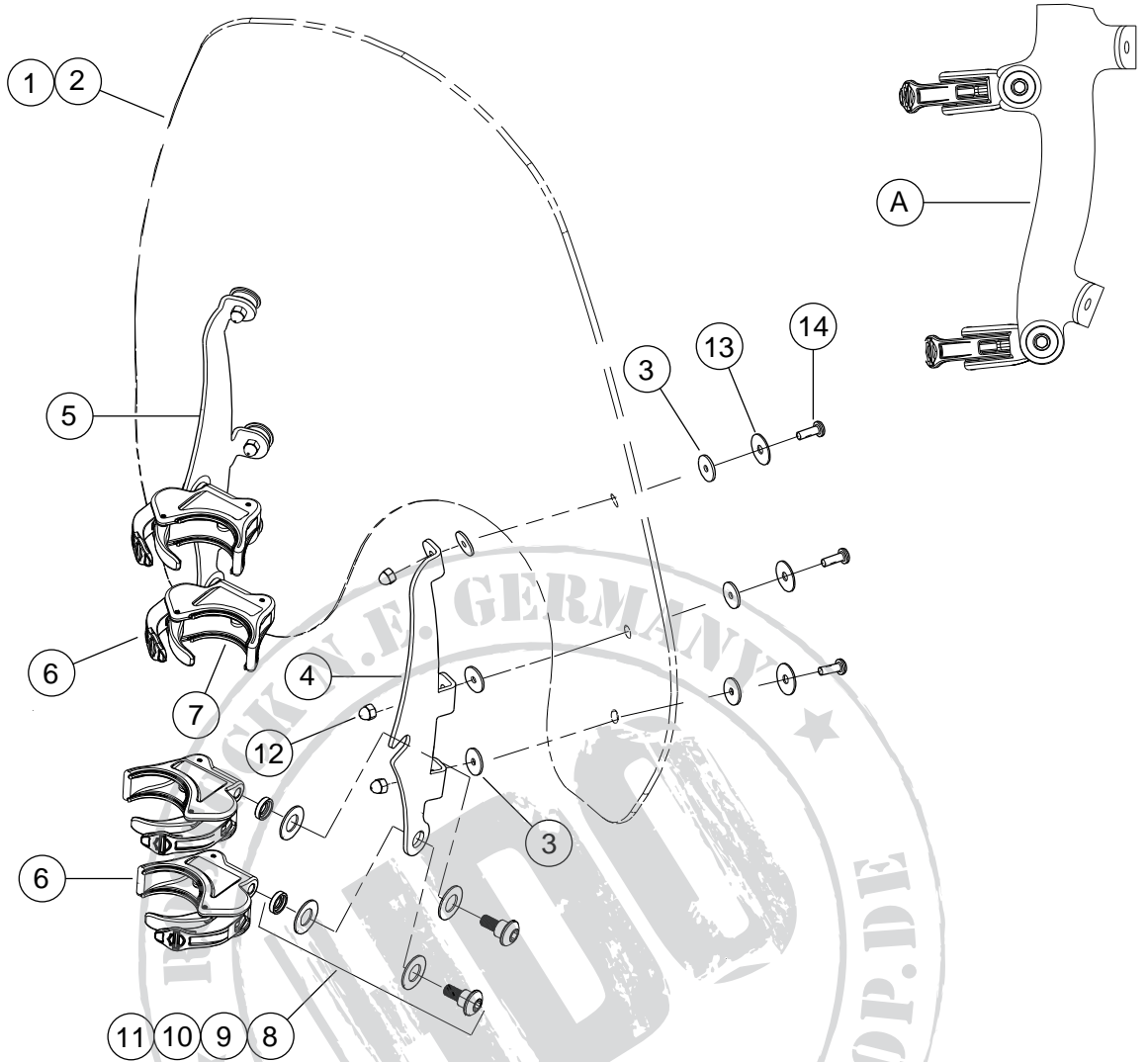

Figure 5. Service Parts: Super Sport Quick Release Windshield Kits

Table 4. Service Parts: Super Sport Quick Release Windshield Kits

Item	Description (Quantity)	Part Number	Item	Description (Quantity)	Part Number
1	Windshield service kit, Super Sport (includes items 2 through 3)	57302-06	8	Hardware kit, windshield mount (4) (includes Items 9 through 11)	58790-04
2	Windshield	Not Sold	9	Shoulder screw, button head	Not Sold
3	Washer, rubber, black (12)	58152-96	10	Spacer, cup washer	Not Sold
4	FXD bracket, windshield mount, right	57304-06	11	Belleville washer (2)	Not Sold
	FXDWG bracket, windshield mount, right	57306-06	12	Acorn nut, #12-24 (chrome) (6)	7651
5	FXD bracket, windshield mount, left	57305-06	13	Washer, stainless steel (6)	6914
	FXDWG bracket, windshield mount, left	57307-06	14	Screw (6)	2921
6	Clamp assembly, tool-less release (4)	57192-05	A	Side view of clamps assembled to bracket	
7	Gasket (8, 2 per clamp)	57197-05	Note: Appearance of windshield mount brackets may vary from illustration.		

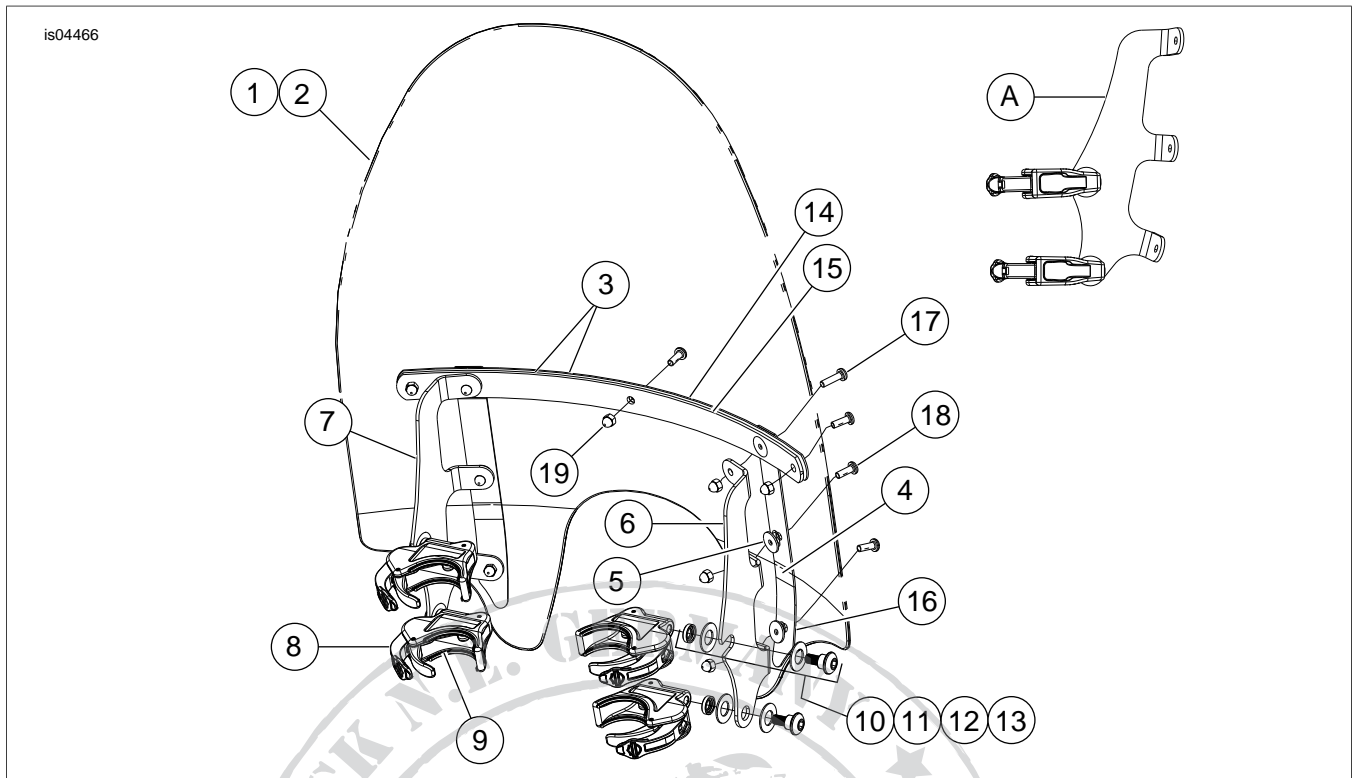

Figure 6. Service Parts: Quick Release Windshield Kit with cut-out for Auxiliary Lamps

Table 5. Service Parts: Quick Release Windshield Kit with cut-out for Auxiliary Lamps

Item	Description (Quantity)	Part Number	Item	Description (Quantity)	Part Number
1	Windshield service kit for FXD with Aux Lamp Cut Out (includes items 2 through 5)	58774-08	11	Shoulder screw, button head	Not Sold Separately
2	Windshield	Not Sold Separately	12	Spacer, cup washer	Not Sold Separately
3	Tape, horizontal (2)	58052-78	13	Belleville washer (2)	Not Sold Separately
4	Tape, vertical (2)	58415-08	14	Brace, horizontal, outer	58051-78A
5	Washer, rubber, black (6)	58152-96	15	Brace, horizontal, inner	58050-78A
6	FXD bracket, windshield mount, right	57602-08	16	Brace, vertical (2)	57603-08
7	FXD bracket, windshield mount, left	57601-08	17	Screw, button head, Torx, with lock patch, #12-24 x 13/16 inch (2)	2452
8	Clamp assembly, tool-less release (4)	57192-05	18	Screw, button head, Torx, with lock patch, #12-24 x 5/8 inch (7)	2921
9	Gasket (8, 2 per clamp)	57197-05	19	Acorn nut, #12-24 (chrome) (9)	7651
10	Hardware kit, windshield mount (4)(includes items 11 through 13)	58790-04			
A	Side view of clamps assembled to bracket.		Note: Appearance of windshield mount brackets may vary from illustration.		

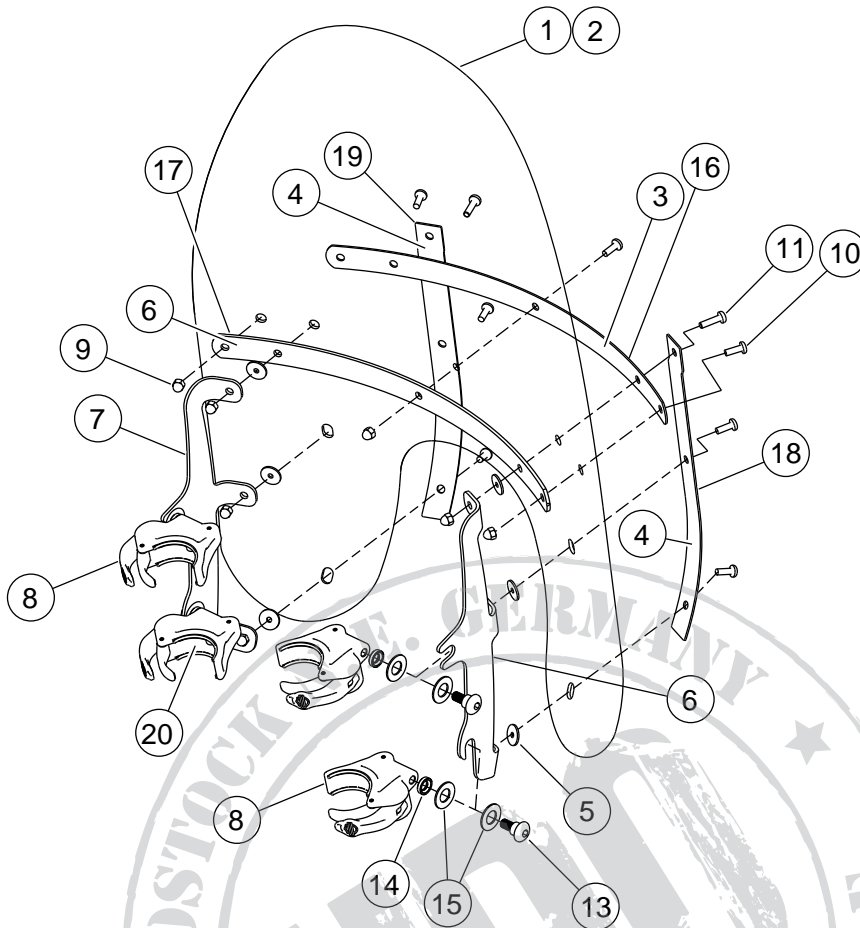

Figure 7. Service Parts: Quick Release Windshield Kits - FXDF

Table 6. Service Parts: Quick Release Windshield Kits - FXDF

Item	Description (Quantity)	Part Number	Item	Description (Quantity)	Part Number
1	Windshield, standard, clear, twin lamp	57344-08	11	Screw, button head, Torx, with lock patch, #12-24 x 13/16 inch (2)	2452
2	Windshield, low profile, smoke, twin lamp	57346-08	12	Hardware kit, windshield mount (4) (includes items 13 through 15)	58790-04
3	Tape, horizontal (2)	58052-78	13	• Shoulder screw, button head	Not Sold
4	Tape, vertical (2)	58417-77	14	• Spacer, cup washer	Not Sold
5	Washer, rubber, black (4)	58152-96	15	• Belleville washer (2)	Not Sold
6	Bracket, windshield mount, right, FXDF Bracket, windshield mount, black, right, FXDF	58775-08 58662-09	16	Brace, horizontal, outer Brace, horizontal, black, outer	58051-78A 58069-09
7	Bracket, windshield mount, left, FXDF Bracket, windshield mount, black, left, FXDF	58776-08 58667-09	17	Brace, horizontal, inner Brace, horizontal, black, inner	58050-78A 58068-09
8	Clamp assembly, tool-less release (4)	57192-05	18	Brace, vertical, right-hand Brace, vertical, black, right-hand	58406-75A 58045-09
9	Acorn nut, #12-24 (chrome) (9)	7651	19	Brace, vertical, left-hand Brace vertical, black, left-hand	58408-75A 58046-09
10	Screw, button head, Torx, with lock patch, #12-24 x 5/8 inch (7)	2921	20	Gasket, (8, 2 per clamp)	57197-05

Note: Appearance of windshield may vary from illustration.