



INSTRUCTIONS

-J04002

REV. 2006-10-16

ADJUSTABLE AIR DEFLECTOR KIT

GENERAL

Kit Number

57804-07

Models

For model fitment information, please see the P&A Retail Catalog or the Parts and Accessories section of www.harley-davidson.com (English only).

Kit Contents

See Figure 2 and Table 1.

INSTALLATION

Installing the Thumb Tabs

1. See Figure 2. Obtain the two air deflectors (1 and 2) and two thumb tabs (4) from the kit. Position one air deflector so the three hinge mounting Phillips screw heads at the bottom of the deflector are facing you.

NOTES

Ambient temperature should be **at least** 60° F (16° C) for proper adhesion of the thumb tab to the air deflector wing.

For easiest operation, mount the thumb tab in line with the hinges of the deflector wing, in the molded depression second from the top (see Figure 1).

The thumb tab should be mounted with the five ribs at the top.

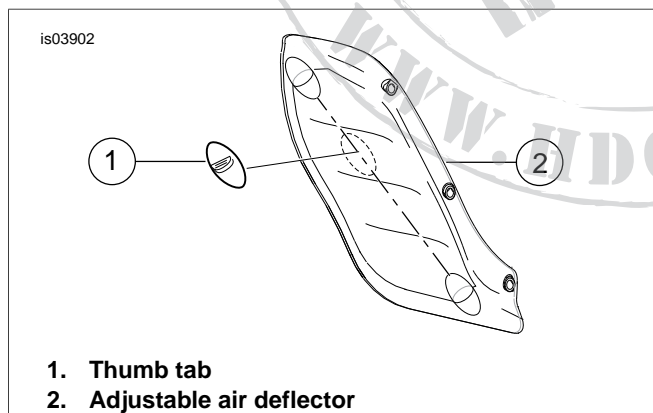

Figure 1. Install Thumb Tab (Left Side Shown)

2. Obtain the alcohol wipe (5) from the kit. Open the packet, and use the wipe to thoroughly clean the thumb tab mounting area of any dirt or grease.
3. Peel the liner from the adhesive backing of the thumb tab. Carefully position the tab to the air deflector, and press firmly into the position indicated in Figure 1. Hold the tab in position with steady pressure for five minutes to ensure proper adhesion.
4. Repeat Step 3 for the opposite air deflector.

Installing the Air Deflectors

5. See Figure 2. **Models with NO air deflectors installed:** Remove and discard the six hole plugs (A) from the right and left edges of the inner fairing assembly.

Models WITH air deflectors currently installed: Remove and discard the six screws that retain the right and left air deflectors. Remove and discard the deflectors.

6. Select a right-side (1) or left-side (2) air deflector, and three thumb screws (3) from the kit. Determine the correct side by holding the mounting-hole side of the deflector against the fairing.

The thumb tab is accessible from the rider position. The three hinge mounting screws will be visible only from the rider position, and not from the front of the vehicle.

7. Place the deflector against the inner fairing, lining up the holes. Insert the screws through the deflector holes and into the fairing air deflector holes. Tighten the screws snugly, but **DO NOT over-tighten**.
8. Repeat Steps 6 and 7 for the remaining deflector.

AIR DEFLECTOR ADJUSTMENT

WARNING

Adjust air deflectors before riding. Distractions can lead to loss of control, resulting in death or serious injury. (00525b)

1. Push the thumb tab downward toward the ground to free the wing from the locking mechanism. Rotate the wing into any of four positions (fully open to fully closed).
2. Release the thumb tab. The spring in the lower hinge mount will automatically push the wing into the nearest position and lock it in place.

SERVICE PARTS

is03757

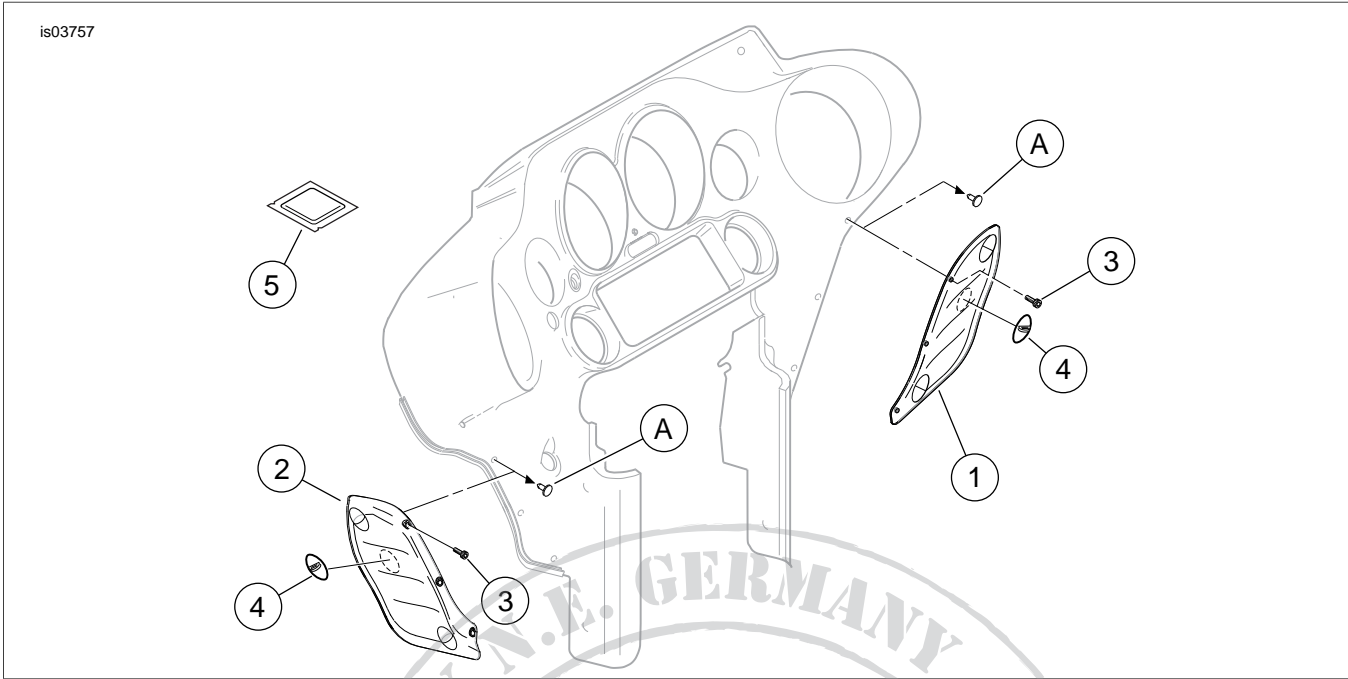

Figure 2. Service Parts, Adjustable Air Deflector Kit

Table 1. Service Parts Table

Item	Description (Quantity)	Part Number
1	Air deflector, adjustable (right side)	Not sold separately
2	Air deflector, adjustable (left side)	Not sold separately
3	Thumb screw, knurled, #10-24 x 3/4 in. (6)	Not sold separately
4	Tab, thumb (2)	Not sold separately
5	Alcohol wipe	Not sold separately
Item mentioned in text, but not included in kit:		
A	Original equipment hole plug (6)	