



INSTRUCTIONS

-J05280

REV. 2011-04-08

1.00 INCH (25.4 MM) DIAMETER HANDLEBAR KITS

GENERAL

Kit Numbers

57474-11, 57485-11

Models

For model fitment information, see the P&A retail catalog or the Parts and Accessories section of www.harley-davidson.com (English only).

Additional Parts or Accessories Required

Separate purchase of additional parts or accessories is required for proper installation of this handlebar kit on this model motorcycle. See the P&A retail catalog or the Parts and Accessories section of www.harley-davidson.com (English only) for a list of required parts or accessories for this model.

Separate purchase of a Twist Grip Sensor Kit (H-D Part No. 32310-08) is required for all models.

WARNING

Replace brake line gaskets. Re-using original gaskets can cause brake failure and loss of vehicle control, which could result in death or serious injury. (00318a)

Motorcycles equipped with a **glued** left side hand grip will also require a new grip, sold separately. Refer to the parts catalog for replacement OE hand grips.

FLHX Models require separate purchase of handlebar-mounted mirrors. If fairing-mounted mirrors are to be removed, separate purchase of two small (H-D Part No. 755) and two large (H-D Part No. 732) hole plugs is recommended.

Ask a Harley-Davidson dealer about the selection of Genuine Motor Accessory hand grips and handlebar-mounted mirrors (FLHX Models) that are available.

Tools and Supplies Required

Loctite® 243 Threadlocker and Sealant - Blue is required for proper installation of this kit.

Fresh, uncontaminated DOT 4 brake fluid from a sealed container will be needed.

A long shank ball-end socket (Snap-on® FABL6E or equivalent) will aid in the removal and installation of the radio or storage box.

WARNING

The rider's safety depends upon the correct installation of this kit. Use the appropriate service manual procedures. If the procedure is not within your capabilities or you do not have the correct tools, have a Harley-Davidson dealer perform the installation. Improper installation of this kit could result in death or serious injury. (00333a)

-J05280

NOTE

This instruction sheet refers to service manual information. A service manual for this year/model motorcycle is required for this installation and is available from a Harley-Davidson dealer.

Kit Contents

See Figure 4 and Table 1.

REMOVAL

WARNING

To prevent accidental vehicle start-up, which could cause death or serious injury, remove main fuse before proceeding. (00251b)

1. Refer to the service manual and follow the instructions to remove the main fuse.
2. Remove the outer fairing. See the service manual.
3. Remove the fairing cap. See the service manual.
4. **FLHX Models:** Handlebar-mounted mirrors (purchased separately) are required for proper installation of this handlebar. Removal of the inner fairing may be required, refer to the service manual.

If fairing-mounted mirrors are being removed: Install the two small black plugs and large black plugs (purchased separately) to plug the fairing mirror holes.

CAUTION

Direct contact of D.O.T. 4 brake fluid with eyes can cause irritation. Avoid eye contact. In case of eye contact flush with large amounts of water and get medical attention. Swallowing large amounts of D.O.T. 4 brake fluid can cause digestive discomfort. If swallowed, obtain medical attention. Use in well ventilated area. KEEP OUT OF REACH OF CHILDREN. (00240a)

NOTICE

D.O.T. 4 brake fluid will damage painted and body panel surfaces it comes in contact with. Always use caution and protect surfaces from spills whenever brake work is performed. Failure to comply can result in cosmetic damage. (00239b)

NOTE

*Immediately wipe up any brake fluid spillage with a clean, **dry**, soft cloth. Follow up by thoroughly wiping the affected area with a clean, **damp**, soft cloth (small spills) or washing with a large quantity of soapy water (large spills).*

Cover nearby motorcycle surfaces with an H-D Service Cover or polyethylene protective sheet to help protect against damage to the finish caused by spillage or splash of DOT 4 brake fluid.

5. Drain the brake fluid from the front brake reservoir and lines per the instructions in the service manual.

NOTE

Cover the front fender and the fuel tank with an H-D Service Cover or clean shop towels to prevent scratching.

6. **Models with Radio:** Remove the radio. See the service manual.

Models without Radio: Remove the storage box. See the service manual.

- a. The four socket head screws fastening the radio or storage box to the left and right radio support brackets can be accessed through the oblong holes in the fairing brackets. Use a long shank ball-end socket to remove the screws.
- b. Pull the radio or storage box forward to remove it from the opening in the inner fairing.

NOTICE

Remove brake line components carefully. Damage to seating surfaces can cause leakage. (00320a)

7. Remove and retain the button head screw on the underside of the fork stem and bracket assembly that holds the brake line manifold tee.
8. Note the front brake line routing and the orientation of the banjo fittings. Disconnect the brake line from the front brake calipers and the front brake master cylinder assembly.
Save the banjo bolts, but **discard** the two gaskets found at each banjo fitting. See the service manual.
9. Remove the front brake line assembly.

NOTE

Ask a Harley-Davidson dealer about the selection of Genuine Motor Accessory Custom Braided Clutch Cables and Brake Lines that are available.

10. Remove the front brake master cylinder and clutch lever assemblies from the handlebar.
11. Disconnect the clutch cable from the clutch lever. See the service manual.

Follow the instructions in the service manual to disconnect the clutch cable from the side cover and remove the cable from the vehicle.

NOTE

Note the harness routing and location of connector clips and cable straps before disconnecting and removing wiring inside the fairing.

12. Disconnect the handlebar control wiring from the gray sixteen-way and black twelve-way main harness connectors inside the fairing. Refer to the service manual.
13. Remove and discard the cable straps that secure both switch harnesses to the handlebar.
14. Remove the right side switch housing assembly and wire harness. Refer to the service manual.

15. Remove the left side switch housing assembly and wire harness. Refer to the service manual.
16. **If the left side hand grip is not glued to the handlebar:** Remove the end cap from the hand grip (if equipped). Remove the hand grip and set it aside for installation onto the new handlebar.
17. Remove the end cap from the right hand grip (if equipped). Remove the hand grip from the handlebar.

NOTES

The twist grip sensor in the right side of the handlebar has a seal cap that protects internal electrodes from dirt and moisture, and also serves as a throttle grip retainer.

To remove the grip, a slight tug may be necessary to release the index pins in the grip from the receptacle in the seal cap.

If the throttle grip is being replaced: Discard the throttle grip and proceed to Step 16.

If the throttle grip is not being replaced: After removing the grip, note if the seal cap is attached to the end of the twist grip sensor.

- If the seal cap is attached to the sensor, proceed to Step 16.
 - If the seal cap is still fastened to the index pins **inside** the throttle grip, use a stiff piece of mechanic's wire to capture the seal cap and pull it free of the index pins.
18. Remove the OE twist grip sensor and discard. Refer to the service manual.

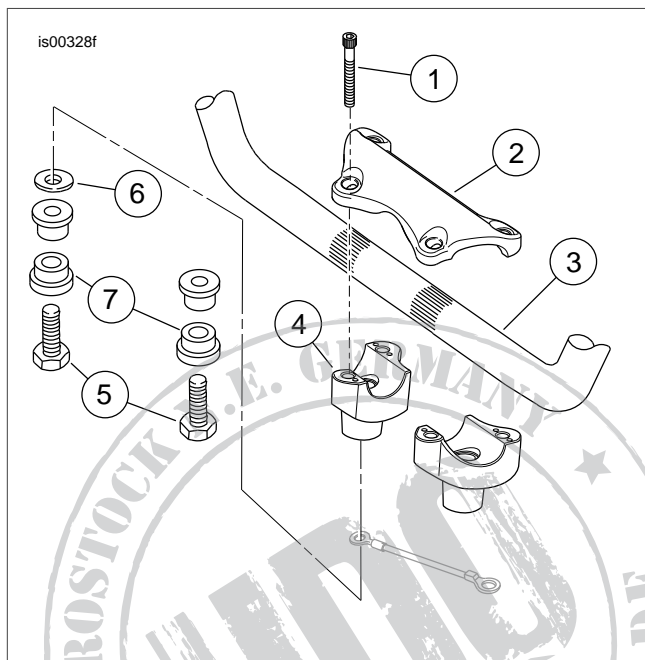

Figure 1. Handle Clamp and Risers

19. See Figure 1. Remove the screws (1) that fasten the handlebar upper clamp (2) to the risers (4), and remove the clamp. Remove the handlebar (3).

NOTE

Do not remove the wires from the Molex handlebar switch connector **pin housings** inside the fairing.

20. Remove riser attachments screws (5). Remove rubber bushings (7), and washer (6) (if present). Discard cup washers and spacers.
21. Apply a small amount of Loctite 243 (blue) to the riser screws. Replace rubber bushings with aluminum bushings from the kit. Install riser screws and tighten until snug. The screws will be tightened to specification later in the procedure.
22. Note the wire colors and positions in each cavity of the socket housings leading from the switches. Refer to the wiring diagram and the service manual. Remove the wires (with socket terminals) from the socket housings.
23. **For internal handlebar switch wiring:** Use tape to wrap the wire terminal ends from each source to make separate leaders. Wrap each leader tight enough to enter the wire entrance hole at the handlebar switch location and pass easily through the **new** handlebar.

INSTALLATION

Internal Handlebar Wiring

1. Route the wires through the handlebars following the instructions in the service manual.

NOTES

The twist grip sensor **MUST** be replaced with a **new** sensor (H-D Part No. 32310-08), sold separately.

Reverse switch wiring for Trike models must be wired externally.

2. Obtain the Twist Grip Sensor Kit (purchased separately). Use tape to wrap the wire terminals on the ends of the twist grip sensor wires to make a single leader. Wrap the leader tight enough to pass easily through the new handlebar.
3. Tie the end of the string from the right side handlebar end hole to the twist grip sensor wire bundle.
4. Tie the end of the string from the right side switch wire hole to the right side switch wire bundle.
5. Apply a light coat of liquid soap, window cleaner or all-purpose lubricant to the right side switch and twist grip sensor wire bundles.

WARNING

Wiring in the switch housings must be routed exactly as shown. Pinch points in the switch housings can short-circuit or sever wires, which could cause loss of control resulting in death or serious injury. (00415b)

6. Gently feed the twist grip sensor wire bundle into the right side handlebar end.
See Figure 2. Route the right side switch wire bundle through the switch housing as shown. Gently feed the wire bundle into the right side switch wire hole.
Pull the bundles down through the new handlebar and toward the center of the bar, while fitting the index tabs on the twist grip sensor into the slots on the end of the handlebar. One index tab and slot are smaller than the other to aid in proper assembly.

WARNING

Carefully pull the wires through hole in handlebar to prevent stripping the wires. Stripped wires can cause short circuits and damage vehicle electrical components, which could cause loss of vehicle control resulting in death or serious injury. (00418b)

7. Pull the taped ends of the wire bundles through the wire-exit hole at the bottom center of the handlebar.
8. Tie the end of the string from the left side switch wire hole to the left side switch wire bundle.
9. If necessary, apply a light coat of liquid soap, window cleaner or all-purpose lubricant to the left side switch wire bundle.
10. Route the left side switch wire bundle through the switch housing as shown in Figure 2 for the right side wiring. Gently feed the wire bundle into the left side switch wire hole.
Pull the bundle down through the new handlebar and toward the center of the bar.
11. Loosely fasten the brake lever and clutch lever clamps to the new handlebar.
12. Loosely fasten the handlebar switch housings to the new handlebar.
13. Remove the tape from the ends of the wire bundles.
14. Check for electrical continuity between the handlebar and each wire in the wire bundles. Continuity would indicate a short circuit, which would require examination of the wires and routing in the switch housing.
Proceed to **Handlebar Installation**.

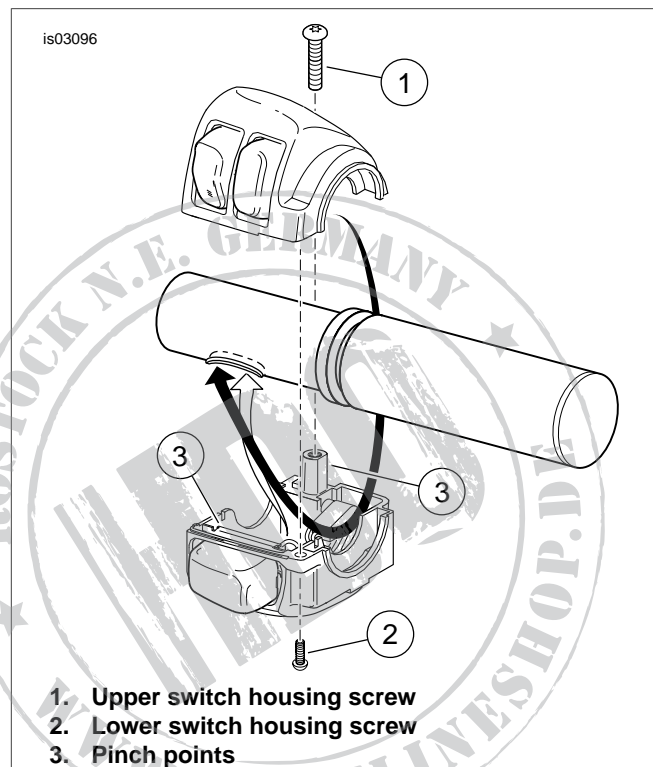

Figure 2. Switch Housing Wire Routing (Right Side Housing Shown)

Handlebar Installation

- Center the new handlebar on the risers. Verify that the knurled handlebar areas exposed on the outboard side of each riser are equal.
- Position the original handlebar upper clamp and loosely install with the clamp screws saved earlier.
- Rotate the handlebar forward until the handlebar contacts the inner fairing. Rotate handlebar back until there is a gap 1/8" to 1/4" away from the inner fairing.

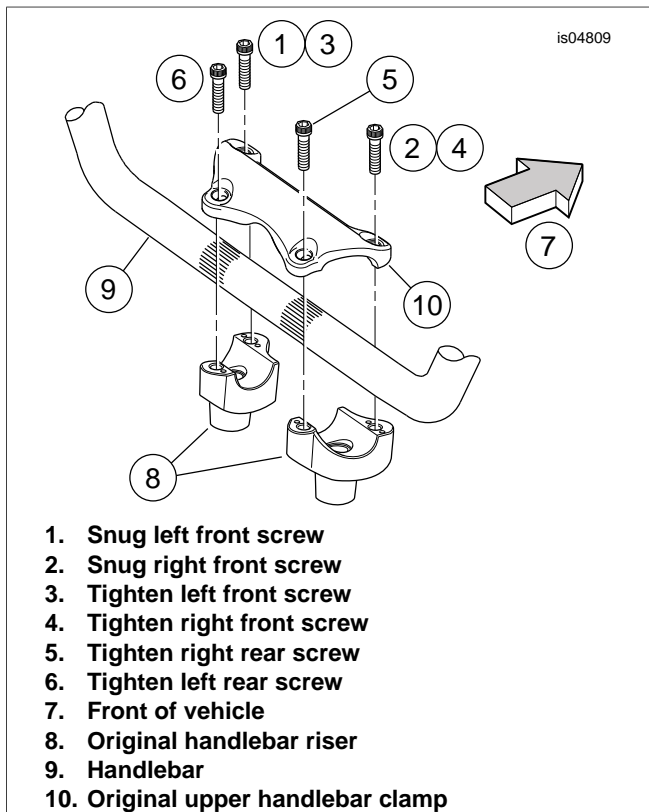

Figure 3. Handlebar Clamp Screw Tightening Sequence

NOTE

The handlebar upper clamp is designed to leave a gap between the clamp and riser to the rear of the handlebar when installed.

- See Figure 3. Snug, but do not fully-tighten, only the front two upper clamp screws in the following sequence:
 - First, snug the left front screw (1).
 - Then, snug the right front screw (2).
- Refer to the notes made during the removal steps, and the wiring diagram and the service manual. Insert each socket terminal from the left side switch wire bundle into the correct cavity of the gray socket housing removed earlier.
- Insert each socket terminal from the right side switch wire bundle into the correct cavity of the black socket housing removed earlier.

NOTE

It may be necessary to disconnect the wire harness housings from the fairing supports. After connecting the pin and socket housings tie wrap the wiring to secure it inside the fairing.

- Connect the gray handlebar switch wire socket housing to the gray pin housing inside the nacelle. Connect the black handlebar switch wire socket housing to the black pin housing inside the fairing.
- Obtain the PVC tubing and the six-way black Molex pin housing from the Twist Grip Sensor Kit (purchased separately). Install the tubing over ALL of the wires coming from the twist grip sensor.
- Insert each pin terminal from the twist grip sensor into the correct cavity of the pin housing as follows:

From the **yellow** conduit,

- Black wire to cavity 1
- White wire to cavity 2
- Red wire to cavity 3

From the **black** conduit,

- Black wire to cavity 4
- White wire to cavity 5
- Red wire to cavity 6

Position the PVC tubing installed in Step 7 in the area of the radio or storage box. The tubing will be moved to the proper location at final assembly.

- Connect the six-way black Molex pin housing from the twist grip sensor to the black six-way socket housing inside the fairing.

NOTICE

Improperly aligned handlebars or components can contact the fuel tank when turned to the left or right. Contact with the fuel tank can cause cosmetic damage. (00372b)

- Slowly turn the front wheel to the full-right fork stop and then the full-left fork stop to be sure the handlebar does not contact the fuel tank. If contact occurs and the handlebars are properly centered, raise the handlebar angle as necessary until proper clearance is attained.
- Tighten the riser screws to 30-40 ft-lbs (41-52 Nm).

NOTE

The upper handlebar clamp screws **MUST** be final-tightened in the following sequence to make sure proper clamping is achieved.

13. See Figure 3. Tighten the upper handlebar clamp screws as follows:

- a. Tighten the left side front screw (1) until the left side of the handlebar clamp makes contact with the front of the left side handlebar riser.
- b. Tighten the right side front screw (2) until the right side of the handlebar clamp makes contact with the front of the right side handlebar riser.
- c. Tighten the left side front screw (3) to 16-20 ft-lbs (21.7-27.1 Nm).
- d. Tighten the right side front screw (4) to 16-20 ft-lbs (21.7-27.1 Nm).
- e. Tighten the right side rear screw (5) to 16-20 ft-lbs (21.7-27.1 Nm).
- f. Tighten the left side rear screw (6) to 16-20 ft-lbs (21.7-27.1 Nm).

NOTE

There will be a slight gap between the upper clamps and the risers toward the rear of the handlebar after tightening.

14. Install a new (purchased separately) or original handlebar grip on the left end of the new handlebar following the handlebar grip instruction sheet or the service manual.
15. Adjust the positions of the switch housing and the clutch lever assembly on the handlebar for rider comfort.
16. Tighten first the top, then the bottom clutch-lever clamp screws to 72-108 **in-lbs** (8.1-12.2 Nm).
17. Tighten first the lower, then the upper **switch housing** screws to 35-45 **in-lbs** (4.0-5.1 Nm).
18. Install the new (purchased separately) or original right grip/throttle sleeve. Refer to the service manual.
19. Adjust the position of the switch housing and the brake lever assembly on the handlebar for rider comfort. The brake master cylinder must be level.

NOTE

*Tighten the top **brake lever clamp** screw before tightening the bottom screw.*

20. Tighten first the top, then the bottom brake lever clamp screws to 72-108 **in-lbs** (8.1-12.2 Nm).

NOTE

Tighten the lower switch housing screw before tightening the upper screw. This will leave any gap in the switch housing at the front for best appearance.

21. Tighten first the lower, then the upper switch housing screws to 35-45 **in-lbs** (4.0-5.1 Nm).
22. Verify that the right grip/throttle sleeve rotates and returns freely and does not bind on the handlebar or switch housing.

FINAL ASSEMBLY

WARNING

Replace brake line gaskets. Re-using original gaskets can cause brake failure and loss of vehicle control, which could result in death or serious injury. (00318a)

NOTICE

Avoid leakage. Be sure gaskets, banjo bolt(s), brake line and caliper bore are clean and undamaged before assembly. (00321a)

1. Carefully inspect the new (sold separately) brake line for damage or defects, and replace if damaged. Install following the instructions included with the brake lines.
2. Bleed the brakes. See the service manual.
3. Install the **new** clutch cable (sold separately) following the instructions included with the clutch cable kit.
4. **Models with Radio:** Install the radio. See the service manual.
Models without Radio: Install the storage box. See the service manual.
5. Position the PVC tubing on the twist grip sensor wires (previously installed) to prevent chafing of the twist grip sensor wires against the heat sink fins on the radio (if equipped) and the sharp edges of the radio or storage box mounting bracket inside the fairing.
6. Install the fairing cap. See the service manual.
7. Install the outer fairing. See the service manual.
8. **FLHX Models:** Install handlebar-mounted mirrors following the instructions in the service manual.

SAFETY CHECK

WARNING

Be sure that steering is smooth and free without interference. Interference with steering could result in loss of vehicle control and death or serious injury. (00371a)

- Be sure wires, clutch cables and brake lines do not pull tight when handlebars are turned fully to the left or right fork stops.
1. Verify that the ignition key switch is turned to the OFF position.
Install the main fuse. Refer to the service manual.

WARNING

Be sure that all lights and switches operate properly before operating motorcycle. Low visibility of rider can result in death or serious injury. (00316a)

2. Turn the ignition key switch to IGNITION, but do not start the motorcycle. Test each handlebar switch for proper operation.
3. Turn the handlebar to the left and right steering stops, testing the handlebar control functions at each stop.
4. Apply the front brake hand lever to test operation of the brake lamp.

⚠ WARNING

Before starting engine, be sure throttle control will snap back to idle position when released. A throttle control that prevents engine from automatically returning to idle can lead to loss of control, which could result in death or serious injury. (00390a)

⚠ WARNING

After repairing the brake system, test brakes at low speed. If brakes are not operating properly, testing at high speeds can cause loss of control, which could result in death or serious injury. (00289a)

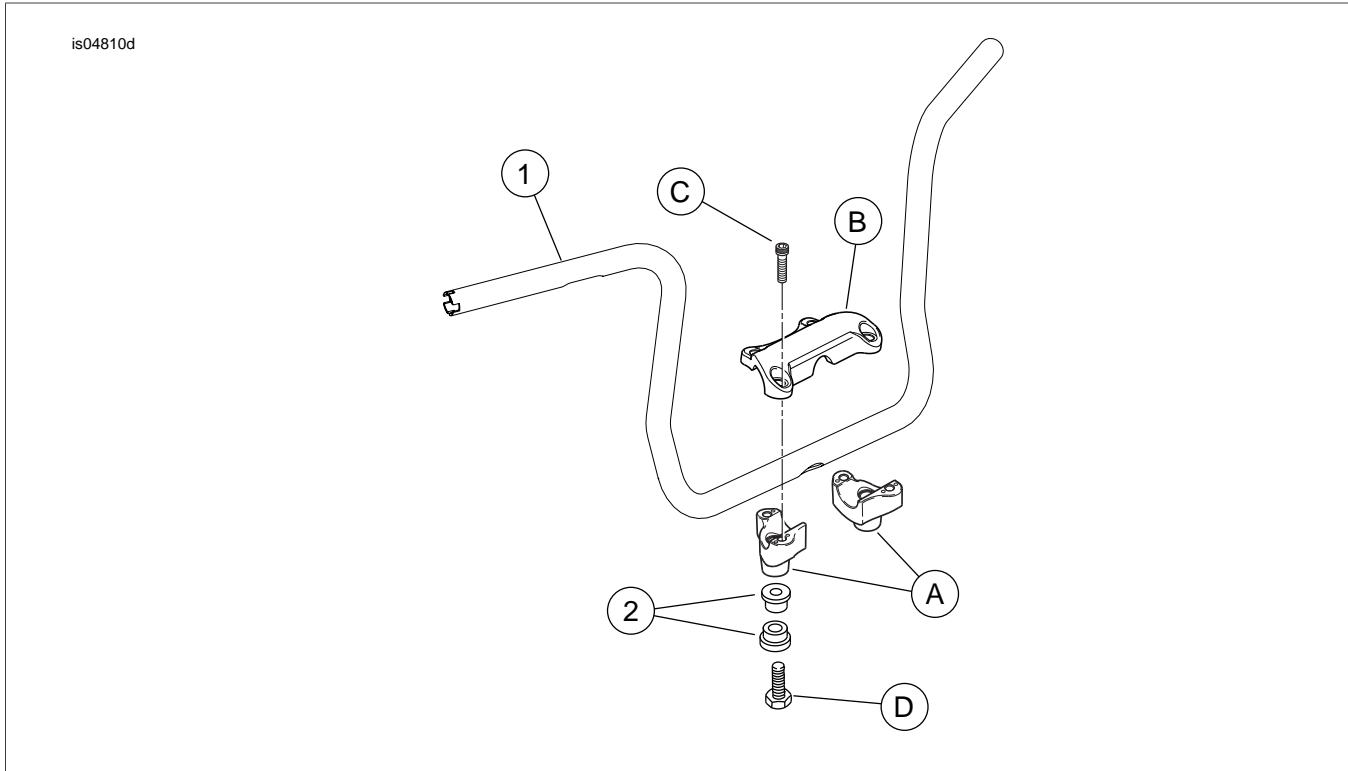
SERVICE PARTS

Figure 4. Service Parts: Handlebar Kits

Table 1. Service Parts, Handlebar Kits

Kit	Item	Description (Quantity)	Part Number
Kit 57474-11	1	Handlebar	Not sold separately
Kit 57485-11	2	Handlebar bushing (4)	Not Sold Separately
Items mentioned in text, but not included in kit:			
	A	Original equipment handlebar riser (2)	
	B	Original equipment upper handlebar clamp	
	C	Original equipment handlebar clamp screw (4)	
	D	Screw (2)	
Kit 32310-08 - Twist Grip Sensor Kit (Purchased Separately)			
The Heated Hand Grip items below are not used with these Handlebar Kits, and can be discarded:			
		Socket housing, two-way	
		Secondary lock, two-way socket housing	
		Seal pin (plug) (2)	
		Pin housing, two-way	
		Secondary lock, two-way pin housing	