



INSTRUCTIONS

-J06023

2014-05-18

FLRT WINDSHIELD KITS

GENERAL

Kit Number

57400273, 57400274

Models

For model fitment information, see the P&A retail catalog or the Parts and Accessories section of www.harley-davidson.com (English only).

Kit Contents

See Figure 1 and Table 1.

INSTALLATION

1. Lower the windshield into position. Carefully insert the side brackets on the lower grommets. Verify that the notches on each bracket are firmly seated on a rubber grommet.
2. Gently push the top of the windshield toward the rear until the upper notches fully engage the upper grommets.

▲ WARNING

Improper installation of accessories or loading of cargo can affect motorcycle stability and handling, which could result in death or serious injury. (00455b)

▲ WARNING

Failure to provide adequate clearance between stationary and moving parts can cause loss of control, which could result in death or serious injury. (00378a)

NOTE

Inspect windshield upon completion of installation. Verify that windshield mounting does not restrict full left or full right movement of front fork assembly. If restriction does occur, adjust windshield as needed until proper clearance is obtained. Have experienced Harley-Davidson service personnel correct any problems before riding with this accessory installed.

NOTE

Check mounting hardware periodically. Never ride with loose mounts. A loose mounting causes extra stress on all other

mounts, as well as the windshield itself. This causes premature failure of components.

CARE AND CLEANING

NOTE

NOTICE

Use only Harley-Davidson recommended products on Harley-Davidson windshields. Do not use harsh chemicals or rain sheeting products, which can cause windshield surface damage, such as dulling or hazing. (00231c)

NOTICE

Polycarbonate windscreens/windshields require proper attention and care to maintain. Failure to maintain polycarbonate properly can result in damage to the windscreen/windshield. (00483d)

- Do not use benzene, paint thinner, gasoline or any other type of harsh cleaner on the windscreen/windshield. Doing so damages the surface.
- Do not clean in hot sun or high temperature.
- Powdered, abrasive or alkaline cleanser damages the windshield. Never scrape the windshield with a razor blade or other sharp instruments. This causes permanent damage.
- Sunlight reflections off the inside curvature of a windshield can cause extreme heat build-up on motorcycle instruments. Exercise care in parking. Park facing the sun, place an opaque object over the instruments, or adjust the windshield to avoid reflections.

NOTE

Covering the windshield with a clean, wet cloth for about 15 minutes before washing makes dried bug removal easier.

Harley-Davidson Windshield Water Repellent Treatment (Part No. 99841-01) is approved for use on Harley-Davidson polycarbonate windshields.

SERVICE PARTS

NOTE

Typical windshield shown. Actual windshield varies.



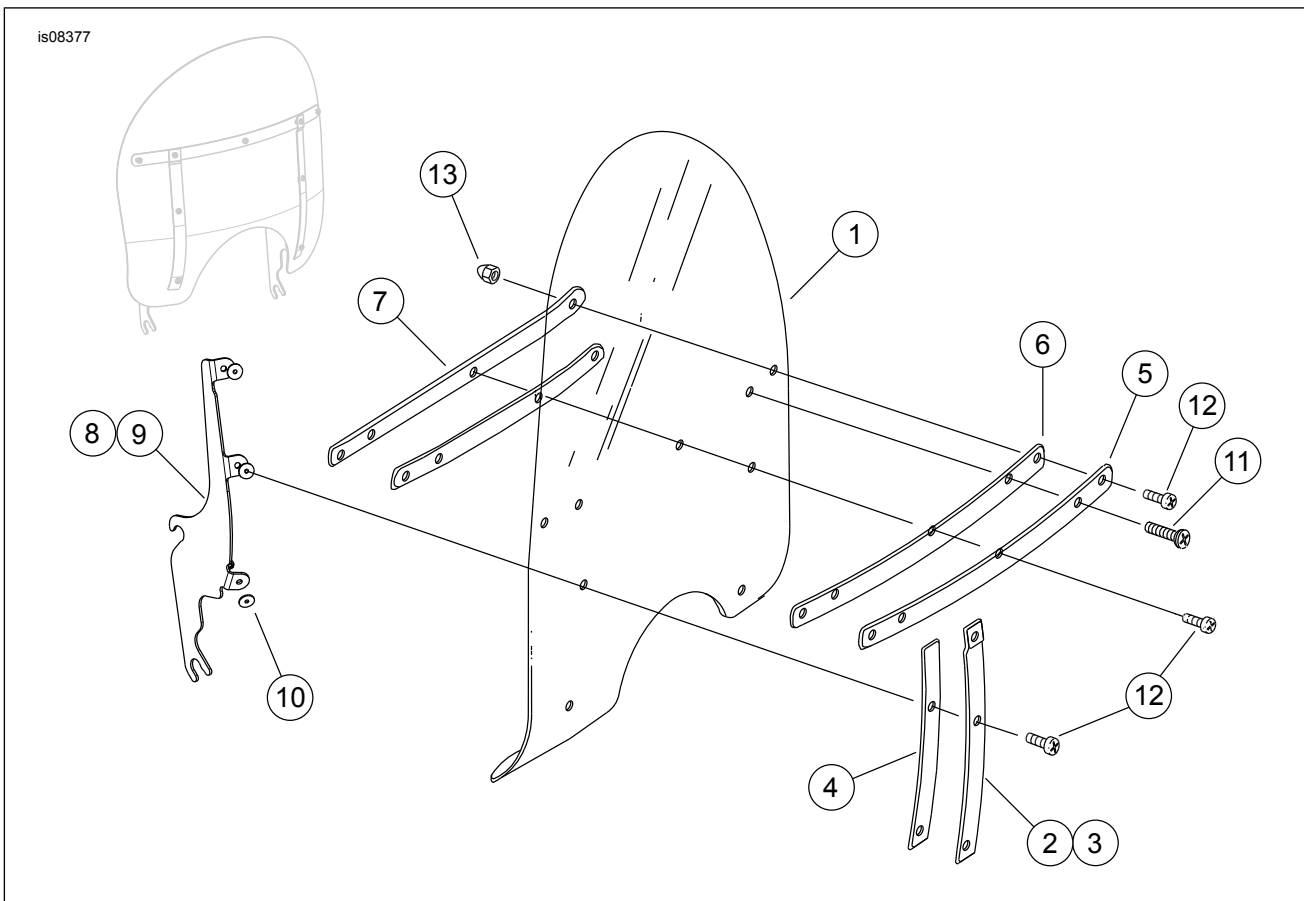

Figure 1. Service Parts

Table 1. Service Parts Table

Item	Description (Quantity)	Part Number
1	Windshield, 16 in	57400277
	Windshield, 20 in	57400278
2	Outer vertical brace, RH	58406-75A
3	Outer vertical brace, LH	58408-75A
4	Outer vertical brace tape (2)	58417-77
5	Outer horizontal brace	58428-94
6	Horizontal brace tape (2)	58416-77A
7	Inner horizontal brace	53431-94
8	Bracket, RH	57400275
9	Bracket, LH	57400276
10	Washer, windshield mounting (6)	58416-77A
11	Panhead Torx screws (2)	2452
12	Panhead Torx screws (7)	2921
13	Acorn nuts (9)	7651