



INSTRUCTIONS

-J05617

2012-07-11

FLST (WITH FOG/PASSING LAMPS) VENTED DETACHABLE WINDSHIELD

GENERAL

Kit Number

57400159

Models

For model fitment information, see the P&A retail catalog or the Parts and Accessories section of www.harley-davidson.com (English only).

Additional Parts Required

NOTE

A service manual for your model motorcycle is available from a Harley-Davidson Dealer.

Kit Contents

See Figure 1 and Table 1, Figure 2 and Table 2.

INSTALLATION

▲ WARNING

The rider's safety depends upon the correct installation of this kit. If the procedure is not within your capabilities or you do not have the correct tools, have a Harley-Davidson dealer perform the installation. Improper installation of this kit could result in death or serious injury. (00308a)

NOTE

Place shop rags on the headlamp and front of the fuel tank to prevent scratches to headlamp and fuel tank. Be sure the windshield assembly does not contact chrome or painted parts. Contact will cause scratches to chrome or painted parts.

Spacers on the topmost screws will fall free when the screws are removed. Take care that the spacers do not strike the fuel tank or fender, damaging the finish.

1. Remove the stock windshield, if so equipped. See Removing the Windshield. Discard the windshield.

NOTE

Keep front wheel straight to prevent brackets from scratching fuel tank.

2. Inspect the windshield mounting bushings (if equipped). If worn proceed to step 3, otherwise proceed to step 8.
3. Figure 2 and Table 2. Remove and discard the original bottom fog/passing lamp bracket screw (4) and washer (1).

4. Place a new flat washer (1), bushing (2) and flat washer (1) on a 1-3/8 inch long screw (4) from the kit. Thread the screw through the lower hole in the fog/ passing lamp bracket and decorative fork cover, and into the triple clamp. Tighten the screw to 10.8 N·m (8 ft-lbs).
5. Repeat Step 4 on the opposite side of the motorcycle.
6. Place a flat washer (1), bushing (2), and flat washer (1), on a screw (3) from the kit. Place the screw through the top hole of the fog/passing lamp bracket and through the spacer. Tighten screws to 10.8 N·m (8 ft-lbs).
7. Repeat Step 6 on the opposite side of the vehicle.
8. See Installing the Windshield.

▲ WARNING

Improper installation of accessories or loading of cargo can affect motorcycle stability and handling, which could result in death or serious injury. (00455b)

▲ WARNING

Failure to provide adequate clearance between stationary and moving parts can cause loss of control, which could result in death or serious injury. (00378a)

NOTE

Inspect windshield upon completion of installation. Be sure windshield mounting does not restrict full left or full right movement of front fork assembly. If restriction does occur, adjust windshield as needed until proper clearance is obtained. Have experienced Harley-Davidson service personnel correct any problems before riding with this accessory installed.

NOTE

Check mounting hardware periodically. Never ride with loose mounts. A loose mounting causes extra stress on all other mounts, as well as the windshield itself, and could result in premature failure of components.

REMOVING THE WINDSHIELD

1. Use a finger to raise the wireform latch springs on each side of the windshield.
2. Standing at the front of the vehicle, gently pull the top of the windshield until the upper notches on the side brackets are free of the upper bushings.
3. Carefully raise the windshield until the lower notches in the side brackets are free of the lower bushings.
4. Remove windshield from vehicle.



INSTALLING THE WINDSHIELD

1. Lower the windshield into position until the lower bracket notches are seated on the lower bushings.
2. Standing at the front of the vehicle, gently push the top of the windshield toward the rear until the upper notches fully engage the upper bushings.
3. Push down on the wireform latch springs (1) so that they overhang the rubber bushings. If some adjustment is necessary, loosen the retaining bolts and rotate the latch springs into the proper position.

CARE AND CLEANING

NOTE

Sunlight reflections off of the inside curvature of a windshield can, at certain times of the day, cause extreme heat build-up on motorcycle instruments. Exercise care in parking. Park facing the sun, place an opaque object over the instruments, or adjust the windshield to avoid reflections.

NOTICE

Use only Harley-Davidson recommended products on Harley-Davidson windshields. Do not use harsh chemicals or rain sheeting products, which can cause windshield surface damage, such as dulling or hazing. (00231c)

Do not clean polycarbonate in hot sun or high temperature. Powdered, abrasive or alkaline cleanser will damage the windshield. Never scrape the windshield with a razor blade or other sharp instruments because permanent damage will result.

NOTE

Covering the windshield with a clean, wet cloth for about 15 minutes before washing will make dried bug removal easier.

Harley-Davidson Windshield Water Repellent Treatment Part Number 99841-01 is approved for use on Harley-Davidson windshields.

SERVICE PARTS

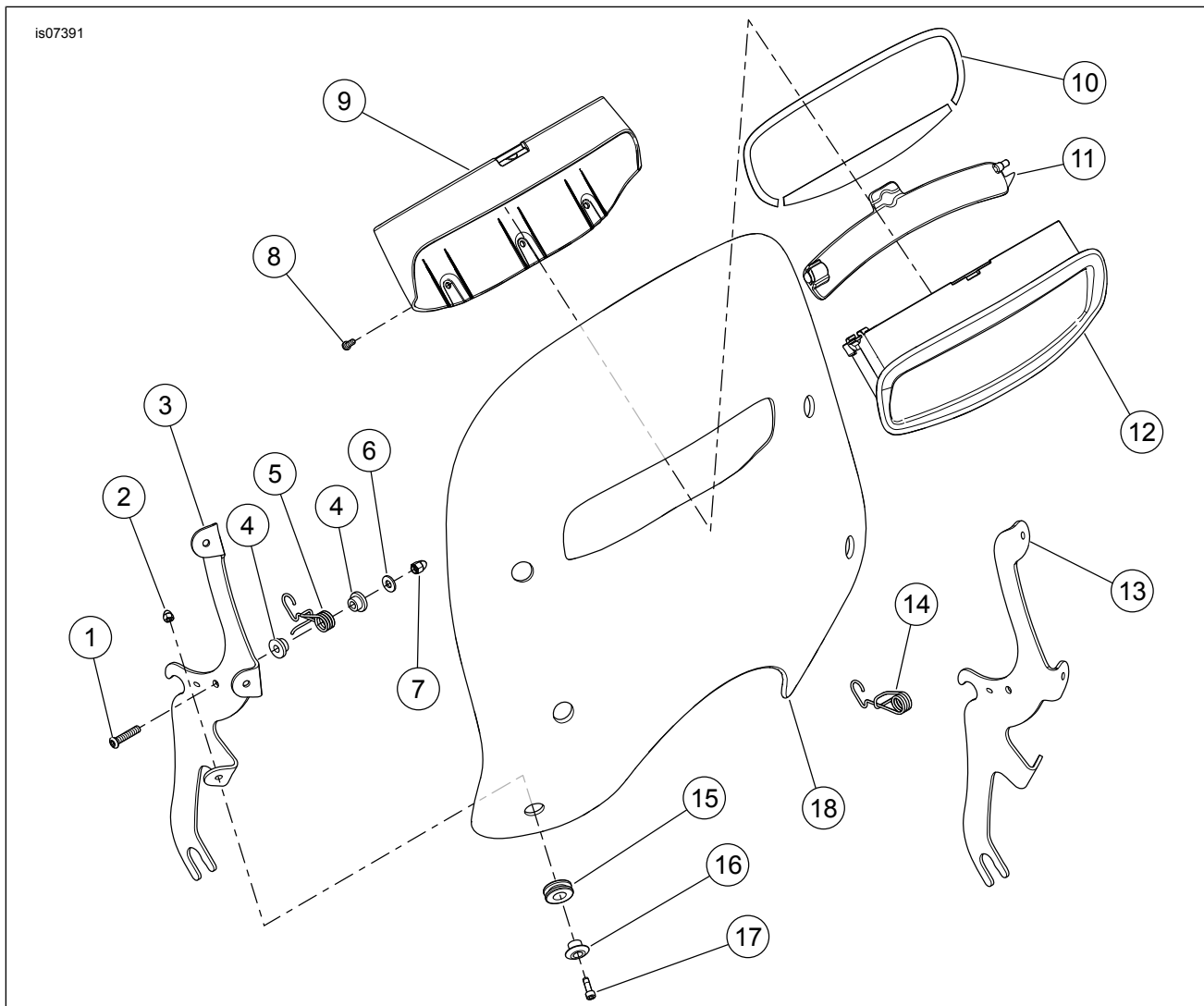

Figure 1. Service Parts: Vented Detachable Windshield

Table 1. Service Parts Table

| Item | Description (Quantity) | Part Number | Item | Description (Quantity) | Part Number |
|------|--|---------------------|------|------------------------|-------------|
| 1 | Screw, button head (2) | 94426-95 | 10 | Tape (1) | 57400175 |
| 2 | Nut, acorn (6) | 7154M | 11 | Air duct vane (1) | 29200029 |
| 3 | Windshield mounting bracket, right (1) | Not sold separately | 12 | Air duct vent (1) | 29200027 |

Table 1. Service Parts Table

| Item | Description (Quantity) | Part Number | Item | Description (Quantity) | Part Number |
|------|------------------------|-------------|------|---------------------------------------|---------------------|
| 4 | Bushing (4) | 58272-95 | 13 | Windshield mounting bracket, left (1) | Not sold separately |
| 5 | Retainer, right (1) | 58253-95 | 14 | Retainer, left (1) | 58252-95 |
| 6 | Washer (2) | 6703 | 15 | Grommet (6) | 11564 |
| 7 | Nut, acorn (2) | 94004-90T | 16 | Mount (6) | 57400178 |
| 8 | Screw (6) | 10200204 | 17 | Windshield mounting screw (6) | 10200218 |
| 9 | Air duct shroud (1) | 29200028 | 18 | Windshield (1) | Not sold separately |

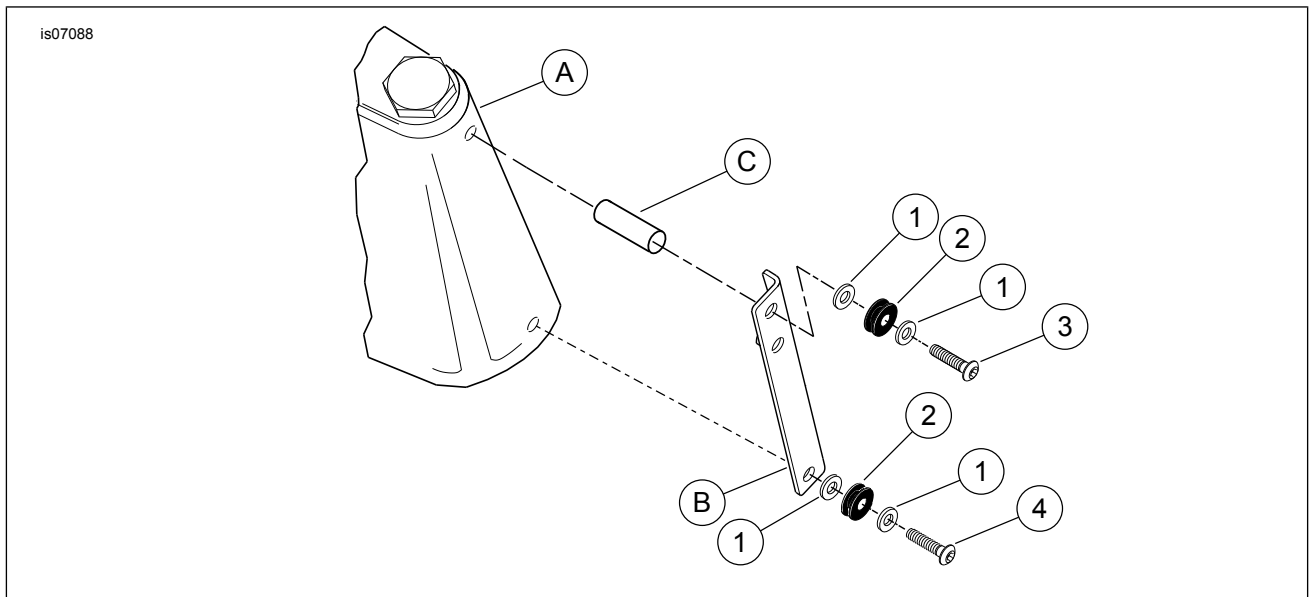

Figure 2. Service Parts: Hardware Kit

Table 2. Service Parts Table

| Item | Description (Quantity) | Part Number |
|---------------------------------|-----------------------------------|-------------|
| | Windshield service kit (1) | 57400195 |
| 1 | • Washer, 0.105 inch (2.7 mm) (8) | 6400HB |
| 2 | • Bushing (4) | 67621-94 |
| 3 | • Screw, button head, 1 3/4 inch | 4343 |
| 4 | • Screw, button head, 1 3/8 inch | 4482 |
| Items mentioned in text: | | |
| A | Decorative triple clamp cover | |
| B | Fog/Passing lamp bracket | |
| C | Original equipment spacer | |