



INSTRUCTIONS

-J00718

REV. 2006-01-12

FLHR WINDSHIELD KITS

GENERAL

Kit Number

57981-97, 57994-94, 57995-96, 57767-00, 58163-02, 58731-02, 58796-02 and 57807-04

Models

These kits fit 1994 and later FLHR model motorcycles.

Table 1. Models

Kits	Contents
57981-97	Low profile smoked windshield
57767-00	Low profile clear windshield
57994-94	Standard height clear windshield
57995-96	Tall clear windshield
58163-02	Road King wind deflector, dark, smoked
58731-02	Road King wind deflector, clear, international
58796-02	Road King wind deflector, dark smoked, 3 inches oversized
57807-04	Standard height clear windshield with flames

CAUTION

Do not use windshield bags with flamed windshields. Damage to graphics will occur. (00393f)

Kit Contents

See Figure 1 and Table 2, Figure 2 and Table 3.

INSTALLATION

1. Lower the windshield into position by carefully inserting the side brackets between the headlamp housing and the passing lamp supports until the bottom notches are seated on the lower grommets. Be sure that the notches on each bracket are firmly seated on a rubber grommet.
2. Standing at the front of the motorcycle, gently push the top of the windshield toward the rear until the upper notches fully engage the upper grommets.
3. Push down on the wireform latch springs so that they overhang the rubber grommets. If some adjustment is necessary, loosen the retaining bolts and rotate the latch springs into the proper position.

WARNING

Improper installation of accessories or loading of cargo can affect motorcycle stability and handling, which could result in death or serious injury. (00455b)

WARNING

Failure to provide adequate clearance between stationary and moving parts can cause loss of control, which could result in death or serious injury. (00378a)

NOTE

Inspect windshield upon completion of installation. Be sure windshield mounting does not restrict full left or full right movement of front fork assembly. If restriction does occur, adjust windshield as needed until proper clearance is obtained. Have experienced Harley-Davidson service personnel correct any problems before riding with this accessory installed.

NOTE

Check mounting hardware periodically. Never ride with loose mounts. A loose mounting causes extra stress on all other mounts, as well as the windshield itself, and could result in premature failure of components.

CARE AND CLEANING

NOTE

Sunlight reflections off of the inside curvature of a windshield can, at certain times of the day, cause extreme heat build-up on motorcycle instruments. Exercise care in parking. Park facing the sun, place an opaque object over the instruments, or adjust the windshield to avoid reflections.

CAUTION

Harley-Davidson windshields are made of Lexan. Lexan is a more durable and distortion-resistant material than other types of motorcycle windshield material, but still requires attention and care to maintain. Failure to maintain Lexan properly can result in damage to the windshield. (00230a)

CAUTION

Do not use harsh chemicals including rain sheeting products on Harley-Davidson windshields. They can cause dulling or hazing. If you want to use a windshield protectant on your windshield, try Harley Glaze Polish and Sealant (00231a)

CAUTION

Do not use benzine, paint thinner, gasoline or any other type of harsh cleaner on the windshield. Doing so will damage the windshield surface. (00232a)

Do not clean Lexan® polycarbonate in hot sun or high temperature. Powdered, abrasive or alkaline cleanser will damage the windshield. Never scrape the windshield with a razor blade or other sharp instruments because permanent damage will result.

NOTES

Covering the windshield with a clean, wet cloth for about 15 minutes before washing will make dried bug removal easier.

Harley-Davidson Windshield Water Repellent Treatment Part Number 99841-01 is approved for use on Harley-Davidson Lexan® windshields.

SERVICE PARTS

NOTE

Typical windshield shown. Actual windshield may vary

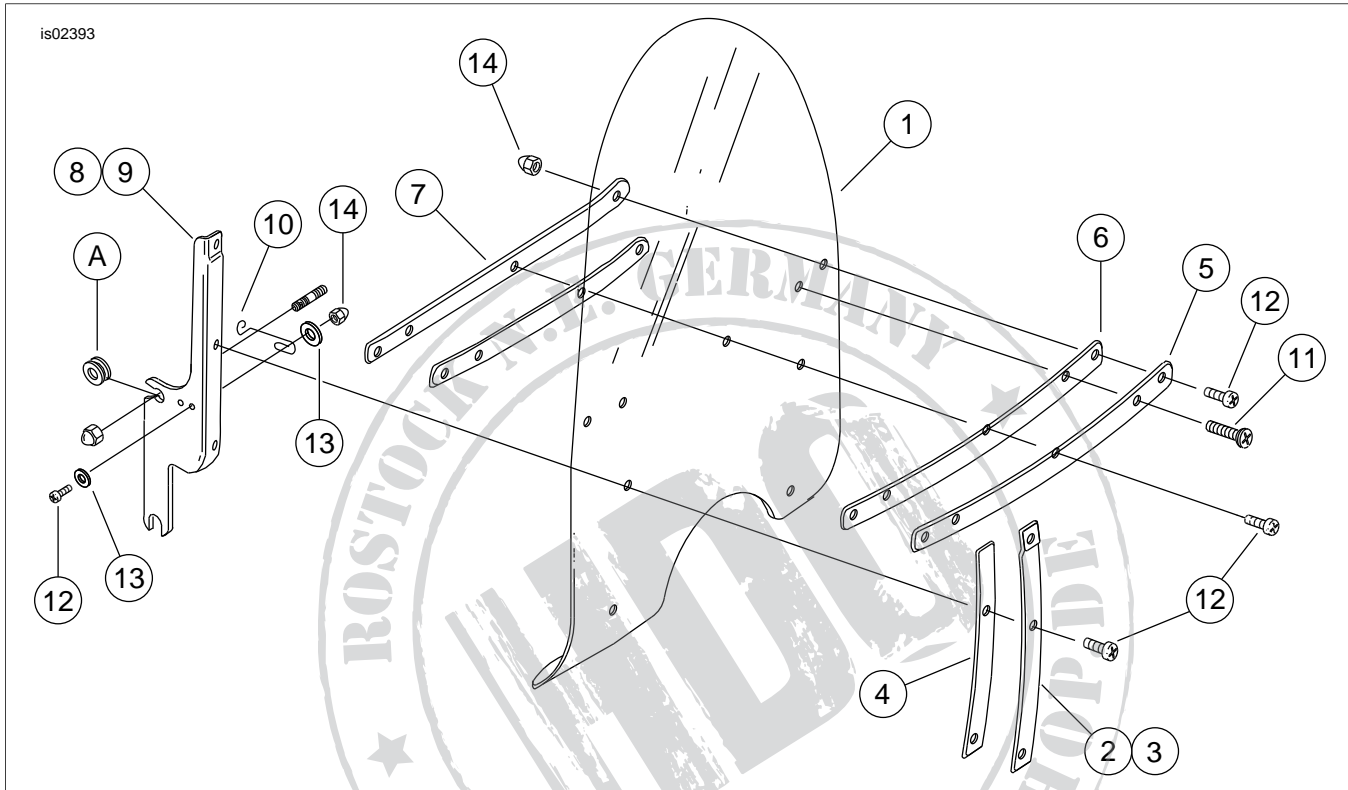

Figure 1. Service Parts: FLHR Windshield Kit

Table 2. Service Parts: FLHR Windshield Kit

Kits 57981-97, 57994-94, 57995-96, 57767-00, 57807-04

Item	Description (Quantity)	Part Number	Item	Description (Quantity)	Part Number
1	Windshield, clear, 2 inches oversize	58433-96	7	Inner horizontal brace	53431-94
	Windshield, clear, standard	58193-94	8	RH bracket	58084-94
	Windshield, clear, 4 inches undersized	57768-00	9	LH bracket	58088-94
	Windshield, smoked, 4 inches undersized	58195-94	10	Spring latches (2)	38722-94
	Windshield, clear with flames	57809-04	11	Panhead Torx screws (2)	2452
2	Outer RH vertical brace	58406-75A	12	Panhead Torx screws (2)	2452
3	Outer LH vertical brace	58408-75A	13	Plain washers (8)	6119
4	Outer vertical brace tape (2)	58417-77	14	Acorn nuts (13)	7651
5	Outer horizontal brace	58428-94	Reference items:		
6	Horizontal brace tape (2)	58416-77A	A	Rubber grommet	

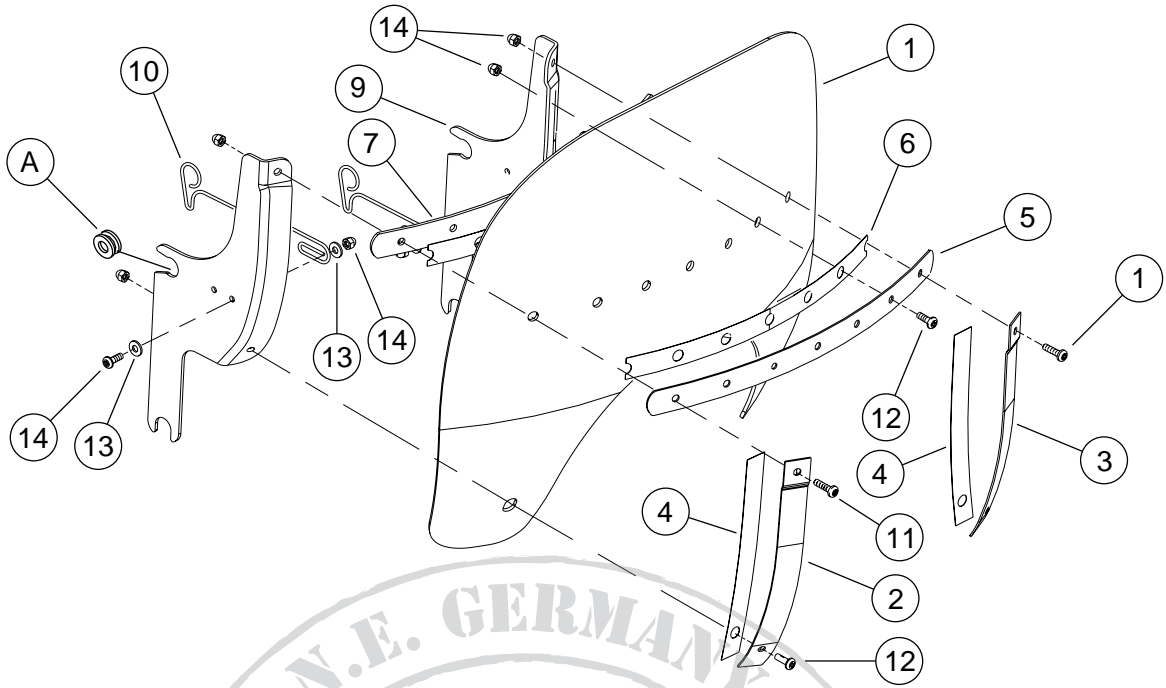

Figure 2. Service Parts: Wind Deflector

Table 3. Service Parts: Wind Deflector

Kits 58163-02, 58731-02, 58796-02					
Item	Description (Quantity)	Part Number	Item	Description (Quantity)	Part Number
1	Wind deflector, smoked	58906-02	8	RH bracket	58542-02
	Wind deflector, clear, international	58908-02	9	LH bracket	58543-02
	Wind deflector, smoked, 3 inch oversized	58799-02	10	Spring latches (2)	38722-94
2	Outer RH vertical brace	58674-02	11	Panhead Torx screws (2)	2452
3	Outer LH vertical brace	58677-02	12	Panhead Torx screws (11)	2921
4	Outer vertical brace tape (2)	58664-02	13	Plain washers (8)	6119
5	Outer horizontal brace	58476-02	14	Acorn nuts (13)	7651
6	Horizontal brace tape (2)	58573-02	Reference items:		
7	Inner horizontal brace	58462-02	A	Rubber grommet	