



INSTRUCTIONS

-J03350

REV. 05-25-2004

Kit Number 56735-04 and 56799-04

SPORTSTER HAND GRIPS

General

This kit fits all 1996 and later model motorcycles.

NOTE

Right handlebar switch removal requires a Service Manual for your model and year of motorcycle. A Service Manual can be purchased from your Harley-Davidson Dealer.

NOTE

See the service parts illustration on the last page of these instructions for kit contents.

Remove and Install the Left Grip

1. See Figure 1. Using a T27 TORX® drive head, remove the two screws with flat washers securing the handlebar clamp (3) to the clutch lever bracket. Remove the clamp and position the clutch hand lever assembly away from the handlebar.
2. Using a T25 TORX® drive head, loosen but do not remove the upper and lower switch housing screws (1).
3. Remove the end cap from the existing left handlebar grip if so equipped. Remove the grip by carefully cutting it away from the handlebar using a sharp blade or knife.

⚠ WARNING

Do not lubricate left handlebar grip before installation. Lubricating grip can cause it to come off while riding, which could result in loss of control and death or serious injury. (00315a)

NOTE

Make sure that the handlebar surface and the inside of the grip are smooth, dry and thoroughly cleaned of all dirt or adhesive residue.

4. Position the new left grip (4) so the larger flange (5) is at the bottom. Push the grip fully onto the handlebar.
5. Fit the grooves (2) on the outboard side of the upper and lower switch housing over the flanges on the end of the grip, then loosely fasten the two screws.
6. Position the clutch hand lever assembly inboard of the switch housing assembly, engaging the tab on the lower switch housing in the groove at the bottom of the clutch lever bracket.
7. Align the holes in the handlebar clamp with those in the clutch lever bracket, and loosely fasten the two screws with flat washers. Adjust the switch housing and clutch hand control position for rider comfort.
8. Using a T27 TORX® drive head, tighten first the upper, then the lower handlebar clamp screws to 60-80 **in-lbs** (6.8-9.0 Nm).

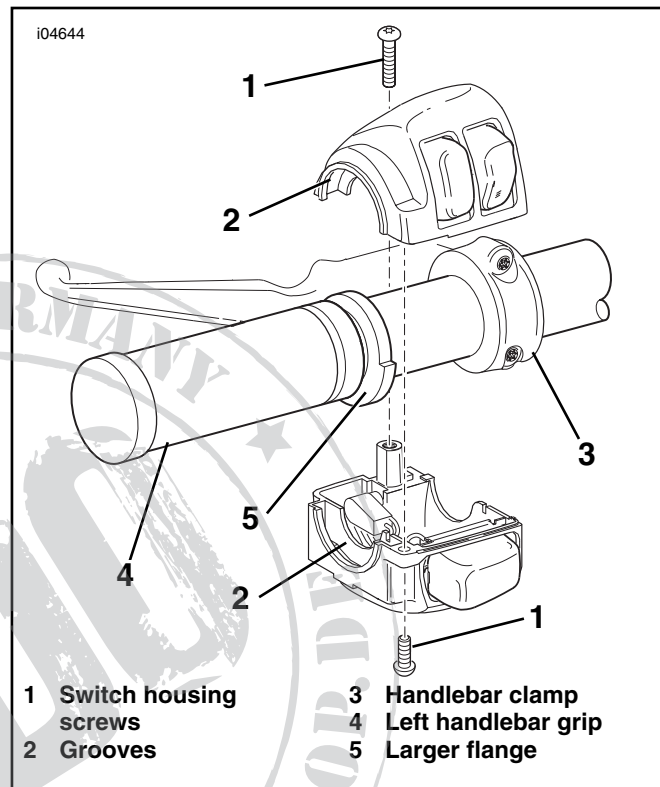

Figure 1. Left Handlebar Switch Housing

9. Using a T25 TORX® drive head, tighten first the lower, then the upper switch housing screws to 35-45 **in-lbs** (4.0-5.1 Nm).

Remove and Install the Right Grip

1. Refer to the RIGHT HANDLEBAR SWITCH section of the service manual for removal of the switch housing assembly. This is necessary to access the throttle cables.
2. Refer to the THROTTLE CONTROL section of the service manual to disconnect the throttle cables and remove the existing right grip/throttle sleeve assembly. After removal, make sure that the handlebar end is clean and smooth.
3. Follow instructions in the service manual to install the new right grip/throttle sleeve to the handlebar and connect the throttle cables.
4. Verify that the right grip/throttle sleeve rotates and returns freely and does not bind on the handlebar or switch housing.



Service Parts

Part Number - See Below

Date 05/04

Handlebar Grips

106288

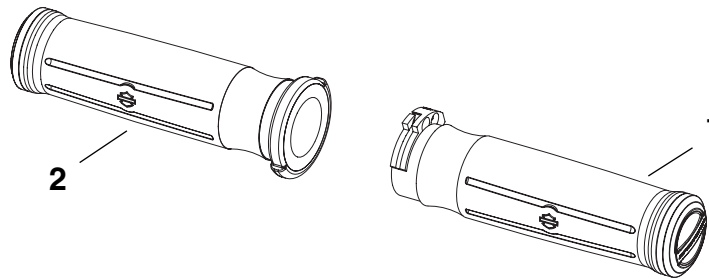

NOTE

Each grip comes with an end cap and is non-removable and bonded.

Kit Number 56735-04, sportster

Item	Description	Part Number
1	Right grip/throttle sleeve (with end cap)	56795-04
2	Left grip (with end cap)	56796-04

Kit Number 56799-04, sportster

Item	Description	Part Number
1	Right grip/throttle sleeve (with end cap)	56797-04
2	Left grip (with end cap)	56798-04

