



INSTRUCTIONS

-J02842

REV. 2011-05-30

HANDLEBAR GRIPS

GENERAL

Kit Number

55869-10, 56197-98A, 56199-98A, 56246-96A, 56254-09, 56263-96A, 56275-96B, 56405-08, 56443-00A, 56450-00A, 56459-01A, 56711-03, 56729-04, 56740-04, 56741-04, 56751-04, 56757-05, 56869-06, 56909-05, 57052-07, 57202-07, 57454-10, 56100007, 56100008, 56100009, 56100010, 56100029

Models

For model fitment information, see the P&A Retail Catalog or the Parts and Accessories section of www.harley-davidson.com (English only).

Kit Contents

See Figure 2 and Table 1.

Additional Parts Required

WARNING

The rider's safety depends upon the correct installation of this kit. Use the appropriate service manual procedures. If the procedure is not within your capabilities or you do not have the correct tools, have a Harley-Davidson dealer perform the installation. Improper installation of this kit could result in death or serious injury. (00333a)

NOTE

Removal of the right handlebar switch removal requires a service manual for your model and year of motorcycle. A service manual can be purchased from a Harley-Davidson dealer.

INSTALLATION

Remove and Install the Left Grip

1. See Figure 1. Remove the two screws with flat washers securing the handlebar clamp (3) to the clutch lever bracket. Remove the clamp and position the clutch hand lever assembly away from the handlebar.
2. Loosen, but do not remove, the upper and lower switch housing screws (1).
3. Remove the end cap from the existing left handlebar grip if equipped. Remove the grip by carefully cutting it away from the handlebar using a sharp blade or knife.

WARNING

Do not lubricate left handlebar grip before installation. Lubricating grip can cause it to come off while riding, which could result in loss of control and death or serious injury. (00315a)

NOTE

Make sure that the handlebar surface and the inside of the grip are smooth, dry and thoroughly cleaned of all dirt or adhesive residue.

4. Position the new left grip (4) so the larger flange (5) is at the bottom. Push the grip fully onto the handlebar.
5. Fit the grooves (2) on the outboard side of the upper and lower switch housing over the flanges on the end of the grip, then loosely fasten the two screws.
6. Position the clutch hand lever assembly inboard of the switch housing assembly, engaging the tab on the lower switch housing in the groove at the bottom of the clutch lever bracket.
7. Align the holes in the handlebar clamp with those in the clutch lever bracket, and loosely fasten the two screws with flat washers. Adjust the switch housing and clutch hand control position for rider comfort.
8. Tighten first the upper, then the lower handlebar clamp screws to 60-80 **in-lb** (6.8-9 Nm).
9. Tighten first the lower, then the upper switch housing screws to 35-45 **in-lb** (4-5.4 Nm).

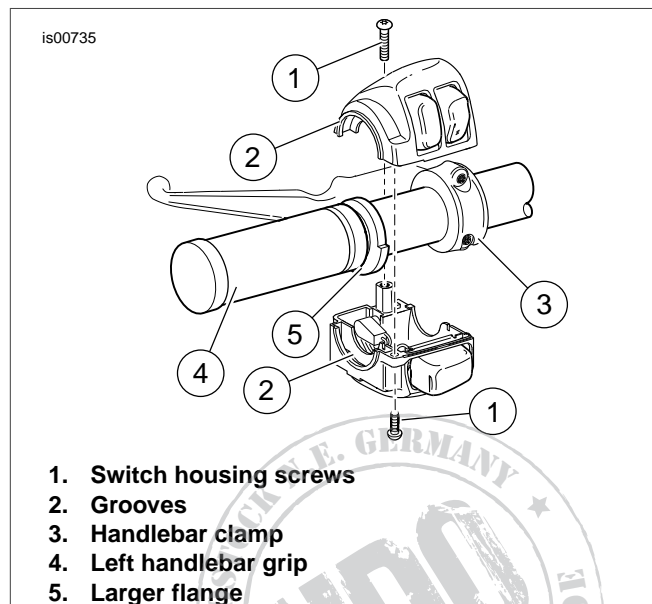

Figure 1. Left Handlebar Switch Housing

Remove and Install the Right Grip

1. Refer to the service manual for removal of the switch housing assembly. This is necessary to access the throttle cables.
2. Refer to the service manual to disconnect the throttle cables and remove the existing right grip/throttle sleeve

assembly. After removal, make sure that the handlebar end is clean and smooth.

- Follow instructions in the service manual to install the new right grip/throttle sleeve to the handlebar and connect the throttle cables.

WARNING

Before starting engine, be sure throttle control will snap back to idle position when released. A throttle control that prevents engine from automatically returning to idle can lead to loss of control, which could result in death or serious injury. (00390a)

- Verify that the right grip/throttle sleeve rotates and returns freely and does not bind on the handlebar or switch housing.

SERVICE PARTS

NOTES

Most end caps are available separately.

Black billet grips in Kit 56405-08 are designed to show signs of wear. Over time the paint will wear off giving a distressed look.

Silencer grips in Kit 55869-10 can be cleaned with Harley® Bright™ Metal Polish (H-D Part No. 99725-89) OR S100® Polishing Soap (H-D Part No. 99779-04).

For illustration purposes, generic-styled hand grips are shown.

If the kit part number does not appear in Table 1, the end cap is not serviceable.

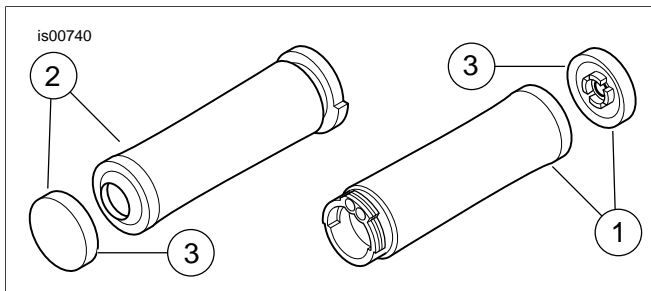

Figure 2. Service Parts: Handlebar Grips

Table 1. Service Parts

Kit	Item 3 (End Cap) Part Number
Kit 55869-10 (Silencer)	Not Sold Separately
Kit 56197-98A (Leather)	56193-98
Kit 56199-98A (Pig Skin)	56193-98
Kit 56246-96A (Chrome & Rubber, Small)	56252-96
Kit 56254-09 (Tribal)	56769-09
Kit 56263-96A (Chrome & Rubber, Large)	56252-96
Kit 56275-96B (Nostalgic)	Not Sold Separately
Kit 56405-08 (Diamond Black)	56464-08
Kit 56443-00A (Billet, Narrow Band)	56446-03
Kit 56450-00A (Billet, Wide Band)	56446-03
Kit 56459-01A (Contoured Chrome & Rubber)	56480-01
Kit 56729-04 (Stealth)	56480-01
Kit 56740-04 (Skull, Medium)	56754-04
Kit 56741-04 (Skull, Large)	56755-04
Kit 56757-05 (Stitched)	56788-05
Kit 56869-06 (Knurled, H-D® Scripted)	56480-01
Kit 56909-05 (Flame, Faded)	56656-02
Kit 57202-07 (Ironside)	56480-01
Kit 57454-10 (Edge Cut)	Not Sold Separately
Kit 56100007 (Get-A-Grip, Chrome)	Not Sold Separately
Kit 56100008 (Get-A-Grip, Black)	Not Sold Separately
Kit 56100009 (Get-A-Grip, Chrome, Large)	Not Sold Separately
Kit 56100010 (Get-A-Grip, Black, Large)	Not Sold Separately
Kit 56100029 (Slipstream)	Not Sold Separately

NOTE: Hand grips (Items 1 and 2) are **NOT** sold separately.

