



# INSTRUCTIONS

-J04258

REV. 2011-05-30

## HANDLEBAR GRIPS

### GENERAL

#### Kit Numbers

56246-08, 56263-08, 56275-08, 56425-08, 56459-08, 56518-08, 56729-08, 56740-08, 57202-08, 56746-08, 56257-09, 57457-10, 56100015, 56100036, 56100028

#### Models

For model fitment information, see the P&A Retail Catalog or the Parts and Accessories section of [www.harley-davidson.com](http://www.harley-davidson.com) (English only).

#### Kit Contents

See Figure 2 and Table 1.

#### Additional Parts Required

### WARNING

The rider's safety depends upon the correct installation of this kit. Use the appropriate service manual procedures. If the procedure is not within your capabilities or you do not have the correct tools, have a Harley-Davidson dealer perform the installation. Improper installation of this kit could result in death or serious injury. (00333a)

This instruction sheet references service manual information. A service manual for your model motorcycle is required for this installation and is available from a Harley-Davidson dealer.

### INSTALLATION

#### Remove and Install the Left Side Grip

1. See Figure 1. Remove the upper and lower switch housing screws (1).
2. Loosen the upper screw securing the handlebar clamp (3) to the clutch lever bracket. Remove the lower clamp screw and flat washer. Loosen the clamp and position the clutch hand lever assembly away from the switch housing. Separate the upper and lower switch housings.
3. Remove the end cap from the existing left handlebar grip if equipped.

**With glueless grip:** Remove the grip from the handlebar.

**With glued grip:** Remove the grip by carefully cutting it away from the handlebar using a sharp blade or knife.

### WARNING

Do not lubricate left handlebar grip before installation. Lubricating grip can cause it to come off while riding, which could result in loss of control and death or serious injury. (00315a)

#### NOTE

Verify that the handlebar surface is smooth, dry and thoroughly cleaned of all dirt or adhesive residue.

4. Position the new left grip (4) so the larger diameter portion of the flange (5) is at the bottom. Push the grip fully onto the handlebar.

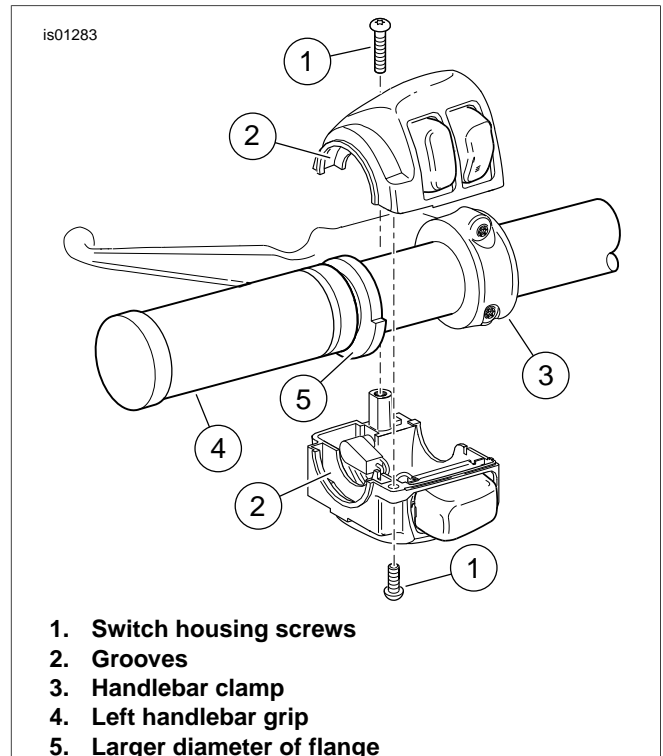

Figure 1. Left Handlebar Switch Housing

5. Position the lower switch housing beneath the grip so that the grooves (2) on the outboard side of the switch housing fit over the flange on the end of the grip.
6. Position the upper switch housing over the handlebar and lower switch housing.
7. Start the upper and lower switch housing screws, but do not tighten. Verify that the wire harness conduit runs in the depression at the bottom of the handlebar.
8. Position the clutch hand lever assembly inboard of the switch housing assembly, engaging the tab on the lower switch housing in the groove at the bottom of the clutch lever bracket.
9. Align the hole in the handlebar clamp with the hole in the clutch lever bracket, and start the lower screw with flat washer. Adjust the switch housing and clutch hand control position for rider comfort.

10. Tighten first the upper, then the lower handlebar clamp screws to 60-80 **in-lbs** (6.8-9 Nm).

11. Tighten first the lower, then the upper switch housing screws to 35-45 **in-lbs** (4-5.4 Nm).

### Remove and Install the Right Side Grip

**NOTICE**

**Do not remove or install the master cylinder assembly without first positioning a 5/32-inch (4 mm) thick insert between the brake lever and lever bracket. Removing or installing the master cylinder assembly without the insert in place may result in damage to the rubber boot and plunger on the front stoplight switch. (00324a)**

1. See the service manual and follow the instructions to remove and install the switch housings and the right side grip (throttle twist grip).
2. Adjust the switch housing and brake hand control position for rider comfort.
3. Tighten first the upper, then the lower handlebar clamp screws to 60-80 **in-lbs** (6.8-9 Nm).
4. Tighten first the lower, then the upper switch housing screws to 35-45 **in-lbs** (4-5.4 Nm).

**WARNING**

**Before starting engine, be sure throttle control will snap back to idle position when released. A throttle control that prevents engine from automatically returning to idle can lead to loss of control, which could result in death or serious injury. (00390a)**

5. Verify that the right grip/throttle sleeve rotates and returns freely and does not bind on the handlebar or switch housing.

### SERVICE PARTS

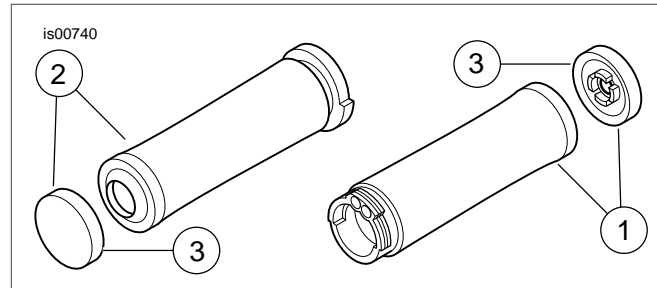

**Figure 2. Service Parts: Handlebar Grips (Generic Style Shown)**

**NOTES**

*For illustration purposes, generic-styled handlebar grips are shown.*

*Each grip includes a replaceable end cap, except for Nostalgic, Aileron, Edge Cut, Get-A-Grip and Slipstream grips which have closed ends.*

**Table 1. Service Parts Table**

Kit	Item	Description (Quantity)	Part Number
Kit 56246-08	3	End cap, Chrome and Rubber, small	56252-96
Kit 56257-09	3	End cap, Tribal	56769-09
Kit 56263-08	3	End cap, Chrome and Rubber, large	56252-96
Kit 56459-08	3	End cap, Contoured Chrome and Rubber	56480-01
Kit 56518-08	3	End cap, Flame	56656-02
Kit 56729-08	3	End cap, Stealth	56480-01
Kit 56740-08	3	End cap, Skull, medium	56754-04
Kit 57202-08	3	End cap, Ironside	56480-01
Kit 56746-08	3	End cap, Diamond Black	56464-08
Kit 57457-10	3	End cap, Edge Cut	Not Sold Separately
Kit 56425-08	3	End cap, Aileron	Not Sold Separately
Kit 56275-08	3	End cap, Nostalgic	Not Sold Separately
Kit 56100015	3	End cap, Get-A-Grip, chrome, large	Not Sold Separately
Kit 56100036	3	End cap, Get-A-Grip, black, large	Not Sold Separately
Kit 56100028	3	End cap, Slipstream	Not Sold Separately

NOTE: Hand grips (Items 1 and 2) are **NOT** sold separately.