



INSTRUCTIONS

-J04403

REV. 2008-04-18

CHROME 1.00 INCH (25.4 MM) DIAMETER HANDLEBAR KITS

GENERAL

Kit Numbers

56166-08, 56180-08, 56941-09

Models

For model fitment information, please see the P&A Retail Catalog or the Parts and Accessories section of www.harley-davidson.com (English only).

This kit does not fit models equipped with Hydraulic Clutch Kits, handlebar mounted gauges or the Road Tech® Radio.

NOTES

Instructions are provided for mounting Handlebar Kits 56166-08 and 56180-08 with INTERNAL or EXTERNAL handlebar-switch wiring.

Handlebar Kit 56941-09 **MUST** be installed with **INTERNAL HANDLEBAR-SWITCH WIRING ONLY**.

Heated Hand Grips **CANNOT** be used on handlebars with internal handlebar-switch wires.

Additional Parts or Accessories Required

Separate purchase of additional parts or accessories is required for proper installation of this Handlebar Kit on your model motorcycle. Please see the P&A Retail Catalog or the Parts and Accessories section of www.harley-davidson.com (English only) for a list of required parts or accessories for your model.

For Australia, Brazil, England, Europe and Japan, two special screws (Part Number 2935A) will also be required.

Tools and Supplies Required

Loctite® 271 (Red) Threadlocker and Sealant (H-D Part Number 99671-97) is required for the proper installation of this kit.

Fresh, uncontaminated DOT 4 brake fluid from a sealed container will also be needed.

⚠ WARNING

Replace brake line gaskets. Re-using original gaskets can cause brake failure and loss of vehicle control, which could result in death or serious injury. (00318a)

For models that re-use the original brake line, the two brake-line gaskets found at each banjo fitting **must be replaced**. Refer to the appropriate Parts Catalog or see a Harley-Davidson dealer for the correct part numbers.

Motorcycles equipped with a **glued** left-side hand grip will also require a new grip, sold separately. Refer to the Parts Catalog for replacement stock hand grips.

Ask a Harley-Davidson dealer about the selection of Genuine Motor Accessory hand grips that are available.

-J04403

NOTE

Heated Hand Grips **CANNOT** be used on handlebars with internal handlebar-switch wires.

⚠ WARNING

The rider's safety depends upon the correct installation of this kit. Use the appropriate service manual procedures. If the procedure is not within your capabilities or you do not have the correct tools, have a Harley-Davidson dealer perform the installation. Improper installation of this kit could result in death or serious injury. (00333a)

NOTE

This instruction sheet references Service Manual information. A Service Manual for your model motorcycle is required for this installation and is available from a Harley-Davidson Dealer.

Kit Contents

See Figure 5 and Table 1.

INSTALLATION

Preparation

⚠ WARNING

To prevent accidental vehicle start-up, which could cause death or serious injury, remove main fuse before proceeding. (00251b)

1. Refer to the Service Manual and follow the instructions given to remove the main fuse.
2. **For FLTR models only:** Refer to UPPER FAIRING AND WINDSHIELD: FLTR: OUTER FAIRING: REMOVAL in the Service Manual, and follow the instructions to remove the outer fairing.
See INSTRUMENT NACELLE: FLTR: REMOVAL in the Service Manual, and remove the instrument nacelle and bezel.

For ALL models:

⚠ CAUTION

Direct contact of D.O.T. 4 brake fluid with eyes can cause irritation. Avoid eye contact. In case of eye contact flush with large amounts of water and get medical attention. Swallowing large amounts of D.O.T. 4 brake fluid can cause digestive discomfort. If swallowed, obtain medical attention. Use in well ventilated area. KEEP OUT OF REACH OF CHILDREN. (00240a)

CAUTION

D.O.T. 4 brake fluid will damage painted and body panel surfaces it comes in contact with. Always use caution and protect surfaces from spills whenever brake work is performed. Failure to comply can result in cosmetic damage. (00239b)

NOTE

Immediately wipe up any brake fluid spillage with a clean, dry, soft cloth. Follow up by thoroughly wiping affected area with a clean, damp, soft cloth (small spills) or washing with a large quantity of soapy water (large spills).

Cover nearby motorcycle surfaces with a polyethylene protective sheet to help protect against damage to finish caused by spillage or splash of DOT 4 brake fluid.

3. Drain the brake fluid from the front brake reservoir and lines per the instructions in the Service Manual.

Original Handlebar Removal

NOTE

Cover the front fender and the fuel tank with clean shop towels to prevent scratching. Damage to the finish could result.

CAUTION

Remove brake line components carefully. Damage to seating surfaces can cause leakage. (00320a)

1. Using a T-40 TORX® drive head, remove and retain the button head screw on the underside of the fork stem and bracket assembly that holds the brake line manifold tee.
2. Carefully make note of the front brake line routing and the orientation of the banjo fittings. Disconnect the brake line from the front brake calipers and the front brake master cylinder assembly.
Save the banjo bolts, but **discard** the two gaskets found at each banjo fitting. See FRONT BRAKE MASTER CYLINDER in the Service Manual.
3. Remove the front brake line assembly from the motorcycle.

NOTE

Refer to the Parts Catalog for your year and model for a replacement stock brake line assembly, if needed.

Ask a Harley-Davidson dealer about the selection of Genuine Motor Accessory Custom Braided Clutch Cables and Brake Lines that are available.

4. Using a T27 TORX® drive head, remove the front-brake master cylinder and clutch-lever assemblies from the handlebar.

NOTE

Refer to the Parts Catalog for your year and model for a replacement stock clutch cable, if needed.

Ask a Harley-Davidson dealer about the selection of Genuine Motor Accessory Custom Braided Clutch Cables and Brake Lines that are available.

5. Refer to CLUTCH CABLE: REMOVAL in the Service Manual, and follow the instructions to disconnect the clutch cable from the clutch lever.

If the clutch cable is being replaced, follow the instructions to disconnect the clutch cable from the side cover, and remove the cable from the vehicle.

6. **For FLHR/C models only:** Remove the headlamp assembly from the headlamp nacelle. See HEADLAMP in the Service Manual.

7. **For ALL models:** Refer to the MOLEX ELECTRICAL CONNECTORS section of the Service Manual. Disconnect the handlebar control wiring.

- **For FLHR models:** Disconnect the handlebar control wiring from the gray eight-way and black six-way main harness connectors inside the headlamp nacelle.

- **For FLHRC models:** Disconnect the handlebar control wiring from the gray eight-way and black six-way main harness connectors inside the headlamp nacelle.

Disconnect the electronic cruise-control wiring from the two three-way connectors.

- **For FLTR models:** Disconnect the handlebar control wiring from the gray sixteen-way and black twelve-way main harness connectors inside the headlamp nacelle.

8. Refer to the HANDLEBAR SWITCHES; RIGHT HANDLEBAR CONTROLS section of the Service Manual for removal of the right-side switch housing assembly and harness.

9. Refer to the LEFT HANDLEBAR CONTROLS section of the Service Manual for removal of the left-side switch housing assembly and wire harness.

10. If the plastic wiring retainer clips that secured both switch harnesses to the handlebar are still attached to the harnesses or handlebar, remove and discard them.

11. **If the left-side hand grip is not glued to the handlebar:** Remove the end cap from the grip if so equipped.
Remove the hand grip and set it aside for installation onto the new handlebar.

12. Remove the end cap from the existing right handlebar grip if so equipped.
Remove the grip from the handlebar.

NOTES

The twist grip sensor in the right side of the handlebar has a seal cap that protects internal electrodes from dirt and moisture, and also serves as a retention device for the throttle grip.

To remove the grip, a slight tug may be necessary to release the index pins in the grip from the receptacle in the seal cap.

If the throttle grip IS being replaced: Discard the throttle grip and proceed to Step 13.

If the throttle grip IS NOT being replaced: Upon removing the grip, note if the seal cap is attached to the end of the twist grip sensor.

- *If the seal cap is attached to the sensor, proceed to Step 13.*

- *If the seal cap is still fastened to the index pins **inside** the throttle grip, use a stiff piece of mechanics' wire to lasso the seal cap and pull it free of the index pins.*

If the new handlebar is to have INTERNAL handlebar-switch wiring: The original equipment (O.E.) twist grip sensor

MUST be replaced with a new sensor. If carefully removed, the O.E. sensor can be saved for possible re-use at a later time.

If the new handlebar is to have EXTERNAL handlebar-switch wiring: If carefully removed, the original equipment (O.E.) twist grip sensor can be re-used with the new handlebar.

13. Refer to TWIST GRIP SENSOR: REMOVAL in the Service Manual, and follow the instructions for your model motorcycle to remove the O.E. twist grip sensor.

a. Access the six-way twist grip sensor jumper harness connector [204] inside the vehicle, and disconnect the black Molex connector halves.

b. **Gently** pull the twist grip sensor and wires out of the handlebar until the small green connector pair is exposed.

c. **Note:** the external latch on the small green twist grip sensor connector inside the handlebar will break if the twist grip sensor is pulled too hard.

A damaged latch will prevent positive engagement of the pin and socket housings. Since the pin and socket housings are not serviceable, **any damage will render the O.E. twist grip sensor or jumper harness unusable.**

Disconnect the green socket housing on the sensor from the green pin housing on the jumper harness inside the handlebar by **carefully** prying up the latch with a small, flat screwdriver or similar tool.

d. **If the new handlebar is to have EXTERNAL handlebar-switch wiring:** Remove the twist grip sensor from the vehicle and set aside for re-use with the new handlebar.

Pull the jumper harness out through the lower center wire exit slot in the handlebar and set aside for re-use with the new handlebar.

If the new handlebar is to have INTERNAL handlebar-switch wiring: Remove the twist grip sensor from the vehicle and set aside for possible future use.

Pull the jumper harness out through the lower center wire exit slot in the handlebar and set aside for possible future use.

14. **For FLTR models:** Proceed to Step 18.

For FLHR/C models: See Figure 1. Reaching inside the headlamp nacelle (5), remove the flange nut (7) to release the trim strip (6) at the top of the nacelle.

Retain the nut and trim strip for re-assembly.

15. Carefully pry off the fork-lock label plate (4) from the stock handlebar cover (2). Remove the entire plastic plate; do not remove the adhesive label from the plate.

16. **For North America:** Remove and retain the two Phillips flat head screws (8) underneath the label plate that hold the handlebar cover to the fork lock.

For Australia, Brazil, England, Europe and Japan, the flat head screws (8) have break-away heads and are not

easily removable. To remove screws with break-away heads:

a. Use a center punch to make a pilot hole at the top of each screw.

b. Insert a 1/8-inch (3 mm) *left-hand* drill bit into a drill, and set the drill to "REVERSE".

c. Position the drill bit in the pilot hole, and power the drill at a slow speed to extract the screw. Repeat for the remaining screw.

If the above method fails, use a 3/16-inch (5 mm) long shank drill bit to carefully drill off the heads of the break-away screws. Use a pliers to unthread the screw shafts from the fork lock.

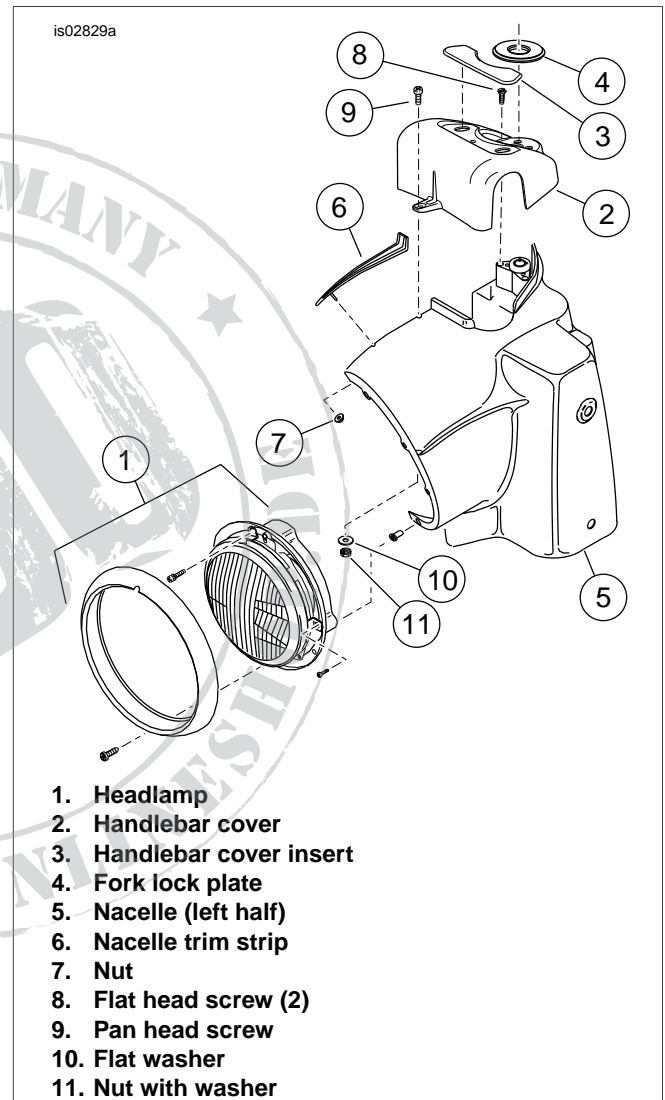

Figure 1. Nacelle, Headlamp and Handlebar Cover (FLHR/C Models)

17. Remove the Phillips pan head screw (9), nut (11) and flat washer (10) holding the front of the handlebar cover (2) to the nacelle.

Retain the handlebar cover, screw, nut and washer for later assembly.

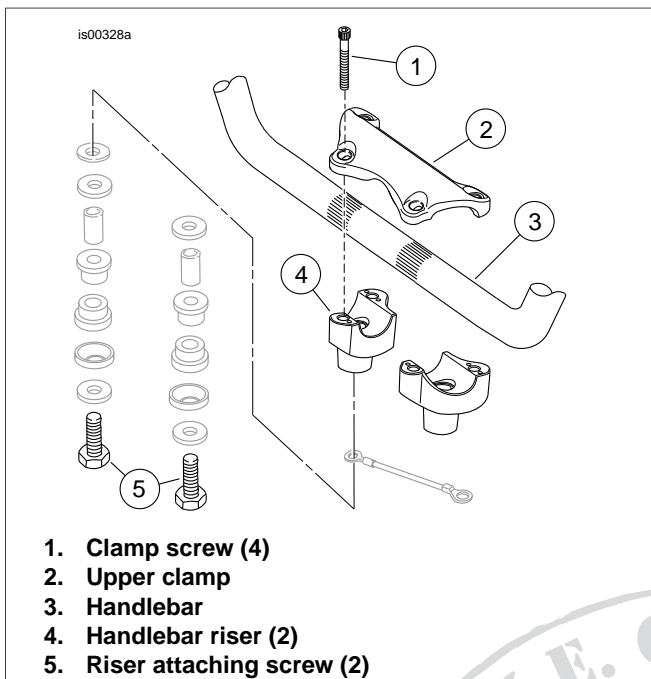

Figure 2. Handlebar Clamp and Risers

18. **For ALL models:** See Figure 2. Remove and retain the screws (1) that fasten the handlebar upper clamp (2) to the risers (4). Remove and retain the clamp. Remove the handlebar (3) from the motorcycle.

NOTE

DO NOT remove the wires from the Molex handlebar switch connector **pin housings** inside the nacelle.

19. Note the wire colors and positions in each cavity of the **socket housings** leading from the switches. Refer to the wiring diagram and the MOLEX ELECTRICAL CONNECTORS section in the Service Manual. Remove the wires (with socket terminals) from the socket housings.

If the new handlebar is to have EXTERNAL handlebar-switch wiring: Proceed to **New Handlebar Wiring, External**.

20. **If the new handlebar is to have INTERNAL handlebar-switch wiring:** Use tape to wrap the wire terminal ends **from each source** to make separate leaders. Wrap each leader tight enough to enter the wire entrance hole at the handlebar switch location, and pass easily through the **new** handlebar.

New Handlebar Wiring, Internal

NOTE

Handlebar Kit 56941-09 **MUST** be installed with **INTERNAL HANDLEBAR-SWITCH WIRING ONLY**.

1. Obtain three pieces of string, mechanics' wire or equivalent, each of sufficient length to extend inside the handlebar, from the end of the bar to the lower center wire

slot, plus six to twelve inches (15-30 cm) of additional length to extend beyond the openings.

- a. Tie a small weight (for example, a spare nut or washer small enough to fit through the center wire slot) to one end of **each** string.

- b. Insert the weighted end of **two** of the strings into the **right-side** handlebar end, and tip the handlebar so that the weights and strings slide down the handlebar to the lower center wire slot.

If necessary, an air hose can be used to blow the weights and strings through the handlebar to the center slot.

- c. While ensuring that the **non-weighted ends** of the strings remain extended out of the right-side handlebar end, pull the **weighted ends** out of the lower center wire slot. Remove the weights from the strings.

- d. With a tweezers or similar tool, fish **one** string out through the **switch** wiring slot near the right-side handlebar end.

Allow the second string to remain extended out of the right-side handlebar end.

- e. Repeat Steps 1b through 1d with the one remaining string and the **left-side** handlebar end.

Fish the string out through the **switch** wiring slot near the left-side handlebar end.

2. If not already done, remove the plastic wiring retainer clips that secured both handlebar switch harnesses to the original handlebar.

For Kit 56941-09 only:

NOTE

Pay attention to the style and orientation of the grommets so they will install into the switch harness slots correctly when the wire harnesses have been pulled through.

3. See Figure 5. Slide the full flanged left-side grommet (4), flange end first onto the **left-side** switch-wire bundle, positioning the grommet close to the switch end.

Slide the partial flanged right-side grommet (5), flange end first onto the **right-side** switch-wire bundle, positioning the grommet close to the switch end, with the flange oriented toward the center of the handlebar.

For ALL Kits:

NOTE

DO NOT attempt to re-use the O.E. twist grip sensor with the new handlebar. The small green connector on the O.E. sensor is not compatible with internal handlebar-switch wiring. The O.E. sensor **MUST** be replaced with a **new** sensor (Part Number 32310-08), sold separately.

4. Obtain the Twist Grip Sensor Kit (purchased separately).

Use tape to wrap the wire terminals on the ends of the Twist Grip Sensor wires to make a single leader. Wrap the leader tight enough to pass easily through the **new** handlebar.

5. Tie the end of the string from the right-side **handlebar end** hole to the Twist Grip Sensor wire bundle.

6. Tie the end of the string from the right-side **switch wire** hole to the right-side switch wire bundle.

- Apply a **light** coat of liquid soap, window cleaner, or all-purpose lubricant such as WD-40®, to the right-side switch and Twist Grip Sensor wire bundles.

⚠ WARNING

Wiring in the switch housings must be routed exactly as shown. Pinch points in the switch housings can short-circuit or sever wires, which could cause loss of control resulting in death or serious injury. (00415b)

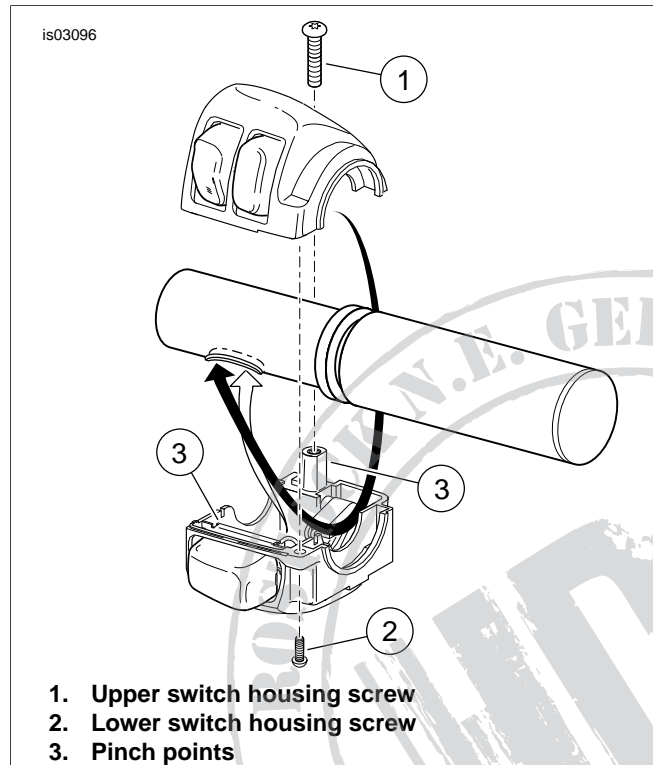

- Upper switch housing screw
- Lower switch housing screw
- Pinch points

Figure 3. Switch-Housing Wire Routing (Right-Side Housing Shown)

- Gently feed the Twist Grip Sensor wire bundle into the right-side handlebar end.
See Figure 3. Route the right-side switch wire bundle through the switch housing as shown. Gently feed the wire bundle into the right-side switch wire hole.
Pull the bundles down through the new handlebar and toward the center of the bar, while fitting the index tabs on the twist grip sensor into the slots on the end of the handlebar. One index tab and slot are smaller than the other to prevent improper assembly.

⚠ WARNING

Carefully pull the wires through hole in handlebar to prevent stripping the wires. Stripped wires can cause short circuits and damage vehicle electrical components, which could cause loss of vehicle control resulting in death or serious injury. (00418b)

- Pull the taped ends of the wire bundles through the wire-exit hole at the bottom center of the handlebar.

The Warning that follows is for Kit 56941-09 only:

⚠ WARNING

Grommets in each of the wiring holes in the handlebar must remain in position after routing the wiring through the handlebar. Operation without the grommets in place can damage wires, causing a short circuit which could result in death or serious injury. (00416d)

- For ALL Kits: Tie the end of the string from the left-side switch wire hole to the left-side switch wire bundle.
- If necessary, apply a **light** coat of liquid soap, window cleaner, or all-purpose lubricant such as WD-40®, to the left-side switch wire bundle.
- Route the left-side switch wire bundle through the switch housing similar to that shown in Figure 3 for the right-side wiring. Gently feed the wire bundle into the left-side switch wire hole.
Pull the bundle down through the new handlebar and toward the center of the bar.

For Kit 56941-09 only:

NOTE

Insert the right-side grommet into the handlebar slot with the flange toward the center of the bar.

- See Figure 5. Insert the switch-wire grommets (4 and 5) into place in the switch-wire holes in the handlebar.
- For ALL Kits: Loosely fasten the brake-lever and clutch-lever clamps to the new handlebar.
- Loosely fasten the handlebar switch housings to the new handlebar.
- Remove the tape from the ends of the wire bundles.
- Check for electrical continuity between the handlebar and each wire in the wire bundles. Continuity would indicate a short circuit, which would require examination of the wires and routing in the switch housing.
Proceed to "New Handlebar Installation".

New Handlebar Wiring, External

NOTE

Handlebar Kit 56941-09 MUST be installed with **INTERNAL HANDLEBAR-SWITCH WIRING ONLY**.

- Obtain a piece of string, mechanics' wire or equivalent, of sufficient length to extend inside the handlebar, from the end of the bar to the lower center wire slot, plus six to twelve inches (15-30 cm) of additional length to extend beyond the openings.
 - Tie a small weight (for example, a spare nut or washer small enough to fit through the center wire slot) to one end of the string.
 - Insert the weighted end of the string into the **right-side** handlebar end, and tip the handlebar so that the weight and string slides down the handlebar to the lower center wire slot.

If necessary, an air hose can be used to blow the weight and string through the handlebar to the lower center wire slot.

- c. While ensuring that the **non-weighted end** of the string remains extended out of the right-side handlebar end, pull the **weighted end** out of the lower center wire slot. Remove the weight from the string.
2. Obtain the Twist Grip Sensor **jumper harness** removed earlier.
Tie the end of the string from the center wire slot to the small green jumper harness pin housing.
3. If necessary, apply a **light** coat of liquid soap, window cleaner, or all-purpose lubricant such as WD-40®, to the jumper harness.

NOTE

The external latch on the green jumper harness pin housing will break if the string is pulled too hard.

A damaged latch will prevent positive engagement of the pin and socket housings. Since the pin housing is not serviceable, any damage will render the O.E. twist grip sensor jumper harness unusable.

4. **Gently** pull the string out through the right-side handlebar end until the green pin housing is exposed.
5. Connect the green socket housing on the Twist Grip Sensor to the green pin housing on the jumper harness.
6. If necessary, apply a **light** coat of liquid soap, window cleaner, or all-purpose lubricant to the Twist Grip Sensor wire bundle.

NOTE

The external latch on the green jumper harness pin housing will break if the jumper harness is pulled too hard, disconnecting the Twist Grip Sensor.

A damaged latch will prevent positive engagement of the pin and socket housings. Since the pin and socket housings are not serviceable, any damage will render the O.E. twist grip sensor or jumper harness unusable.

7. Gently feed the Twist Grip Sensor wiring into the right-side handlebar end.
Carefully pull the wire bundle down through the new handlebar and toward the center of the bar, while fitting the index tabs on the twist grip sensor into the slots on the end of the handlebar. One index tab and slot are smaller than the other to prevent improper assembly.
8. Pull the jumper harness out through the lower center wire exit slot in the handlebar.
9. See Figure 5. Obtain the rubber sleeve (2) from the kit. Cut the sleeve into two equal lengths. Slide a section of the sleeve onto each of the **switch-wire** bundles, over the flexible conduit, positioning the outboard edge of the sleeve against the inboard switch end.

NOTE

The flexible conduit covering the switch wires should extend into the switch housings. The rubber sleeves should be positioned to butt up against the sides of the switch housings.

The sleeves are used to protect the switch wiring against damage from the edges of the wiring slots in the handlebar, and to plug the exposed portion of the slot.

10. To prevent the wiring being pinched by the brake-lever or clutch-lever clamps, push the rubber sleeve-enclosed portion of the switch harness into the wiring slot on the new handlebar, just beneath the handlebar surface.
Hold the harness/rubber sleeve below the surface of the handlebar while loosely fastening the brake-lever or clutch-lever clamp to the handlebar.
11. Repeat Step 10 at the opposite end of the handlebar.
12. Loosely fasten the handlebar switch housings to the new handlebar.

New Handlebar Installation

1. Center the new handlebar on the risers. To make sure that the handlebar is centered, verify that the knurled handlebar areas exposed on the outboard side of each riser are equal.
2. Position the original handlebar upper clamp, and loosely install with the clamp screws saved earlier.

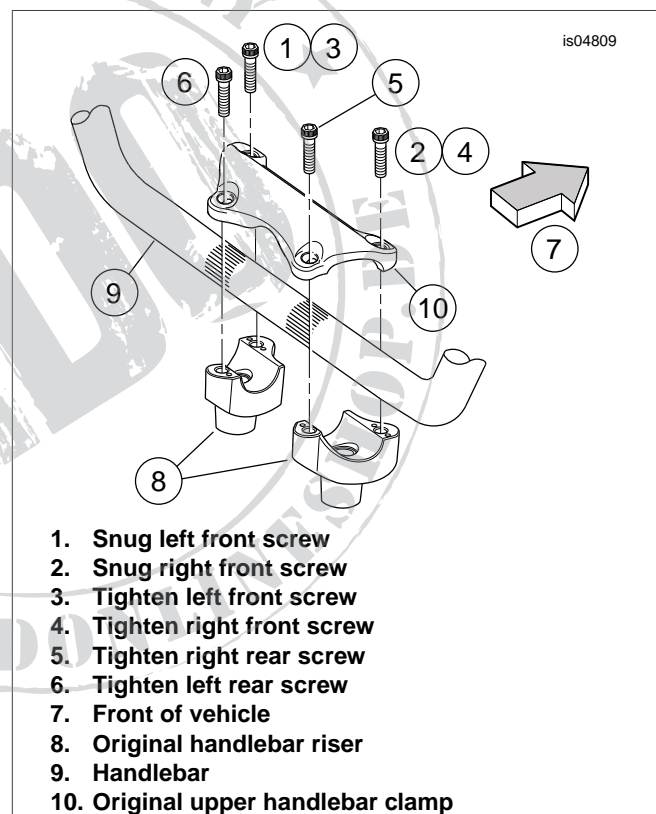

Figure 4. Handlebar Clamp Screw Tightening Sequence

NOTE

The handlebar upper clamp is designed to leave a gap between the clamp and riser to the rear of the handlebar when installed.

3. See Figure 4. Snug, but do not fully tighten, **only** the front two upper clamp screws in the following sequence:
 - a. First, snug the left front screw (1).
 - b. Then, snug the right front screw (2).
4. Refer to the notes made during the removal steps, and the wiring diagram and MOLEX ELECTRICAL CONNEC-

TORS section in the Service Manual. Insert each socket terminal from the left-side switch-wire bundle into the correct cavity of the **gray** socket housing removed earlier.

5. Insert each socket terminal from the right-side switch-wire bundle into the correct cavity of the **black** socket housing removed earlier.
6. Connect the gray handlebar switch-wire socket housing to the gray pin housing inside the nacelle. Connect the black handlebar switch-wire socket housing to the black pin housing inside the nacelle.

For FLHRC models: Connect the three-way cruise control pin and socket housings in the same manner.

7. **If the new handlebar has EXTERNAL handlebar-switch wiring:** Proceed to Step 9.

If the new handlebar has INTERNAL handlebar-switch wiring: Obtain the PVC tubing and the six-way black Molex pin housing from the Twist Grip Sensor Kit (purchased separately). Install the tubing over ALL of the wires coming from the twist grip sensor.

8. Insert each pin terminal from the twist grip sensor into the correct cavity of the pin housing as follows:

From the **yellow** conduit,

- a. BLACK wire to cavity 1
- b. WHITE wire to cavity 2
- c. RED wire to cavity 3

From the **black** conduit,

- a. BLACK wire to cavity 4
- b. WHITE wire to cavity 5
- c. RED wire to cavity 6

9. **For ALL Kits:** Connect the six-way black Molex pin housing from the Twist Grip Sensor to the black six-way socket housing inside the fairing.

For handlebars with INTERNAL handlebar-switch wiring only:

FLHR/C models: Position the rubber sleeve installed in Step 7 in the area of the radio or storage box. The sleeve will be moved to the proper location at final assembly.

FLTR models: Position the rubber sleeve installed in Step 7 to prevent chafing of the twist grip sensor wires inside the nacelle.

CAUTION

Improperly aligned handlebars can contact the fuel tank when turned to the left or right. Contact with the fuel tank can cause cosmetic damage. (00372a)

10. Slowly turn the front wheel to the full right fork stop and then the full left fork stop to be sure the handlebar does not contact the fuel tank. If contact occurs and the handlebars are properly centered, raise the handlebar angle as necessary until proper clearance is attained.

NOTE

The upper handlebar-clamp screws MUST be final-tightened in the following sequence to make sure proper clamping is achieved.

11. See Figure 4. Tighten the upper handlebar-clamp screws as follows:

- a. Tighten the left-side front screw (1) until the left side of the handlebar clamp makes contact with the front of the left-side handlebar riser.
- b. Tighten the right-side front screw (2) until the right side of the handlebar clamp makes contact with the front of the right-side handlebar riser.
- c. Tighten the left-side front screw (3) to 16-20 ft-lbs (21.7-27.1 Nm).
- d. Tighten the right-side front screw (4) to 16-20 ft-lbs (21.7-27.1 Nm).
- e. Tighten the right-side rear screw (5) to 16-20 ft-lbs (21.7-27.1 Nm).
- f. Tighten the left-side rear screw (6) to 16-20 ft-lbs (21.7-27.1 Nm).

NOTE

There will be a slight gap between the upper clamp and the risers toward the rear of the handlebar after tightening.

12. Install a new (purchased separately) or original handlebar grip on the left end of the new handlebar according to the handlebar grip instruction sheet or LEFT HAND GRIP, INSTALLATION instructions in the Service Manual.

For vehicles equipped with EXTERNAL handlebar-switch wiring and heated hand grips: Install the heated grip to the new handlebar per the instructions included with the grips.

13. Adjust the positions of the switch housing and the clutch lever assembly on the handlebar for rider comfort.
14. Use a T27 TORX drive head to tighten first the top, then the bottom clutch-lever clamp screws to 72-108 **in-lbs** (8.1-12.2 Nm).
15. Use a T25 TORX drive head to tighten first the lower, then the upper **switch housing** screws to 35-45 **in-lbs** (4.0-5.1 Nm).

NOTES

If the handlebar grips are patterned, align the pattern on the right grip with the pattern on the left grip while the throttle is in the fully closed position.

For vehicles equipped with EXTERNAL handlebar-switch wiring and heated hand grips: Install the heated grip to the new handlebar per the instructions included with the grips.

16. Refer to RIGHT HANDLEBAR CONTROL: INSTALLATION in the Service Manual, and follow the instructions given to install the new (purchased separately) or original right grip/throttle sleeve.
17. Adjust the position of the switch housing and the brake lever assembly on the handlebar for rider comfort. The brake master cylinder must be horizontally level.

NOTE

*Tighten the top **brake lever clamp** screw before tightening the bottom screw.*

18. Use a T27 TORX drive head to tighten first the top, then the bottom brake-lever clamp screws to 72-108 **in-lbs** (8.1-12.2 Nm).

NOTE

Tighten the lower switch housing screw before tightening the upper screw. This will leave any gap in the switch housing at the front for best appearance.

19. Use a T25 TORX drive head to tighten first the lower, then the upper **switch housing** screws to 35-45 **in-lbs** (4.0-5.1 Nm).
20. Verify that the right grip/throttle sleeve rotates and returns freely and does not bind on the handlebar or switch housing.

FINAL ASSEMBLY

1. **For FLTR models:** Proceed to Step 8.
For FLHR/C models: To avoid possible damage to the brake hose, verify that the trim strips remain installed on the inside edges of the headlamp nacelle. Replace the strips if missing, cracked or damaged.
2. See Figure 5.
For North America: Obtain the handlebar clamp cover (D) and the two **flat head** Phillips screws (B, saved earlier).
For Australia, Brazil, England, Europe and Japan: Obtain the handlebar clamp cover (D, saved earlier) and two **new** screws (B, Part Number 2935A, purchased separately).
3. Position the cover onto the flange at the top of the headlamp nacelle. Install the two screws (B) to secure the handlebar clamp cover to the fork lock mechanism.
For North America: Tighten the flat head Phillips screws to 10-20 **in-lbs** (1.1-2.3 Nm).
For Australia, Brazil, England, Europe and Japan: Tighten the special T-27 TORX® screws until the break-away heads snap off.
4. Press the original fork-lock label plate (A) into position on the handlebar cover.
5. Obtain the **pan head** Phillips screw, nut and flat washer removed earlier.
Insert the screw (C) through the hole at the front of the handlebar cover and the top of the headlamp nacelle.
Reach inside the nacelle and install the nut and flat washer onto the screw threads. Tighten the screw to 10-20 **in-lbs** (1.1-2.3 Nm).
6. Obtain the nacelle trim strip and serrated flange nut removed earlier. Insert the hook on the trim strip into the

slot on the handlebar cover. Insert the weld stud on the trim strip into the hole at the top of the headlamp nacelle, and reach inside the nacelle to install the flange nut. Tighten the nut to 15-20 **in-lbs** (1.7-2.3 Nm).

7. Install the headlight into the nacelle. See HEADLAMP ASSEMBLY; INSTALLATION in the Service Manual. Continue after Step 9.
8. **For FLTR models equipped with INTERNAL handlebar-switch wiring only:** Position the PVC tubing on the twist grip sensor wires (installed in **New Handlebar Installation**, Step 7) to prevent chafing of the twist grip sensor wires against the sharp edges inside the fairing, such as the heat sink fins on the radio (if so equipped) or the sharp edges of the radio or storage box mounting bracket.
9. Refer to INSTRUMENT NACELLE: FLTR: INSTALLATION in the Service Manual, and follow the instructions to install the instrument nacelle and bezel.
See UPPER FAIRING AND WINDSHIELD: FLTR: OUTER FAIRING: INSTALLATION in the Service Manual, and install the outer fairing.

For ALL models:

WARNING

Replace brake line gaskets. Re-using original gaskets can cause brake failure and loss of vehicle control, which could result in death or serious injury. (00318a)

CAUTION

Avoid leakage. Be sure gaskets, banjo bolt(s), brake line and caliper bore are clean and undamaged before assembly. (00321a)

10. Carefully inspect the new (sold separately) or existing front brake line or lines for damage or defects, and replace if damaged. Install per FRONT BRAKE MASTER CYLINDER: FRONT BRAKE LINE, INSTALLATION in the Service Manual or the instructions included with the brake lines.
11. Bleed the brakes. See BLEEDING HYDRAULIC BRAKES in the Service Manual.
12. Re-install the clutch cable to the clutch lever or install a **new** clutch cable (sold separately) per the CLUTCH CABLE: INSTALLATION instructions in the Service Manual.

SAFETY CHECK

⚠ WARNING

Be sure that steering is smooth and free without interference. Interference with steering could result in loss of vehicle control and death or serious injury. (00371a)

- Be sure wires, clutch cables and brake lines do not pull tight when handlebars are turned fully to left or right fork stops.

⚠ WARNING

Connect positive (+) battery cable first. If positive (+) cable should contact ground with negative (-) cable connected, the resulting sparks can cause a battery explosion, which could result in death or serious injury. (00068a)

1. Verify that the Ignition/Light Key Switch is turned to the OFF position.

Apply a light coat of petroleum jelly or corrosion retardant material to the battery terminals. Refer to the Service Manual and follow the instructions given to re-attach the battery cables (positive cable first).

⚠ WARNING

Be sure that all lights and switches operate properly before operating motorcycle. Low visibility of rider can result in death or serious injury. (00316a)

2. Turn the Ignition/Light Key Switch to IGNITION, but do not start the motorcycle. Test each handlebar switch for proper operation.

3. Turn the handlebar to the left and right steering stops, testing the handlebar control functions at each stop.
4. Apply the front brake hand lever to test operation of the brake lamp.
5. Refer to the Service Manual, and follow instructions to install the seat.

⚠ WARNING

After installing seat, pull upward on seat to be sure it is locked in position. While riding, a loose seat can shift causing loss of control, which could result in death or serious injury. (00070b)

⚠ WARNING

Before starting engine, be sure throttle control will snap back to idle position when released. A throttle control that prevents engine from automatically returning to idle can lead to loss of control, which could result in death or serious injury. (00390a)

⚠ WARNING

After repairing the brake system, test brakes at low speed. If brakes are not operating properly, testing at high speeds can cause loss of control, which could result in death or serious injury. (00289a)

SERVICE PARTS

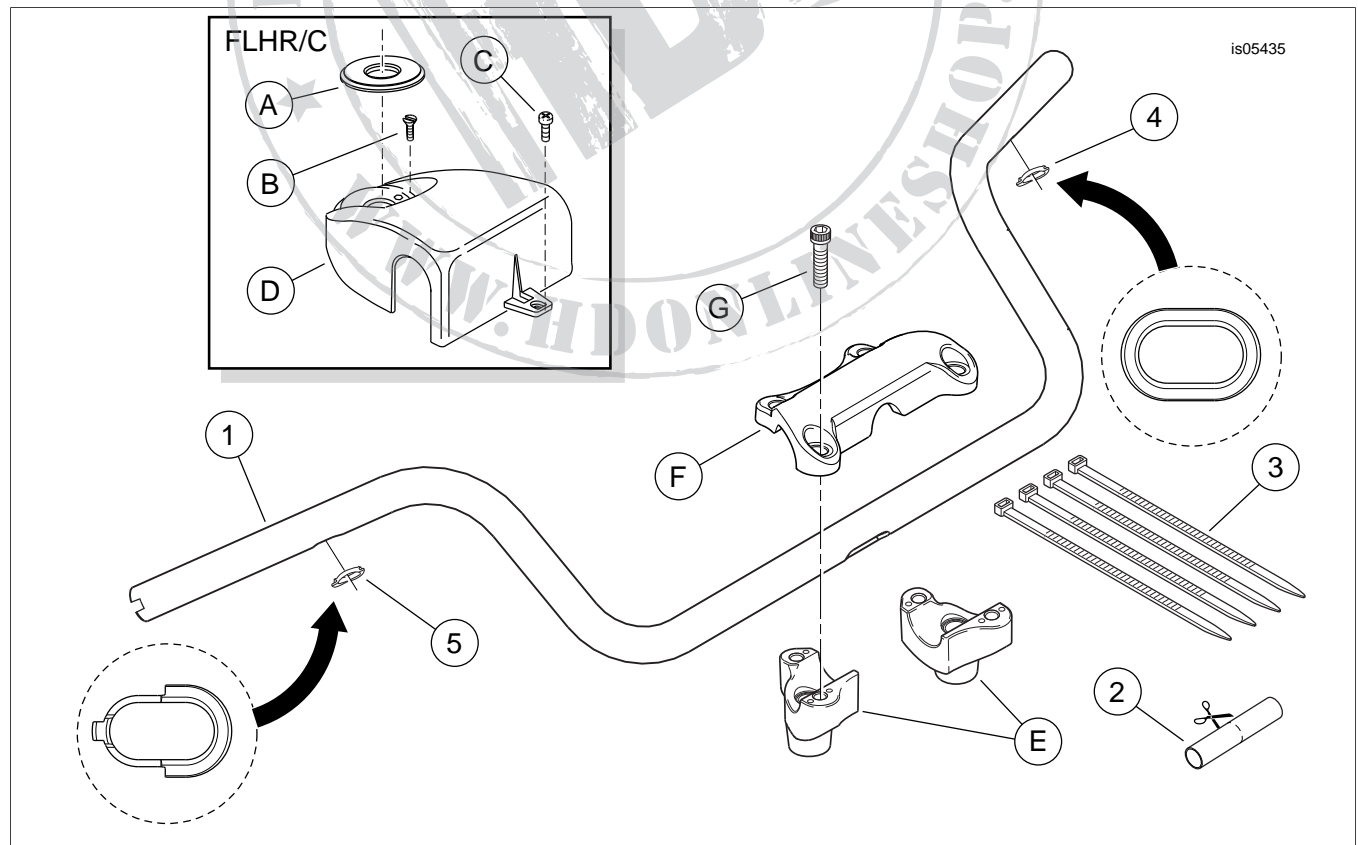

Figure 5. Service Parts, Handlebar Kits

SERVICE PARTS

Table 1. Service Parts, Handlebar Kits

Kit	Item	Description (Quantity)	Part Number
Kit 56166-08 Reduced Reach	1	Handlebar	Not sold separately
	2	Sleeve, rubber (used for externally-wired handlebar only)	Not sold separately
	3	Cable strap (4)	10065
Kit 56180-08 High Pullback	1	Handlebar	Not sold separately
	2	Sleeve, rubber (used for externally-wired handlebar only)	Not sold separately
	3	Cable strap (4)	10065
Kit 56941-09 FLTRSE3 style	1	Handlebar	Not sold separately
	3	Cable strap (4)	10065
	4	Handlebar grommet, left side (with full flange)	11403A
	5	Handlebar grommet, right side (with partial flange)	11642
Items mentioned in text, but not included in kit:			
	A	Original equipment fork-lock plate (FLHR/C models only)	
	B	Original equipment Phillips flat head screws (2, for North America FLHR/C) Break-away flat head TORX screws (2, for Australia, Brazil, England, Europe and Japan FLHR/C models only)	2933 2935A
	C	Original equipment Phillips pan head screw (FLHR/C models only)	
	D	Original equipment handlebar cover (FLHR/C models only)	
	E	Original equipment handlebar riser (2)	
	F	Original equipment upper handlebar clamp	
	G	Original equipment handlebar clamp screw (4)	

Table 2. Service Parts, Twist Grip Sensor Kit (Part Number 32310-08)

Item	Description (Quantity)	Part Number
1	Sensor, twist grip (for internally-wired handlebars)	Not sold separately
2	Pin housing, six-way	72188-07BK
3	Retainer, T-stud	73212-07
4	Cable strap	10006
5	PVC tubing	Not sold separately