



# INSTRUCTIONS

-J00600

REV. 12-06-2000

Kit Number 56060-01

## SKULL BILLET HANDLEBAR CLAMP

### General

This kit fits 1984 and later FLST, FLSTC, FLSTF, FLSTN, FXST, FXSTC, FXSTB, 1993 and later FXDWG. This kit contains the following components:

QTY	DESCRIPTION
1	Handlebar clamp, upper

### Installation

#### NOTE

Be aware of any spacers that may be located between handlebar risers and handlebar clamp on early 1991 and earlier vehicles. Be sure to reinstall these spacers in their original location.

1. Remove hardware securing existing upper handlebar clamp, making note of the hardware, as it will need to be used in the same location to install new clamp.

#### CAUTION

Do not allow gauges or handlebars to fall against or scratch other chassis components.

2. Replace old clamp with new custom clamp and secure using hardware removed in Step 1.
3. Tighten two rear mounting screws until clamp halves contact. Do not tighten completely.

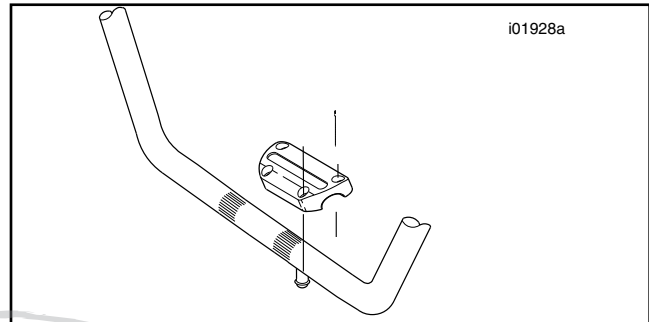

Figure 1. Install new handlebar clamp with existing hardware

4. Torque front screws to 12-15 ft-lbs.
5. Torque rear screws to 12-15 ft-lbs.

#### NOTE

When installation is complete, upper and lower clamps should touch in rear and have a slight gap in front.

#### NOTE

For some older motorcycles with gauges mounted on the handlebars, it may be necessary to relocate gauge support bracket on top of upper clamp, instead of between clamp halves. This will require two spacers, Part No. HD-5736, and two longer mounting screws, Part No. HD-853.

