



INSTRUCTIONS

-J02887

REV. 2006-07-28

SWINGBACK HANDLEBAR KIT

GENERAL

Kit Number

56039-03A

Models

Ask a Harley-Davidson dealer or refer to the latest Harley-Davidson Genuine Motor Accessories and Genuine Motor Parts catalog to determine if this handlebar can be installed on your motorcycle.

This kit does not fit models equipped with Heated Hand Grips, Softail Nacelle Kit (Part Number 67907-96), Hydraulic Clutch Kits, handlebar mounted gauges or the Road Tech® Radio.

Additional Parts or Accessories Required

Separate purchase of additional parts or accessories may be required for proper installation of this handlebar kit on your model motorcycle. Refer to the latest Harley-Davidson Genuine Motor Accessories and Genuine Motor Parts catalog for a list of required parts or accessories for your model.

Loctite® 271 (Red) Threadlocker and Sealant (H-D Part Number 99671-97) is required for the proper installation of this kit.

Fresh, uncontaminated brake fluid will also be needed. Refer to your Owner's Manual or the Service Manual for this year and model motorcycle to determine the correct brake fluid for this vehicle.

Motorcycles equipped with a **glued** left-side hand grip will also require a new grip, sold separately. Refer to the Parts Catalog for replacement stock hand grips.

Ask a Harley-Davidson dealer about the selection of Genuine Motor Accessory hand grips that are available.

⚠ WARNING

The rider's safety depends upon the correct installation of this kit. Use the appropriate service manual procedures. If the procedure is not within your capabilities or you do not have the correct tools, have a Harley-Davidson dealer perform the installation. Improper installation of this kit could result in death or serious injury. (00333a)

NOTE

This instruction sheet references Service Manual information. A Service Manual for your model motorcycle is required for this installation and is available from a Harley-Davidson Dealer.

Kit Contents

See Figure 4 and Table 1.

INSTALLATION

Preparation

⚠ WARNING

To prevent accidental vehicle start-up, which could cause death or serious injury, disconnect battery cables (negative (-) cable first) before proceeding. (00307a)

⚠ WARNING

Disconnect negative (-) battery cable first. If positive (+) cable should contact ground with negative (-) cable connected, the resulting sparks can cause a battery explosion, which could result in death or serious injury. (00049a)

1. Refer to the Service Manual and follow the instructions to remove the seat and disconnect the battery cables, negative cable first. Retain all seat mounting hardware.

⚠ WARNING

When servicing the fuel system, do not smoke or allow open flame or sparks in the vicinity. Gasoline is extremely flammable and highly explosive, which could result in death or serious injury. (00330a)

2. Loosen the fuel tank. Refer to FUEL TANK REMOVAL in the appropriate section (Carbureted or EFI Engine) of the Service Manual.

⚠ CAUTION

Direct contact of D.O.T. 5 brake fluid with eyes can cause eye irritation, swelling, and redness. Avoid eye contact. In case of eye contact flush with large amounts of water and get medical attention. Swallowing large amounts of D.O.T. 5 brake fluid can cause digestive discomfort. If swallowed, obtain medical attention. Use in well ventilated area. KEEP OUT OF REACH OF CHILDREN. (00144a)

⚠ CAUTION

Direct contact of D.O.T. 4 brake fluid with eyes can cause irritation. Avoid eye contact. In case of eye contact flush with large amounts of water and get medical attention. Swallowing large amounts of D.O.T. 4 brake fluid can cause digestive discomfort. If swallowed, obtain medical attention. Use in well ventilated area. KEEP OUT OF REACH OF CHILDREN. (00240a)

CAUTION

D.O.T. 4 brake fluid will damage painted and body panel surfaces if it comes in contact with. Always use caution and protect surfaces from spills whenever brake work is performed. Failure to comply can result in cosmetic damage. (00239b)

- If D.O.T. 4 brake fluid contacts painted surfaces, flush IMMEDIATELY with clear water.

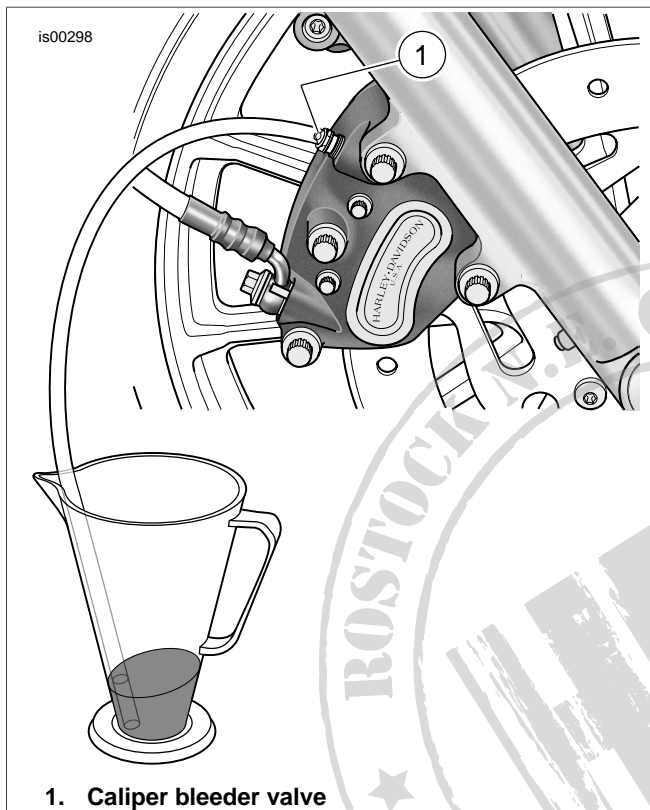

1. Caliper bleeder valve

Figure 1. Draining Brake Fluid

3. Bleed the brake fluid from the front brake.
See Figure 1. Open the bleeder nipple cap on the front brake caliper. Obtain a length of plastic tubing. Install one end of the tubing over the caliper bleeder valve. Place the free end of the tubing into a suitable container.
4. Open the bleeder valve about one-half turn and pump the front-brake hand lever to drain the fluid out of the front brake system. Do not re-use brake fluid.

Original Handlebar Removal

NOTE

Cover the front fender and the front of the fuel tank with clean shop towels to prevent scratching. Damage to the finish could result.

CAUTION

Remove brake line components carefully. Damage to seating surfaces can cause leakage. (00320a)

1. Carefully make note of the front brake line routing and the orientation of the banjo fittings. Disconnect the brake line from the front brake caliper and the front brake master

cylinder assembly. Save the banjo bolts, but discard the two brake-line gaskets found at each banjo fitting. See FRONT BRAKE MASTER CYLINDER in the Service Manual.

2. Remove the old brake line from the motorcycle.

NOTE

For models with handlebar-mounted turn signals, remove the plastic wiring retainer clips that secure the turn signal harnesses to the handlebar.

3. Using a T27 TORX® drive head, remove the front-brake master cylinder and clutch-lever assemblies from the handlebar.
4. Refer to CLUTCH HAND CONTROL: REMOVAL in the Service Manual, and follow the instructions to disconnect the clutch cable from the clutch lever.

If the clutch cable is being replaced, disconnect the clutch cable from the side cover, and remove the cable from the vehicle.

NOTE

Molex connectors are used for the handlebar control wiring on 2007 and later models. 2006 and earlier vehicles use Deutsch connectors. Refer to the MOLEX ELECTRICAL CONNECTORS or DEUTSCH ELECTRICAL CONNECTORS section of the Service Manual for disconnection and re-connection procedures.

Before disconnecting the handlebar control wiring, note the wire routing.

5. Disconnect the handlebar control wiring from the gray and black 6-way main harness connectors under the fuel tank.

NOTE

Before disconnecting the turn signal wiring, note turn signal wire routing.

6. For vehicles with handlebar-mounted turn signals, separate the 6-way turn signal connector halves.
7. Refer to HANDLEBAR SWITCHES: RIGHT HANDLEBAR CONTROLS section of the Service Manual for removal of the right-side switch housing assembly and harness. This is necessary to access the throttle cables.
8. Refer to the THROTTLE CONTROL section of the Service Manual to disconnect the throttle cables from the existing right grip/ throttle sleeve assembly.
9. Refer to the LEFT HANDLEBAR CONTROLS section of the Service Manual for removal of the left-side switch housing assembly and wire harness.
10. See Figure 2. Remove and discard the screws (1) that fasten the handlebar upper clamps (2) to the risers (3). Discard the clamps. Remove the handlebar (4) from the motorcycle.
11. If the left-side hand grip is not glued to the handlebar: Remove the hand grip and set it aside for installation to the new handlebar.

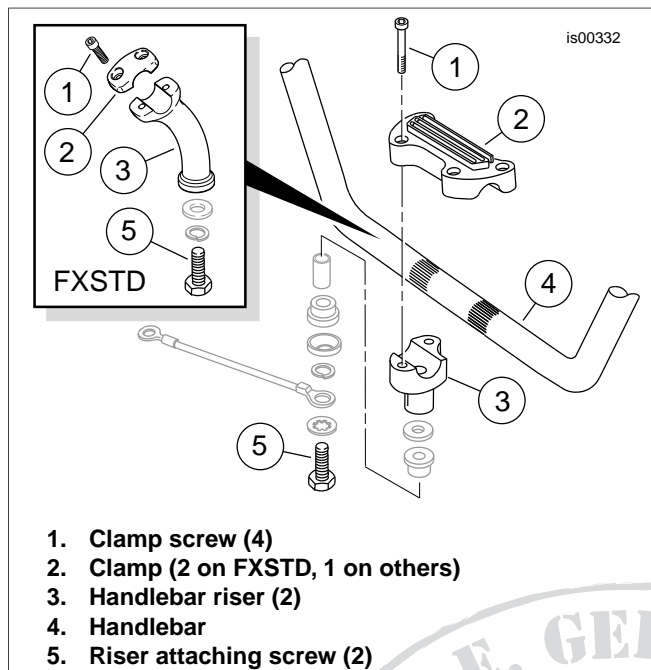

Figure 2. Handlebar Clamps and Risers

NOTE

Make note of the installed sequence of the riser attaching hardware to ensure correct re-assembly.

12. Remove and discard the stock handlebar risers. Save the remaining hardware for later installation.

NOTES

2007 and later models use Molex connectors. 2006 and earlier vehicles use Deutsch connectors. Refer to MOLEX or DEUTSCH ELECTRICAL CONNECTORS in the Service Manual for terminal removal and re-installation procedures.

DO NOT remove the wires from the Molex or Deutsch handlebar switch connector **pin housings** under the fuel tank.

Models with handlebar-mounted turn signals: DO NOT remove the wires from the Multilock connector **pin housing** under the fuel tank.

13. Note the wire colors and positions in each cavity of the **socket housings** leading from the switches. Refer to the wiring diagram and the ELECTRICAL CONNECTORS section in the Service Manual. Remove the wires from the socket housings.

Models with handlebar-mounted turn signals: Note the wire colors and positions in each cavity of the Multilock **socket housing** leading from the turn signals. Refer to the wiring diagram and the AMP MULTILOCK ELECTRICAL CONNECTORS section in the Service Manual. Remove the wires from the socket housing.

14. Use tape to wrap the wire terminal ends **from each source** to make separate leaders. Wrap each leader tight enough to enter the grommet hole and pass easily through the **new** handlebar.

New Handlebar Wiring

1. Remove the plastic wiring retainer clips that secured both switch harnesses to the original handlebar.

2. See Figure 4. Slide one large grommet (2) onto each of the switch-wire bundles, positioning the grommet close to the switch end.

3. **For models WITHOUT handlebar-mounted turn signals,** proceed to Step 8.

For 2006 and later FXDB and FXDWG models, proceed to Step 4.

For models WITH handlebar-mounted turn signals, EXCEPT 2006 and later FXDB and FXDWG models, slide one small grommet (3) onto each of the turn-signal wire bundles, positioning the grommet close to the turn signal end.

4. Apply a light coat of liquid soap, window cleaner, or all-purpose lubricant such as WD-40®, to the right-side turn signal wire bundle.

5. **For 2006 and later FXDB and FXDWG models:** Gently feed the right-side turn-signal wire leader into the small round grommet on the underside of the right-side lower switch housing. Repeat Steps 4 and 5 for the left-side turn signal wires, then proceed to Step 8.

For all other models: Gently feed the right-side turn-signal wire leader into the small round grommet hole near the right-side end of the new handlebar and toward the center of the bar.

WARNING

Carefully pull the wires through hole in handlebar to prevent stripping the wires. Stripped wires can cause short circuits and damage vehicle electrical components, which could cause loss of vehicle control resulting in death or serious injury. (00418b)

6. Pull the taped end of the wire bundle through the wire-exit hole in the riser.
7. Repeat Steps 4 through 6 for the left-side turn signal wires.
8. Apply a light coat of liquid soap, window cleaner, or all-purpose lubricant to the right-side switch wire bundle.

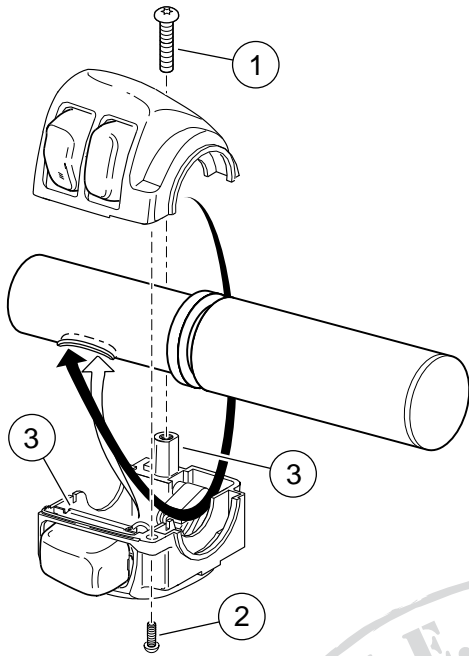

1. Upper switch housing screw
2. Lower switch housing screw
3. Pinch points

Figure 3. Switch-Housing Wire Routing (Right-Side Housing Shown)

WARNING

Wiring in the switch housings must be routed exactly as shown. Pinch points in the switch housings can short-circuit or sever wires, which could cause loss of control resulting in death or serious injury. (00415b)

9. See Figure 3.

For 2006 and later FXDB and FXDWG models: Route the switch wire and turn signal wire bundles through the switch housing as shown. Gently feed the wire bundles into the oblong switch wire hole near the right-side end of the handlebar, and toward the center of the bar.

For all other models: Route the switch wire bundle through the switch housing as shown. Gently feed the wire bundle into the oblong switch wire hole near the right-side end of the handlebar, and toward the center of the bar.

10. Pull the taped end of the wire bundle through the wire-exit hole at the center of the handlebar.

11. Repeat Steps 8 through 10 for the left-side handlebar switch wires.

WARNING

Grommets in each of the wiring holes in the handlebar must remain in position after routing the wiring through the handlebar. Operation without the grommets in place can damage wires, causing a short circuit which could result in death or serious injury. (00416d)

12. See Figure 4. Insert the switch-wire grommets (2) into place in the switch-wire holes in the handlebar.

NOTE

The round turn-signal wiring grommets are an extremely tight fit. Use a twisting motion to avoid damaging the grommets.

13. **For models WITH handlebar-mounted turn signals, EXCEPT 2006 and later FXDB and FXDWG models,:** Insert the turn-signal grommets (3) into place in the turn-signal wire holes in the handlebar.
14. Slide one large grommet (2) onto the wire bundles coming from each riser wire hole, and insert the grommet into place in the hole.
15. Loosely fasten the brake-lever and clutch-lever clamps to the new handlebar.
16. Loosely fasten the handlebar-switch housings to the new handlebar.
17. Remove the tape from the ends of the wire bundles.
18. Check for electrical continuity between the handlebar and each wire in the wire bundles. Continuity would indicate a short circuit, which would require examination of the wires and routing in the switch housing.

New Handlebar Installation

1. Apply two drops of Loctite® 271 (Red) Threadlocker and Sealant to the threads of each riser bolt (saved earlier).

For FXSTD models only: Install spacers (B, purchased separately) into the bores in the upper fork bracket (triple clamp).

For ALL models: Install the new handlebar onto the upper fork bracket using the saved hardware in the same sequence as removed. Tighten the riser bolts to 25-30 ft-lbs (34-41 Nm).

2. Route the switch wire bundles down through the large oval opening in the upper fork bracket.
3. Follow the routing noted in the disassembly steps (left switch wire bundle to left side of frame; right switch wire bundle to right side of frame) until the wires reach the switch-wire pin housings. Install any clips or wire guides saved in disassembly.

NOTE

Molex connectors are used for the handlebar control wiring on 2007 and later models. 2006 and earlier vehicles use Deutsch connectors. Refer to the MOLEX ELECTRICAL CONNECTORS or DEUTSCH ELECTRICAL CONNECTORS section of the Service Manual for re-connection procedures.

4. Refer to the notes made during the removal steps, and the wiring diagram and correct ELECTRICAL CONNECTORS section in the Service Manual. Insert each socket terminal from the left-side wire bundle into the correct cavity of the **gray** socket housing removed earlier.
5. Insert each socket terminal from the right-side wire bundle into the correct cavity of the **black** socket housing removed earlier.

NOTE

Some models require installation of switch wire or turn-signal wire extensions in order to reach the vehicle harness pin housings under the fuel tank. Refer to the latest Harley-Davidson Genuine Motor Accessories and Genuine Motor Parts catalog for a list of required parts or accessories for your model.

6. Connect the gray socket housing to the gray 6-way pin housing under the left side of the fuel tank. Connect the black socket housing to the black 6-way pin housing under the right side of the tank.
7. **For models with handlebar-mounted turn signals:**
 - a. Route both turn signal wires down through the large oval opening in the center of the upper fork bracket.
 - b. Follow the routing noted earlier to the 6-way turn signal pin housing under the right side of the fuel tank.
 - c. Refer to the notes made during the removal steps, and the wiring diagram and AMP MULTILOCK ELECTRICAL CONNECTORS section in the Service Manual. Insert each socket terminal leading from the turn signals into the correct cavity of the Multilock socket housing removed earlier.
 - d. Install the clips and/ or wire guides saved earlier.
8. Connect the 6-way AMP socket housing to the main harness pin housing under the fuel tank.

WARNING

When servicing the fuel system, do not smoke or allow open flame or sparks in the vicinity. Gasoline is extremely flammable and highly explosive, which could result in death or serious injury. (00330a)

9. Re-install the fuel tank. Refer to FUEL TANK-INSTALLATION in the appropriate section (Carbureted or EFI Engine) of the Service Manual.
10. Refer to RIGHT HANDLEBAR SWITCH: INSTALLATION in the Service Manual, and follow the instructions given to install the throttle control cables and a new (purchased separately) or original right grip/ throttle sleeve assembly.
11. Adjust the position of the switch housing and the brake lever assembly on the handlebar for rider comfort and posture. The brake master cylinder must be horizontally level.

NOTE

*Tighten the top **brake lever clamp** screw before tightening the bottom screw.*

12. Use a T27 TORX drive head to tighten first the top, then the bottom brake-lever clamp screws to 71-80 **in-lbs** (8.0-9.0 Nm).

NOTE

Tighten the lower switch housing screw before tightening the upper screw. This will leave any gap in the switch housing at the front for best appearance.

13. Use a T25 TORX drive head to tighten first the lower, then the upper **switch housing** screws to 35-45 **in-lbs** (4.0-5.1 Nm).
14. Verify that the right grip/ throttle sleeve rotates and returns freely and does not bind on the handlebar or switch housing.

NOTE

If the handlebar grips are patterned, align the pattern on the left grip with the pattern on the right grip while the throttle is in the fully closed position.

15. Install a new (purchased separately) or original handlebar grip on the left end of the new handlebar according to the handlebar grip instruction sheet or the LEFT HAND GRIP, INSTALLATION instructions in the Service Manual.
16. Refer to LEFT HANDLEBAR SWITCH: INSTALLATION in the Service Manual. Adjust the positions of the switch housing and the clutch lever assembly on the handlebar for rider comfort and posture.
17. Use a T27 TORX drive head to tighten first the top, then the bottom clutch-lever clamp screws to 71-80 **in-lbs** (8.0-9.0 Nm).
18. Use a T25 TORX drive head to tighten first the lower, then the upper **switch housing** screws to 35-45 **in-lbs** (4.0-5.1 Nm).

FINAL ASSEMBLY

WARNING

Replace brake line gaskets. Re-using original gaskets can cause brake failure and loss of vehicle control, which could result in death or serious injury. (00318a)

CAUTION

Avoid leakage. Be sure gaskets, banjo bolt(s), brake line and caliper bore are clean and undamaged before assembly. (00321a)

1. Carefully inspect the brake line for damage or defects, and replace the brake line if damaged. Install the brake line per the Service Manual instructions or the instructions included with the Brake Line Kit.
2. Bleed the brakes. See BLEEDING HYDRAULIC BRAKES in the Service Manual.
3. Re-install the clutch cable to the clutch lever or install a **new** clutch cable (sold separately) per the CLUTCH HAND CONTROL instructions in the Service Manual.

SAFETY CHECK

WARNING

Be sure that steering is smooth and free without interference. Interference with steering could result in loss of vehicle control and death or serious injury. (00371a)

- **Be sure wires, clutch cables, throttle/ idle cables and brake lines do not pull tight when handlebars are turned fully to left or right fork stops.**

WARNING

Connect positive (+) battery cable first. If positive (+) cable should contact ground with negative (-) cable connected, the resulting sparks can cause a battery explosion, which could result in death or serious injury. (00068a)

1. Verify that the Ignition/ Light Key Switch is turned to the OFF position.

Apply a light coat of petroleum jelly or corrosion retardant material to the battery terminals. Refer to the Service Manual and follow the instructions given to re-attach the battery cables (positive cable first).

⚠ WARNING

Be sure that all lights and switches operate properly before operating motorcycle. Low visibility of rider can result in death or serious injury. (00316a)

2. Turn the Ignition/Light Key Switch to IGNITION, but do not start the motorcycle. Test each handlebar switch for proper operation.
3. For 2005 and earlier FXDWG models:

⚠ WARNING

Be sure plug in lower forward section of rear fender is installed. Operation without plug installed could allow tire contact with wiring harness. Tire contact with wiring harness can cause wire damage, which could result in death or serious injury. (00456b)

- Inspect the lower forward section of the fender inside the rear wheel well. A three-inch (76 mm) square hole in the fender should be covered with a rubber plug.
- If the plug is damaged, loose or missing, it **MUST** be replaced (Part Number 59150-90, available from a Harley-Davidson dealer). Without this plug in place, the wire harness could come out of the opening and contact the rear tire, causing rear lighting failure or other serious electrical problems.

4. **For ALL models:** Turn the handlebar to the left and right steering stops, testing the handlebar control functions at each stop.
5. Apply the front brake hand lever to test operation of the brake lamp.
6. Refer to the Service Manual, and follow instructions to install the seat.

⚠ WARNING

After installing seat, pull upward on seat to be sure it is locked in position. While riding, a loose seat can shift causing loss of control, which could result in death or serious injury. (00070b)

⚠ WARNING

Before starting engine, be sure throttle control will snap back to idle position when released. A throttle control that prevents engine from automatically returning to idle can lead to loss of control, which could result in death or serious injury. (00390a)

⚠ WARNING

After repairing the brake system, test brakes at low speed. If brakes are not operating properly, testing at high speeds can cause loss of control, which could result in death or serious injury. (00289a)

SERVICE PARTS

is02873

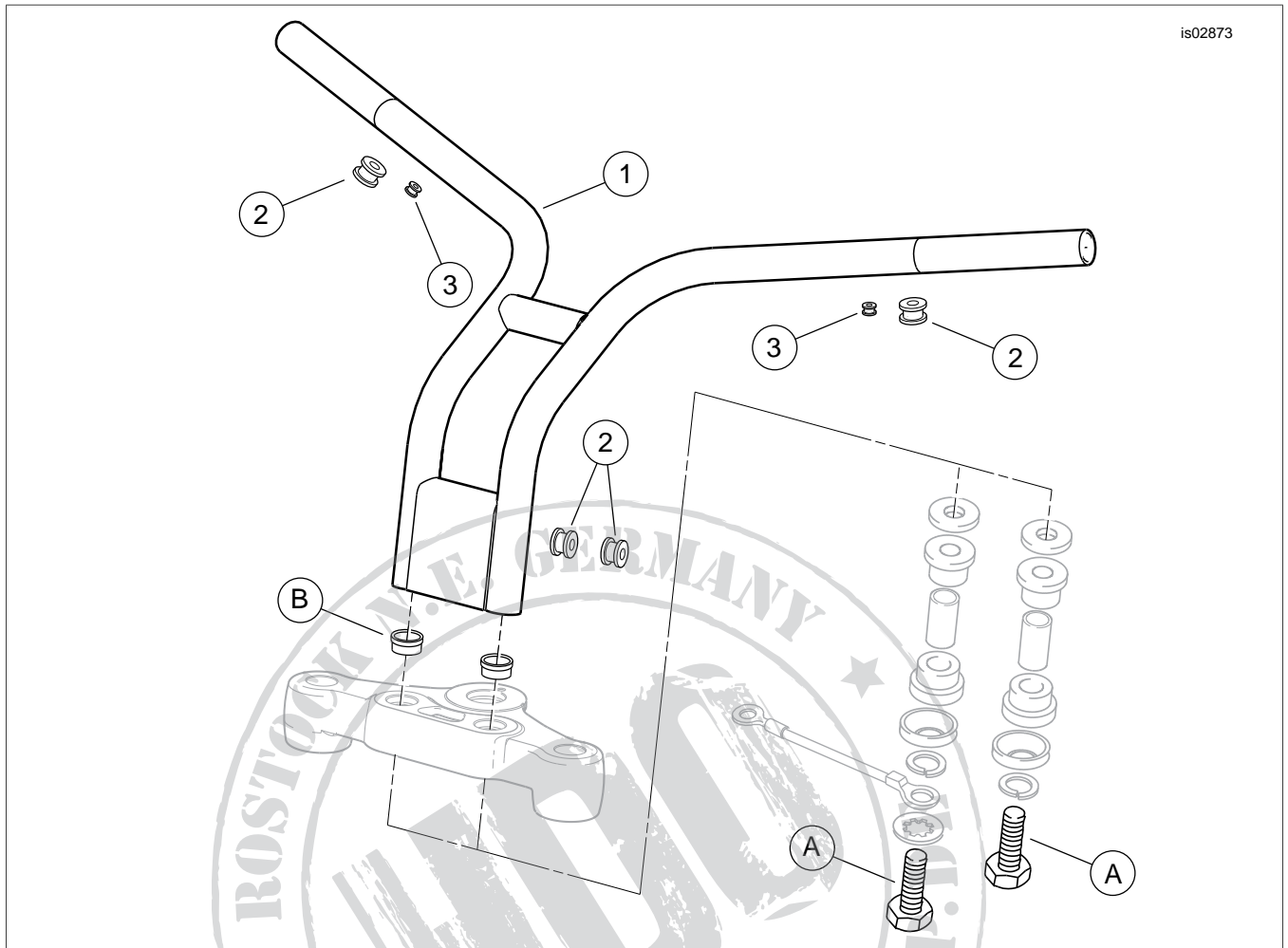

Figure 4. Service Parts

Table 1. Service Parts Table

Item	Description (Quantity)	Part Number
1	Handlebar, Swingback	Not sold separately
2	Handlebar grommet, large (4)	11386
3	Handlebar grommet, small (2)	Not sold separately
Items mentioned in text, but not included in kit:		
A	Original equipment riser mounting bolts (2)	
B	Mount spacer (2, FXSTD models only)	