



INSTRUCTIONS

-J04406

REV. 2008-08-07

STREET SLAMMER HANDLEBAR KIT

GENERAL

Kit Number

55975-08A

Models

For model fitment information, see the P&A Retail Catalog or the Parts and Accessories section of www.harley-davidson.com (English only).

This kit does not fit models equipped with Hydraulic Clutch Kits, handlebar mounted gauges or the Road Tech® Radio or FLHRS models equipped with an accessory windshield.

ABS Models

⚠ WARNING

The rider's safety depends upon the correct installation of this kit. Dealer installation is required for vehicles equipped with ABS brakes. Proper installation of this kit requires the use of special tools available only through a Harley-Davidson Dealer. An improperly serviced brake system can adversely affect brake performance, which could result in death or serious injury. (00578b)

Non-ABS Models

⚠ WARNING

The rider's safety depends upon the correct installation of this kit. Use the appropriate service manual procedures. If the procedure is not within your capabilities or you do not have the correct tools, have a Harley-Davidson dealer perform the installation. Improper installation of this kit could result in death or serious injury. (00333a)

Additional Parts or Accessories Required

Separate purchase of additional parts or accessories is required for proper installation of this Handlebar Kit on your model motorcycle. Please see the P&A Retail Catalog or the Parts and Accessories section of www.harley-davidson.com (English only) for a list of required parts or accessories for your model.

For Australia, Brazil, England, Europe and Japan, two special screws (2935A) will also be required.

Tools and Supplies Required

Loctite® 271 (Red) Threadlocker and Sealant (99671-97) is required for the proper installation of this kit.

Fresh, uncontaminated brake fluid from a sealed container will also be needed. Refer to the owner's manual for the appropriate brake fluid.

⚠ WARNING

Replace brake line gaskets. Re-using original gaskets can cause brake failure and loss of vehicle control, which could result in death or serious injury. (00318a)

For models that re-use the original brake line, the two brake line gaskets found at each banjo fitting **must be replaced**. Refer to the appropriate Parts Catalog or see a Harley-Davidson dealer for the correct part numbers.

Motorcycles equipped with a **glued** left hand grip will also require a new grip, sold separately. Refer to the Parts Catalog for replacement stock hand grips.

Ask a Harley-Davidson dealer about the selection of Genuine Motor Accessory hand grips that are available.

NOTE

This instruction sheet references service manual information. A service manual for your model motorcycle is required for this installation and is available from a Harley-Davidson Dealer.

Kit Contents

See Figure 11 and Table 2.

REMOVAL

Preparation - All Models

⚠ WARNING

To prevent accidental vehicle start-up, which could cause death or serious injury, remove main fuse before proceeding. (00251b)

⚠ WARNING

To prevent accidental vehicle start-up, which could cause death or serious injury, disconnect battery cables (negative (-) cable first) before proceeding. (00307a)

⚠ WARNING

Disconnect negative (-) battery cable first. If positive (+) cable should contact ground with negative (-) cable connected, the resulting sparks can cause a battery explosion, which could result in death or serious injury. (00049a)

1. See the service manual and remove the seat and disconnect battery cables or remove the main fuse. Save the seat hardware for installation.

WARNING

When servicing the fuel system, do not smoke or allow open flame or sparks in the vicinity. Gasoline is extremely flammable and highly explosive, which could result in death or serious injury. (00330a)

2. **Softail and Dyna models:** See the service manual and loosen the fuel tank.

CAUTION

Direct contact of D.O.T. 5 brake fluid with eyes can cause eye irritation, swelling, and redness. Avoid eye contact. In case of eye contact flush with large amounts of water and get medical attention. Swallowing large amounts of D.O.T. 5 brake fluid can cause digestive discomfort. If swallowed, obtain medical attention. Use in well ventilated area. KEEP OUT OF REACH OF CHILDREN. (00144a)

CAUTION

Direct contact of D.O.T. 4 brake fluid with eyes can cause irritation. Avoid eye contact. In case of eye contact flush with large amounts of water and get medical attention. Swallowing large amounts of D.O.T. 4 brake fluid can cause digestive discomfort. If swallowed, obtain medical attention. Use in well ventilated area. KEEP OUT OF REACH OF CHILDREN. (00240a)

CAUTION

D.O.T. 4 brake fluid will damage painted and body panel surfaces it comes in contact with. Always use caution and protect surfaces from spills whenever brake work is performed. Failure to comply can result in cosmetic damage. (00239b)

NOTES

Immediately wipe up any brake fluid spills with a clean, dry, soft cloth. Follow up by thoroughly wiping affected area with a clean, damp, soft cloth (small spills) or washing with a large quantity of soapy water (large spills).

Cover nearby motorcycle surfaces with a polyethylene protective sheet to help protect against damage to finish caused by spilled DOT 4 brake fluid.

3. See the service manual and drain the brake fluid from the front brake reservoir and brake lines.

Handlebar Removal - Dyna and Softail

NOTE

Cover the front fender and the fuel tank with clean shop towels to prevent scratching. Damage to the finish could result.

1. Note the front brake line routing and the orientation of the banjo fittings. See the service manual and disconnect and remove the brake line. Save the banjo bolts, but discard the brake line gaskets.
2. Remove the plastic wiring retainer clips that secure the turn signal harnesses to the handlebar, if equipped.
3. Remove the front brake master cylinder and clutch lever assemblies from the handlebar.

4. See the service manual and disconnect the clutch cable from the clutch lever.

If the clutch cable is being replaced, disconnect the clutch cable from the side cover and remove the cable from the vehicle.

NOTE

2007 and later models use Molex connectors. 2006 and earlier vehicles use Deutsch connectors. See the service manual for disconnection and connection procedures.

Note wire routing before disconnecting the handlebar wiring.

5. Disconnect the handlebar control wiring from the gray and black 6-way main harness connectors under the fuel tank.
6. Separate the 6-way turn signal connector halves.
7. See the service manual and perform the following:
 - a. Remove the right side switch housing assembly and harness to access the throttle/idle cables.
 - b. Disconnect the throttle/idle cables from the existing right hand grip/throttle sleeve assembly or remove them if replacing with new cables.
 - c. Remove the left side switch housing assembly and wire harness.
8. See Figure 1. Remove and discard screws (1), upper clamp (2) and handlebar (4).

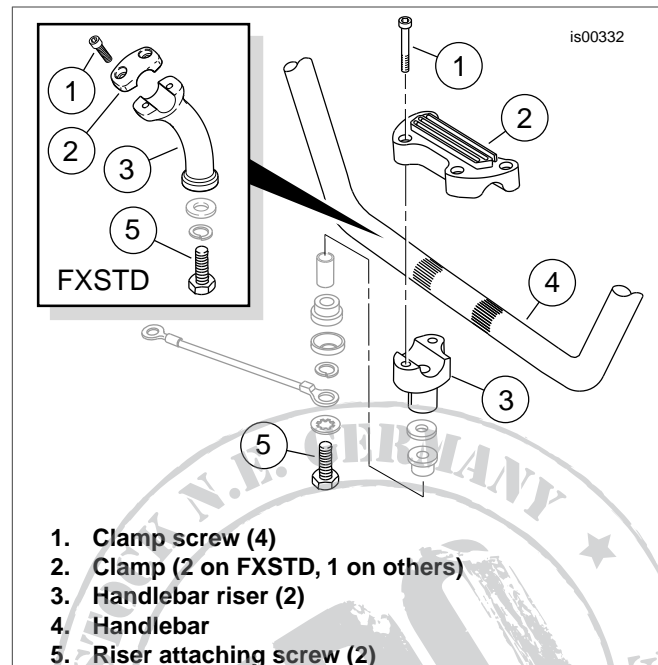

Figure 1. Handlebar Clamps and Risers (Dyna and Softail Models)

9. If the left hand grip is not glued to the handlebar: Remove the hand grip and set it aside for installation to the new handlebar, if desired.

NOTE

Note the sequence of the riser mounting hardware for correct installation.

10. Remove and discard stock handlebar risers. Save hardware for installation as necessary.

NOTES

DO NOT remove the wires from the connector **pin housings** under the fuel tank.

- Note the wire colors and positions in each cavity of the **socket housings** leading from the switches and from the turn signals. See the service manual and remove the wires from the socket housings.
- Use tape to wrap the wire terminal ends **from each source** to make separate leaders. Wrap each leader tightly enough to enter the grommet hole and pass easily through the new handlebar. Proceed to "INSTALLATION".

Handlebar Removal - 2007 and Earlier Touring Models

NOTE

Cover the front fender and the front of the fuel tank with clean shop towels to prevent scratching.

CAUTION

Remove brake line components carefully. Damage to seating surfaces can cause leakage. (00320a)

- Note the front brake line routing and the orientation of the banjo fittings. See the service manual and disconnect and remove the brake line. Save the banjo bolts, but discard the brake line gaskets.
- Remove the plastic wiring retainer clips that secure the turn signal harnesses to the handlebar, if equipped.
- Remove the front brake master cylinder and clutch lever assemblies from the handlebar.
- See the service manual and disconnect the clutch cable from the clutch lever.

If the clutch cable is being replaced: Disconnect the clutch cable from the side cover and remove the cable from the vehicle.

- See the service manual and remove the headlamp assembly from the headlamp nacelle.

NOTE

2007 and later models use Molex connectors. 2006 and earlier vehicles use Deutsch connectors. See the service manual for disconnection and connection procedures.

- Disconnect the handlebar control wiring from the gray and black 6-way main harness connectors inside the headlamp nacelle. Separate the 6-way turn signal connector halves. Disconnect the electronic cruise control wiring from the two 4-way connectors if equipped.
- See the service manual and perform the following:
 - Remove the right side switch housing assembly and harness. This is necessary to access the throttle/idle cables.
 - Disconnect the throttle/idle cables from the existing right grip/throttle sleeve assembly.
 - Remove the left side switch housing assembly and wire harness.

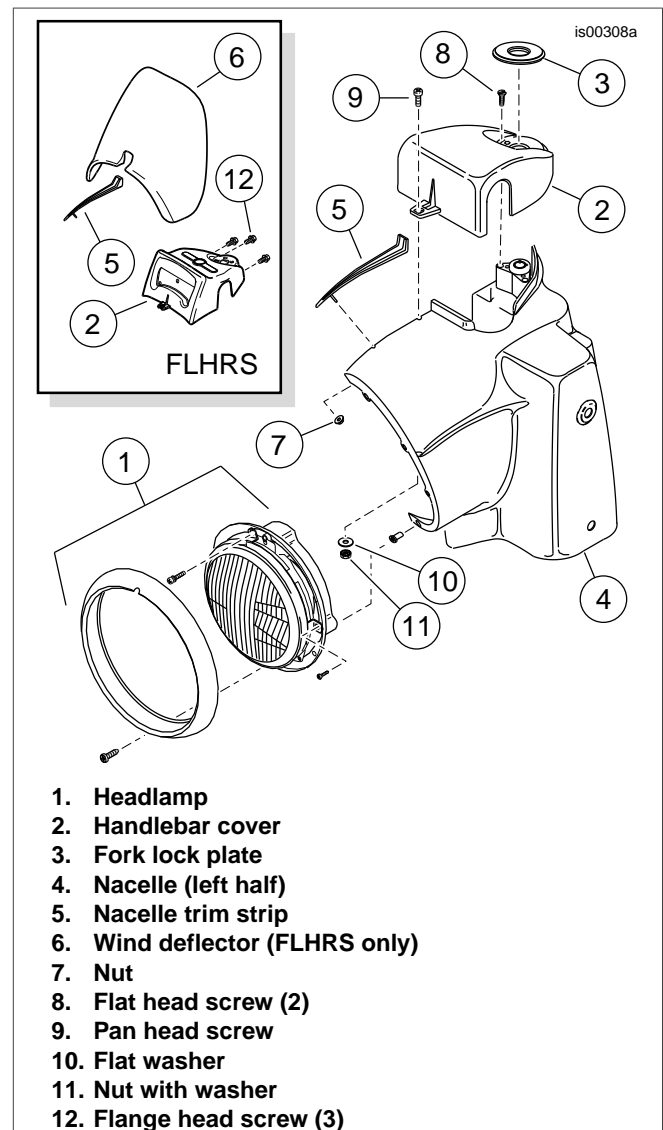

Figure 2. Nacelle, Headlamp and Handlebar Cover (FLHR Shown)

- See the service manual and follow the applicable steps to remove the handlebar cover, wind deflector and handlebar.
- If the left hand grip is not glued to the handlebar:** Remove the hand grip and set it aside for installation to the new handlebar, if desired.

NOTE

Note the sequence of the riser hardware for correct installation of new risers.

- Remove and discard the stock handlebar risers. Save the hardware for installation.

NOTES

2007 and later models use Molex connectors. 2006 and earlier vehicles use Deutsch connectors. See the service manual for terminal removal and installation procedures.

DO NOT remove the wires connector **pin housings** inside the nacelle.

- Note the wire colors and positions in each cavity of the **socket housings** leading from the switches and from the

turn signals. See the service manual and remove the wires from the socket housings.

- Use tape to wrap the wire terminal ends **from each source** to make separate leaders. Wrap each leader tightly enough to enter the grommet hole and pass easily through the **new** handlebar. Proceed to "**INSTALLATION**".

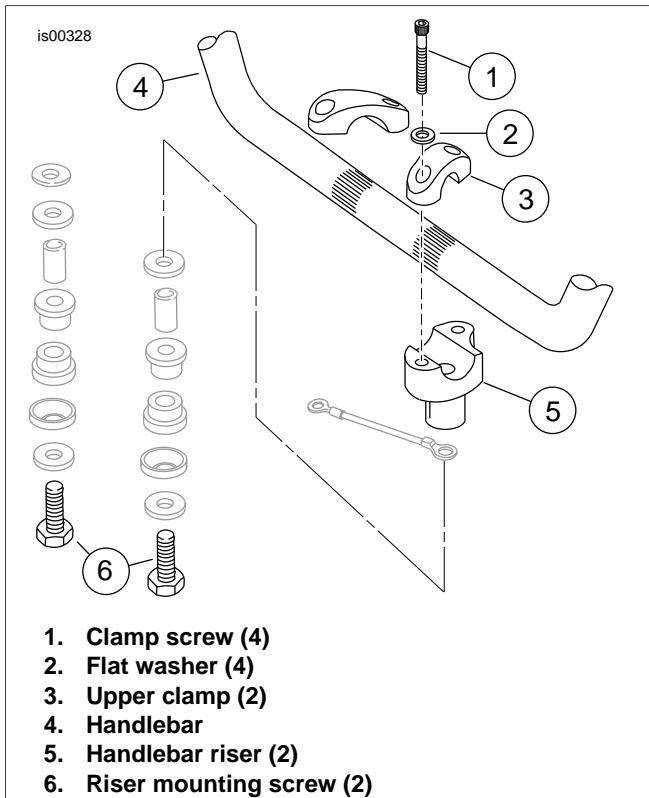

Figure 3. Handlebar Clamps and Risers (FLHR Shown)

Handlebar Removal - 2008 and Later Touring Models

NOTE

Cover the front fender and the fuel tank with clean shop towels to prevent scratching.

CAUTION

Remove brake line components carefully. Damage to seating surfaces can cause leakage. (00320a)

- Remove and save the button head screw on the underside of the fork stem and bracket assembly that holds the brake line manifold tee.
- Note the front brake line routing and the orientation of the banjo fittings. See the service manual and disconnect and remove the brake line. Save the banjo bolts, but discard the brake line gaskets.
- Remove the front brake master cylinder and clutch lever assemblies from the handlebar.
- See the service manual and disconnect the clutch cable from the clutch lever.

If the clutch cable is being replaced: Disconnect the clutch cable from the side cover and remove the cable from the vehicle.

- See the service manual and remove the headlamp assembly from the headlamp nacelle.
- See the service manual and disconnect the handlebar control wiring from the gray eight-way and black six-way main harness connectors inside the headlamp nacelle. Disconnect the electronic cruise control wiring from the two three-way connectors if equipped.
- See the service manual and perform the following:
 - Remove the right side switch housing assembly and harness.
 - Remove the left side switch housing assembly and wire harness.
- Remove and discard wire retaining clips attached to harnesses or the handlebar.
- If the left hand grip is not glued to the handlebar:** Remove the end cap from the grip if equipped. Remove the hand grip and set it aside for installation onto the new handlebar, if desired.
- Remove the end cap from the existing right hand grip if equipped, then remove the grip from the handlebar.

NOTES

The twist grip sensor in the right side of the handlebar has a seal cap that protects internal electrodes from dirt and moisture, and also acts as a retainer for the throttle grip.

To remove the hand grip, a slight tug may be necessary to release the index pins in the hand grip from the receptacle in the seal cap.

If the throttle grip IS NOT being replaced: After removing the grip, note if the seal cap is attached to the end of the twist grip sensor. If not, remove the seal cap from the index pins **inside** the throttle grip with a stiff piece of mechanics wire.

The stock twist grip sensor **MUST** be replaced with Twist Grip Sensor Kit (32310-08). See Figure 10.

- See the service manual and remove the stock twist grip sensor and twist grip sensor jumper harness. Save the jumper harness for later installation.
- See Figure 5. Reach inside the headlamp nacelle (5), remove the flange nut (7) to release the trim strip (6) at the top of the nacelle.

NOTE

For Australia, Brazil, England, Europe and Japan: See Figure 5. The flat head screws (8) have break-away heads and are not easily removable. To remove screws with break-away heads, make a pilot hole in the top of each screw with a center punch and back out the screw with a 1/8 in (3 mm) left-hand drill bit.

If that fails, use a 3/16-inch (5 mm) long shank drill bit to carefully drill off the heads of the break-away screws. Use a pliers to remove the screw shafts from the fork lock.

- See the service manual and follow the applicable steps to remove the handlebar cover, windshield and handlebar.

NOTE

Note the sequence of the riser mounting hardware for correct installation.

- Remove and discard the stock handlebar risers. Save the hardware for installation.

NOTE

DO NOT remove the wires from the Molex handlebar switch connector **pin housings** inside the nacelle.

- Note the wire colors and positions in each cavity of the **socket housings** leading from the switches. Refer to the appropriate service manual. Remove the wires (with socket terminals) from the socket housings.
- Use tape to wrap the wire terminal ends **from each source** to make separate leaders. Wrap each leader tightly enough to enter the grommet hole and pass easily through the **new** handlebar. Proceed to "INSTALLATION".

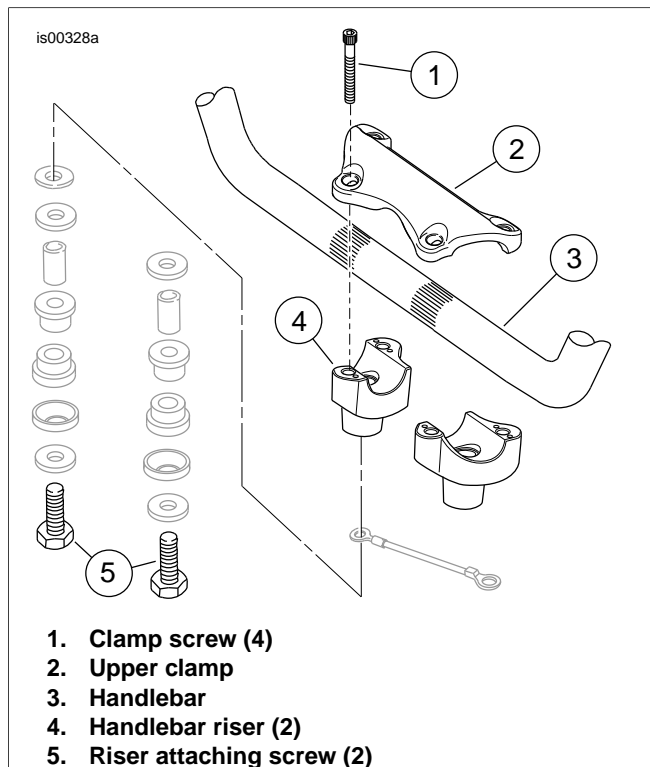

Figure 4. Handlebar Clamp and Risers (FLHR Shown)

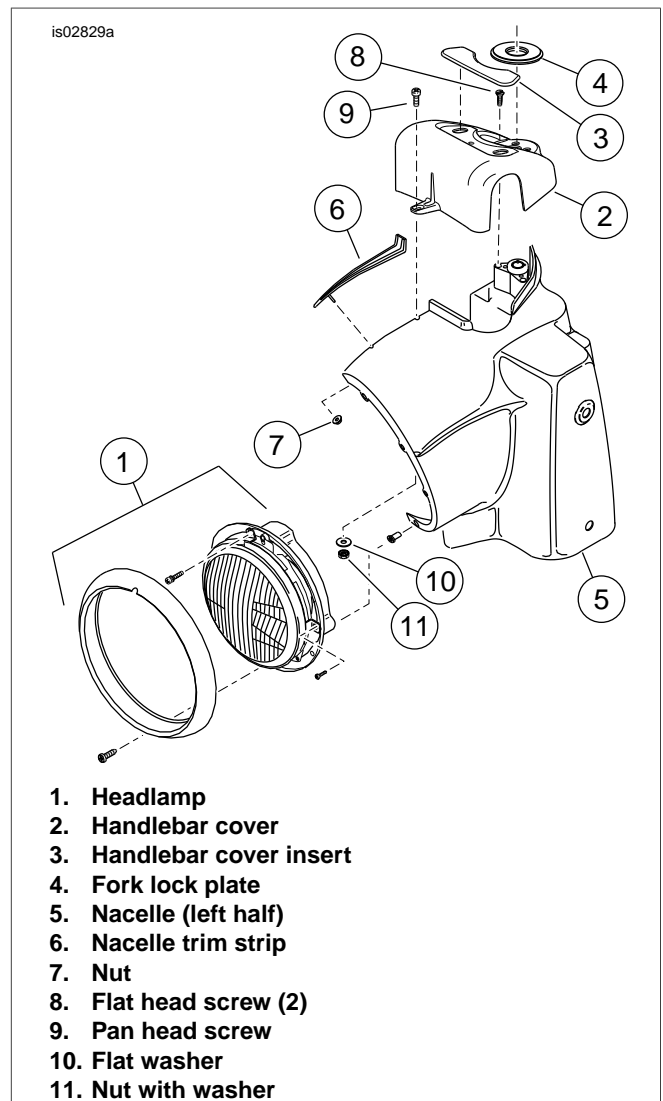

Figure 5. Nacelle, Headlamp and Handlebar Cover (FLHR/C Shown)

INSTALLATION

New Handlebar Wiring - Dyna, Softail, 2007 and Earlier Touring Models

- For models with handlebar-mounted turn signals:** See Figure 11. Slide one small grommet (3) onto each of the turn signal wire bundles, positioning the grommet close to the turn signal end.
- Apply a light coat of liquid soap, window cleaner or all-purpose lubricant to the right side switch wire bundle (and turn signal wire bundle, if equipped).

NOTE

The handlebar cover on FLHR models must be placed on the handlebar **before** the wires are installed through the riser wiring holes.

- For FLHR and FLHRC models,** slide a **new** handlebar cover (purchased separately) onto the handlebar.

4. **For FLHRS models**, see Figure 6.
 - a. Assemble the saved wind deflector (1) to the **new** adapter (2, purchased separately) using the three flanged screws (3) removed earlier.
 - b. Tighten the screws to 12-18 ft-lbs (16.3-24 Nm).
 - c. Assemble the **new** handlebar cover (4, purchased separately) to the adapter using the two flanged screws (5) and flanged nuts (6) from the adapter kit.
 - d. Tighten the screws to 12-18 ft-lbs (16.3-24 Nm).
 - e. Slide the handlebar cover/wind deflector assembly onto the handlebar.

5. Obtain three pieces of string, each of approximately 3.5 ft (1 M) long.
 - a. Tie a small weight (for example, a spare nut or washer small enough to fit through the center wire slot) to one end of **each** string.
 - b. Place the new handlebar on a horizontal surface so that the riser ends face upward.
 - c. Insert the weighted end of **two** of the strings into the **right side** riser **wiring** hole and tip the handlebar so that the weights slide out the right grip end of the handlebar.

If necessary, an air hose can be used to blow the weights and strings through the handlebar to the grip end of the bar.

- d. While verifying that the **non-weighted ends** of the strings remain extended out of the riser hole, pull the **weighted ends** out of the right grip end of the handlebar. Remove the weights from the strings.
- e. With a tweezers or similar tool, fish **one** string out through the **switch** wiring slot near the right side handlebar end.
- f. Repeat Steps 3b through 3e with the one remaining string and the **left side** handlebar end.

Allow the second string to remain extended out of the right side handlebar end.

Fish the string out through the **switch** wiring slot near the left-side handlebar end.

NOTE

The handlebar cover on FLHR models must be placed on the handlebar **before** the wires are installed through the riser wiring holes.

6. Slide a **new** handlebar cover (purchased separately) onto the handlebar. Verify that the strings installed earlier remain extended out of the riser holes on the underside of the cover.
7. Apply a **light** coat of liquid soap, window cleaner, or all-purpose lubricant to the right side switch and turn signal wire bundles, if equipped.

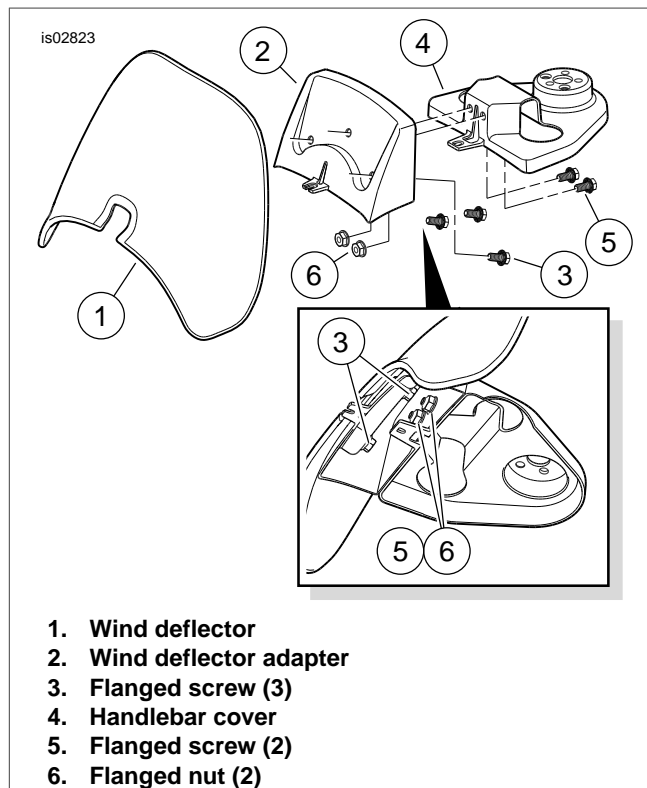

Figure 6. Handlebar Cover/Wind Deflector Assembly (FLHRS)

WARNING

Carefully pull the wires through hole in handlebar to prevent stripping the wires. Stripped wires can cause short circuits and damage vehicle electrical components, which could cause loss of vehicle control resulting in death or serious injury. (00418b)

8. Pull the taped ends of the wire bundles through the wire exit hole near the bottom of the right side riser.

WARNING

Grommets in each of the wiring holes in the handlebar must remain in position after routing the wiring through the handlebar. Operation without the grommets in place can damage wires, causing a short circuit which could result in death or serious injury. (00416d)

9. See Figure 11. Slide a grommet (2) onto both of the wire bundles sticking out of the riser wire hole and insert the grommet into the riser hole in the handlebar.
10. Tie the end of the string from the left side **switch wire** hole to the left side switch wire bundle.
11. If necessary, apply a **light** coat of liquid soap, window cleaner or all-purpose lubricant to the left side switch wire bundle.
12. Route the left side switch wire bundle through the switch housing similar to that shown in Figure 6 for the right side wiring. Gently feed the wire bundle into the left side switch wire hole.

Pull the bundle down through the new handlebar and out through the wire exit hole near the bottom of the left side riser.

13. Loosely fasten the brake lever and clutch-lever clamps to the new handlebar.
14. Loosely fasten the handlebar switch housings to the new handlebar.
15. Remove the tape from the ends of the wire bundles.
16. Check for electrical continuity between the handlebar and each wire in the wire bundles. Continuity would indicate a short circuit, which would require examination of the wires and routing in the switch housing.

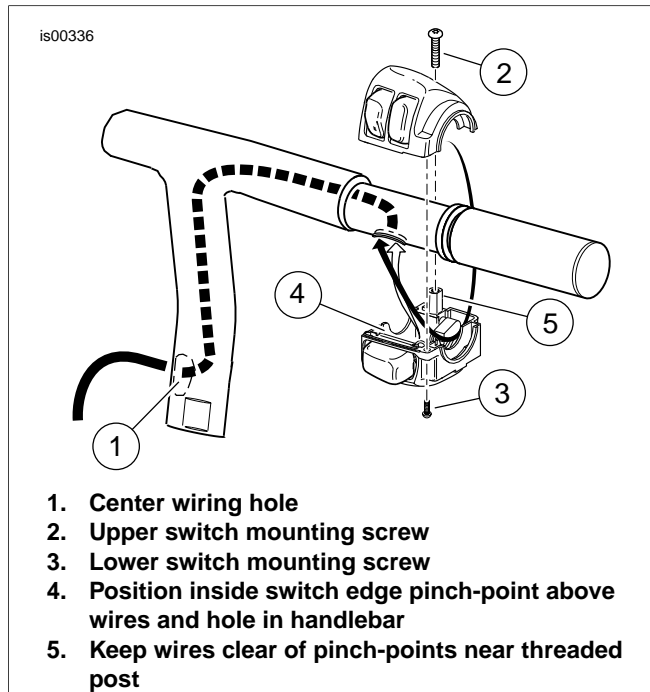

Figure 7. Switch Housing Wire Routing (Dyna, Softail and 2007-Earlier Touring)

New Handlebar Installation - Dyna, Softail, 2007 and Earlier Touring Models

1. **Dyna and Softail models:**
 - a. Route the switch harnesses down through the large oval opening in the upper fork bracket, then route them to the switch connectors under the fuel tank as previously noted.
 - b. Route both turn signal harnesses down through the large oval opening in the upper fork bracket, then route them to the 6-way turn signal pin housing under the right side of the fuel tank as previously noted.

NOTE

2007 and later models use Molex connectors. 2006 and earlier vehicles use Deutsch connectors. See the service manual for disconnection and connection procedures.

2. Refer to the notes made during the removal steps and the appropriate section and wiring diagrams in the service manual and proceed as follows:
 - a. Insert each socket terminal from the left side switch harness into the correct cavity of the **gray** socket housing removed earlier.
 - b. Insert each socket terminal from the right side switch harness into the correct cavity of the **black** socket housing removed earlier.
 - c. Insert each socket terminal leading from the turn signals into the correct cavity of the Multilock socket housing removed earlier.
 - d. Install the clips and/or wire guides saved earlier.
3. **Touring Models:** Route switch and turn signal socket housings into the headlamp nacelle.
4. Connect the gray 6-way switch wire socket housing coming from the bottom center of the handlebar to the gray 6-way pin housing.
Connect the black 6-way switch wire socket housing to the black 6-way pin housing.
5. Connect the black 6-way Multilock connector coming from the bottom center of the handlebar to the black 6-way Multilock pin housing.

WARNING

When servicing the fuel system, do not smoke or allow open flame or sparks in the vicinity. Gasoline is extremely flammable and highly explosive, which could result in death or serious injury. (00330a)

6. **Dyna and Softail models:** See the service manual and secure the fuel tank to the frame.

CAUTION

Improperly aligned handlebars can contact the fuel tank when turned to the left or right. Contact with the fuel tank can cause cosmetic damage. (00372a)

7. Slowly turn the front wheel to the full right fork stop and then the full left fork stop to be sure the handlebar does not contact the fuel tank. If contact occurs and the handlebars are properly centered, raise the handlebar angle as necessary until proper clearance is attained.
8. Remove the riser bolts one at a time. Apply a small amount of Loctite® 271 (Red) to the bolt threads and install again. See the service manual and tighten the riser bolts to specification.
9. See the service manual and follow the instructions given to install the throttle control cables and a new (purchased separately) or original right hand grip/throttle sleeve assembly.
10. Adjust the position of the switch housing and the brake lever assembly on the handlebar for rider comfort and posture. The brake master cylinder must be horizontally level.

NOTE

Tighten the top **brake lever clamp** screw before tightening the bottom screw.

11. Tighten the top then the bottom brake lever clamp screws to 71-80 **in-lbs** (8.0-9.0 Nm).

NOTE

Tighten the lower switch housing screw before tightening the upper screw. This will leave any gap in the switch housing at the front for best appearance.

12. Tighten the lower then the upper **switch housing** screws to 35-45 **in-lbs** (4.0-5.1 Nm).
13. Verify that the right hand grip/throttle sleeve rotates and returns freely and does not bind on the handlebar or switch housing.

NOTE

If the hand grips are patterned, align the pattern on the left hand grip with the pattern on the right hand grip while the throttle is in the fully-closed position.

14. Install a new (purchased separately) or original hand grip on the left end of the new handlebar according to the hand grip instruction sheet or the appropriate service manual.
15. See the service manual and adjust the positions of the switch housing and the clutch lever assembly on the handlebar for rider comfort and posture.
16. Tighten the top then the bottom clutch lever clamp screws to 71-80 **in-lbs** (8.0-9.0 Nm).
17. Tighten the lower then the upper **switch housing** screws to 35-45 **in-lbs** (4.0-5.1 Nm).

New Handlebar Wiring - 2008 and Later Touring Models

NOTE

*The handlebar cover on FLHR models must be placed on the handlebar risers **before** the wires are installed through the riser wiring holes.*

1. Slide a **new** handlebar cover (purchased separately) onto the handlebar risers. Check that the strings installed earlier remain extended out of the riser wiring holes on the underside of the cover.
2. Obtain three pieces of string, mechanic's wire or equivalent, each of sufficient length to extend inside the handlebar, from the end of the bar to the lower center wire slot, plus 6-12 in (15-30 cm) of additional length to extend beyond the openings.
 - a. Tie a small weight (for example, a spare nut or washer small enough to fit through the center wire slot) to one end of each string.
 - b. Insert the weighted end of **two** of the strings into the **right side** handlebar end, and tip the handlebar so that the weights and strings slide down the handlebar to the lower center wire slot.

If necessary, an air hose can be used to blow the weights and strings through the handlebar to the center slot.

- c. While verifying that the **non-weighted ends** of the strings remain extended out of the right side handlebar end, pull the **weighted ends** out of the lower center wire slot. Remove the weights from the strings.
 - d. With a tweezers or similar tool, fish **one** string out through the **switch** wiring slot near the right side handlebar end.

Allow the second string to remain extended out of the right side handlebar end.
 - e. Repeat Steps 1b through 1d with the remaining string and the **left side** handlebar end.

Fish the string out through the **switch** wiring slot near the left side handlebar end.
3. See Figure 11. Slide the grommets (2), flange end first onto the switch harnesses, positioning the grommet close to the switch end.

For models with handlebar-mounted turn signals, slide one small grommet (3) onto each of the turn signal wire bundles, positioning the grommet close to the turn signal end.

NOTE

*DO NOT use the stock twist grip sensor with the new handlebar. The small green connector on the stock sensor is not compatible with internally wired handlebars. The stock sensor **MUST** be replaced with Twist Grip Sensor Kit (32310-08). See Figure 10.*

4. Use tape to wrap the wire terminals on the ends of the twist grip sensor wires to make a single leader. Wrap the leader tightly enough to pass easily through the **new** handlebar.
5. Tie the end of the string from the right side handlebar end hole to the twist grip sensor harness.
6. Tie the end of the string from the right side **switch wire** hole to the right side switch harness.

WARNING

Wiring in the switch housings must be routed exactly as shown. Pinch points in the switch housings can short-circuit or sever wires, which could cause loss of control resulting in death or serious injury. (00415b)

NOTE

Apply a light coat of liquid soap, window cleaner or all purpose lubricant to harnesses before feeding the harnesses into the handlebar.

7. Gently feed the twist grip sensor harness into the right side handlebar end.

See Figure 8. Route the right side switch wire bundle through the switch housing as shown. Gently feed the harness into the right side switch wire hole.

Pull the bundles down through the new handlebar and toward the center of the bar, while fitting the index tabs on the twist grip sensor into the slots on the end of the

handlebar. One index tab and slot are smaller than the other for ease of assembly.

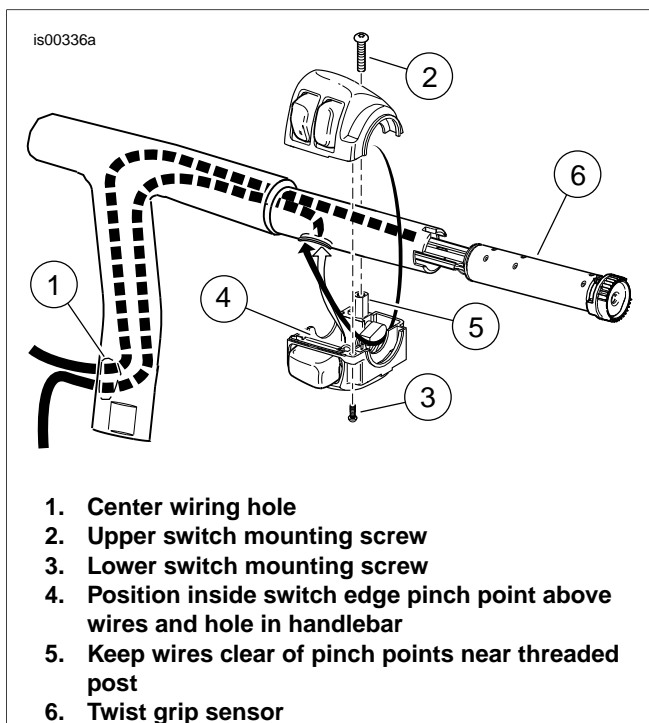

Figure 8. Switch Housing and Twist Grip Sensor Wire Routing (2008 and Later Touring)

WARNING

Carefully pull the wires through hole in handlebar to prevent stripping the wires. Stripped wires can cause short circuits and damage vehicle electrical components, which could cause loss of vehicle control resulting in death or serious injury. (00418b)

8. Pull the taped ends of the wire harnesses through the center hole of the handlebar.

WARNING

Grommets in each of the wiring holes in the handlebar must remain in position after routing the wiring through the handlebar. Operation without the grommets in place can damage wires, causing a short circuit which could result in death or serious injury. (00416d)

9. Tie the end of the string from the left side switch wire hole to the left side switch harness.
10. Route the left side switch harness through the switch housing similar to that shown in for the right side wiring. Feed the harness into the left side switch wire hole. Pull the bundle down through the new handlebar and toward the center of the bar.

NOTE

Insert the right side grommet into the handlebar slot with the flange toward the center of the bar.

11. See Figure 11. Insert the switch wire grommets (2) into place in the switch wire holes in the handlebar.
12. Loosely fasten the brake lever and clutch lever clamps to the new handlebar.

13. Loosely fasten the handlebar switch housings to the new handlebar.
14. Remove the tape from the ends of the harnesses.
15. Check for electrical continuity between the handlebar and each wire in the harnesses. Continuity indicates a short circuit, which requires examination of the wires and routing in the switch housing.

New Handlebar Installation - 2008 and Later Touring Models

NOTE

See the service manual for disconnection and connection procedures.

1. Insert each socket terminal from the right side switch harness into the correct cavity of the black socket housing removed earlier.
2. Connect the gray socket housing to the gray eight-way pin housing inside the nacelle. Connect the black socket housing to the black six-way pin housing inside the nacelle. If equipped, connect the three-way cruise control pin and socket housings in the same manner.
3. Obtain the PVC tubing from the Twist Grip Sensor Kit (purchased separately). Install the tubing over ALL of the wires coming from the twist grip sensor.
4. Obtain the six-way black Molex pin housing from the Twist Grip Sensor Kit (purchased separately). Insert each pin terminal from the twist grip sensor into the correct cavity of the pin housing as follows:

From the **yellow** conduit,

- a. BLACK wire to cavity 1
- b. WHITE wire to cavity 2
- c. RED wire to cavity 3

From the **black** conduit,

- a. BLACK wire to cavity 4
- b. WHITE wire to cavity 5
- c. RED wire to cavity 6

5. Connect the six-way black Molex pin housing from the twist grip sensor to the black six-way socket housing inside the nacelle.

Position the previously installed PVC tubing to prevent chafing of the twist grip sensor wires inside the nacelle.

CAUTION

Improperly aligned handlebars can contact the fuel tank when turned to the left or right. Contact with the fuel tank can cause cosmetic damage. (00372a)

6. Slowly turn the front wheel to the full-right fork stop and then the full-left fork stop to be sure the handlebar does not contact the fuel tank. If contact occurs and the handlebars are properly centered, raise the handlebar angle as necessary until proper clearance is attained.
7. One at a time, remove the riser bolts. Apply a small amount of Loctite® 271 (Red) to the bolt threads and install. Tighten the riser bolts to 30-40 ft-lbs (41-54 Nm).

8. Install a new (purchased separately) or original hand grip on the left end of the new handlebar according to the hand grip instruction sheet or an appropriate service manual.
9. Adjust the positions of the switch housing and the clutch lever assembly on the handlebar for rider comfort.
10. Tighten the top then the bottom clutch lever clamp screws to 72-108 **in-lbs** (8.1-12.2 Nm).
11. Tighten the lower then the upper switch housing screws to 35-45 **in-lbs** (4.0-5.1 Nm).

NOTE

If the hand grips are patterned, align the pattern on the right hand grip with the pattern on the left hand grip while the throttle is in the fully-closed position.

12. Refer the appropriate service manual, and follow the instructions given to install the new (purchased separately) or original right hand grip/throttle sleeve.
13. Adjust the position of the switch housing and the brake lever assembly on the handlebar for rider comfort. The brake master cylinder must be level.

NOTE

*Tighten the top **brake lever clamp** screw before tightening the bottom screw.*

14. Tighten the top then the bottom brake lever clamp screws to 72-108 **in-lbs** (8.1-12.2 Nm).

NOTE

Tighten the lower switch housing screw before tightening the upper screw. This will leave any gap in the switch housing at the front for best appearance.

15. Tighten the lower then the upper switch housing screws to 35-45 **in-lbs** (4.0-5.1 Nm).
16. Verify that the right hand grip/throttle sleeve rotates and returns freely and does not bind on the handlebar or switch housing.

FINAL ASSEMBLY

Softail and Dyna Models

WARNING

Replace brake line gaskets. Re-using original gaskets can cause brake failure and loss of vehicle control, which could result in death or serious injury. (00318a)

CAUTION

Avoid leakage. Be sure gaskets, banjo bolt(s), brake line and caliper bore are clean and undamaged before assembly. (00321a)

1. Carefully inspect the **new** brake line for damage or defects, and replace if damaged. Install the brake line per the service manual instructions or the instructions included with the Brake Line Kit.
2. See the service manual and bleed the brakes.
3. See the service manual and install the clutch cable to the clutch lever or install a **new** clutch cable (sold separately).

Touring Models

WARNING

The rider's safety depends upon the correct installation of this kit. Dealer installation is required for vehicles equipped with ABS brakes. Proper installation of this kit requires the use of special tools available only through a Harley-Davidson Dealer. An improperly serviced brake system can adversely affect brake performance, which could result in death or serious injury. (00578b)

1. To avoid possible damage to the brake hose, verify that the trim strips remain installed on the inside edges of the headlamp nacelle. Replace the strips if missing, cracked or damaged.

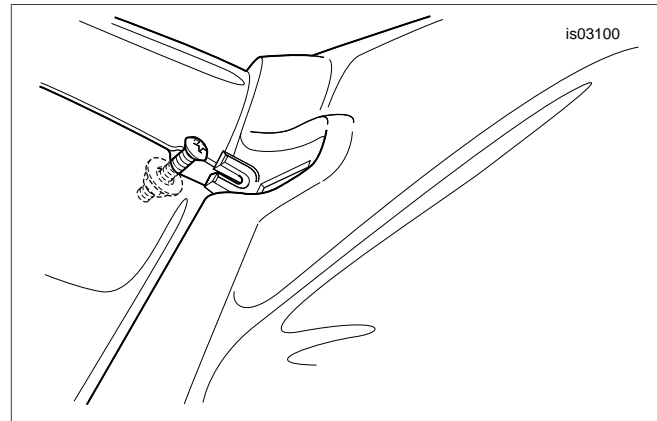

Figure 9. Wind Deflector Assembly to Nacelle (FLHRS Models)

2. Models with wind deflectors:

- a. Obtain the **new** handlebar clamp cover (sold separately), and the wind deflector and three hex head serrated flange screws removed earlier. Fasten the cover to the wind deflector with the screws and alternately tighten to 12-18 ft-lbs (16.3-24.4 Nm).
- b. Position the deflector and cover assembly onto the flange at the top of the headlamp nacelle.
- c. Loosely assemble the pan head screw, flange nut and flat washer removed earlier.
- d. See Figure 9. Holding the screw assembly, reach inside the headlamp nacelle and insert **just the screw head** up through the opening to engage the slot in the tab at the front of the wind deflector. The nut and flat washer should remain inside the nacelle. Tighten the screw to 10-20 **in-lbs** (1.1-2.3 Nm).

Models without wind deflectors:

- a. Position a **new** cover onto the flange at the top of the headlamp nacelle.
- b. Insert the screw through the hole at the front of the handlebar cover and the top of the headlamp nacelle. Reach inside the nacelle and install the nut and flat washer onto the screw threads. Tighten the screw to 10-20 **in-lbs** (1.1-2.3 Nm).

NOTE

For North America: Install new handlebar cover using two flat head screws (removed earlier).

For Australia, Brazil, England, Europe and Japan: Install new handlebar cover using two **new** screws (2935A, purchased separately).

3. Install the two screws to secure the handlebar clamp cover to the fork lock mechanism.

For North America: Tighten the flat head screws to 10-20 **in-lbs** (1.1-2.3 Nm).

For Australia, Brazil, England, Europe and Japan: Tighten the special screws until the break-away heads snap off.

4. Press the original fork lock plate into position on the handlebar cover.
5. Insert the hook of the trim strip into the slot on the handlebar cover. Insert the weld stud on the trim strip into the hole at the top of the headlamp nacelle, and reach inside the nacelle to install the flange nut. Tighten the nut to 15-20 **in-lbs** (1.7-2.3 Nm).
6. See the service manual and install the headlight into the nacelle.

WARNING

Replace brake line gaskets. Re-using original gaskets can cause brake failure and loss of vehicle control, which could result in death or serious injury. (00318a)

CAUTION

Avoid leakage. Be sure gaskets, banjo bolt(s), brake line and caliper bore are clean and undamaged before assembly. (00321a)

7. Carefully inspect the **new** brake line or lines (sold separately) for damage or defects, and replace if damaged. Install per the instructions included with the brake lines.
8. See the service manual and bleed the brakes.
9. See the service manual and install the clutch cable to the clutch lever or install a **new** clutch cable (sold separately).



SAFETY CHECK

⚠ WARNING

Be sure that steering is smooth and free without interference. Interference with steering could result in loss of vehicle control and death or serious injury. (00371a)

- Be sure wires, clutch cables, throttle/idle cables and brake lines do not pull tight when handlebars are turned fully to left or right fork stops.

⚠ WARNING

Connect positive (+) battery cable first. If positive (+) cable should contact ground with negative (-) cable connected, the resulting sparks can cause a battery explosion, which could result in death or serious injury. (00068a)

1. Verify that the ignition/light key switch is turned to the OFF position.
See the service manual and connect the battery cables or install the main fuse.

⚠ WARNING

Be sure that all lights and switches operate properly before operating motorcycle. Low visibility of rider can result in death or serious injury. (00316a)

2. Turn the ignition/light key switch to IGNITION and test each handlebar switch for proper operation.
3. For 2005 and earlier FXDL and FXDWG models:

⚠ WARNING

Be sure plug in lower forward section of rear fender is installed. Operation without plug installed could allow tire contact with wiring harness. Tire contact with wiring harness can cause wire damage, which could result in death or serious injury. (00456b)

- Inspect the lower forward section of the fender inside the rear wheel well. A 3 in (76 mm) square hole in the fender should be covered with a rubber plug.
- If the plug is damaged, loose or missing, it **MUST** be replaced (59150-90, available from a Harley-Davidson

dealer). Without this plug in place, the wire harness could come out of the opening and contact the rear tire, causing rear lighting failure or other serious electrical problems.

4. Turn the handlebar to the left and right steering stops, testing the handlebar control functions at each stop.
5. Apply the front brake hand lever to test operation of the brake lamp.
6. Verify that the throttle operates properly.
7. Refer to the service manual and follow instructions to install the seat.

⚠ WARNING

After installing seat, pull upward on seat to be sure it is locked in position. While riding, a loose seat can shift causing loss of control, which could result in death or serious injury. (00070b)

⚠ WARNING

Before starting engine, be sure throttle control will snap back to idle position when released. A throttle control that prevents engine from automatically returning to idle can lead to loss of control, which could result in death or serious injury. (00390a)

⚠ WARNING

After repairing the brake system, test brakes at low speed. If brakes are not operating properly, testing at high speeds can cause loss of control, which could result in death or serious injury. (00289a)

⚠ WARNING

Be sure headlamp, tail and stop lamp and turn signals are operating properly before riding. Poor visibility of rider to other motorists can result in death or serious injury. (00478b)

8. Test tail lamps for proper operation.



SERVICE PARTS

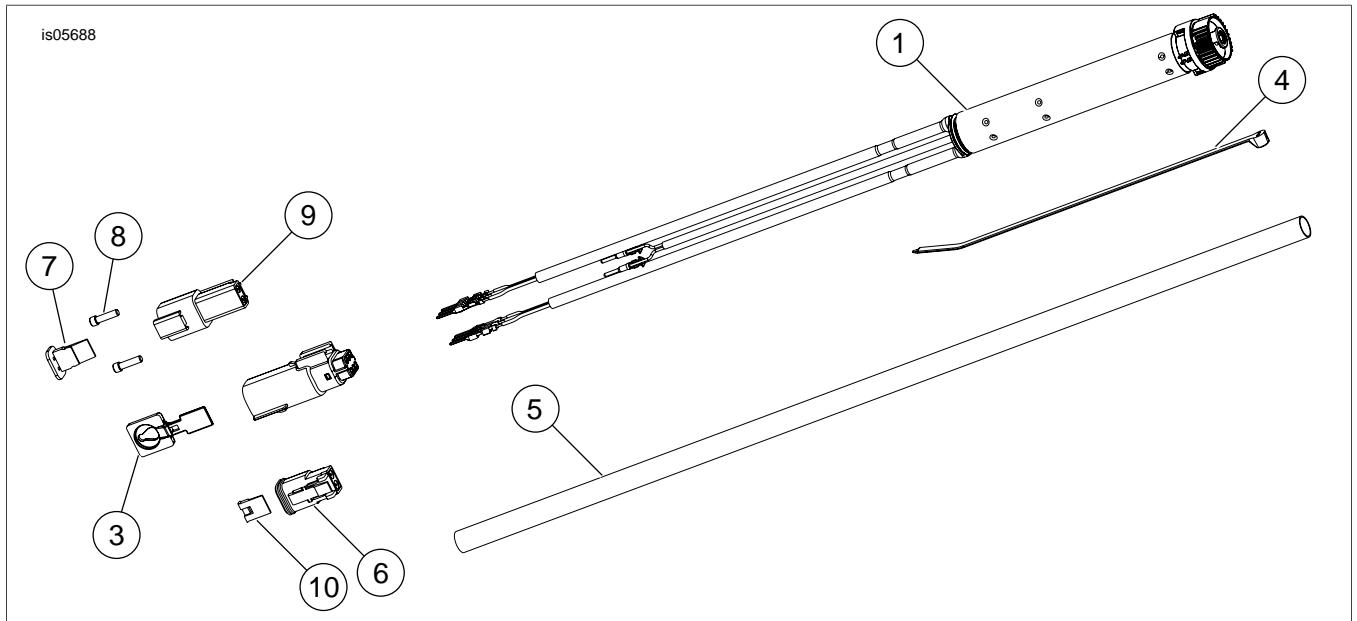
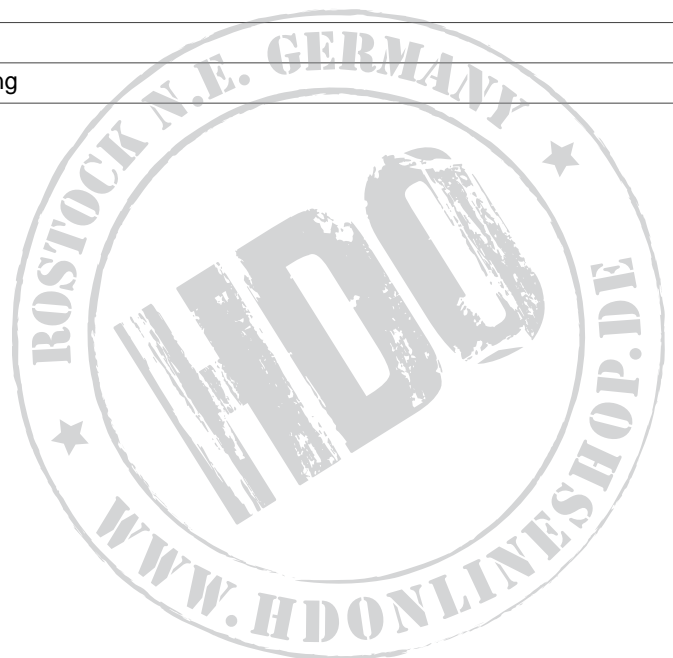

Figure 10. Service Parts: Twist Grip Sensor Kit (32310-08)

Table 1. Service Parts: Twist Grip Sensor Kit (32310-08)

Item	Description (Quantity)
Items for Twist Grip Sensor:	
1	Sensor, twist grip (for internally-wired handlebars)
2	Pin housing, six-way
3	Retainer, T-stud
4	Cable strap
5	PVC tubing
Items used with Heated Hand Grips only:	
6	Socket housing, two-way
7	Secondary lock, two-way socket housing
8	Seal pin (plug) (2)
9	Pin housing, two-way
10	Secondary lock, two-way pin housing



is00334b

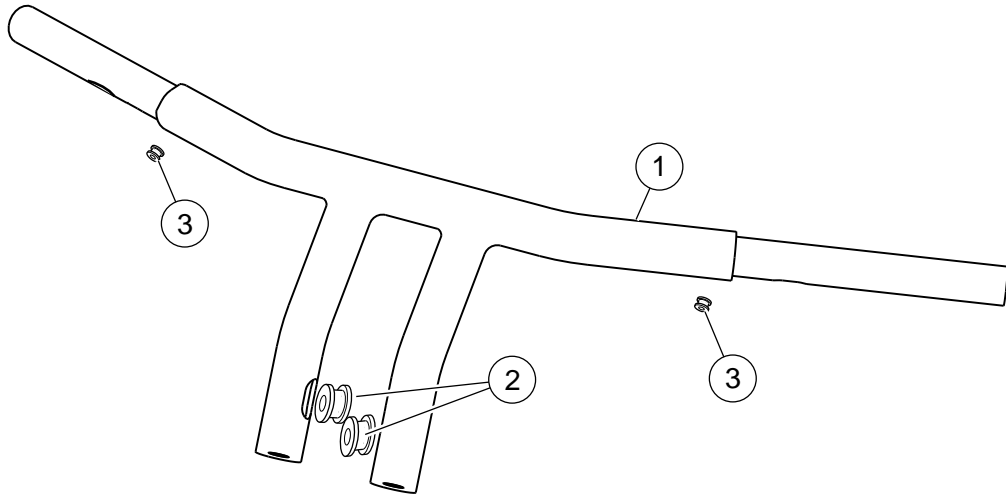

Figure 11. Service Parts

Table 2. Service Parts

Item	Description (Quantity)	Part Number
1	Handlebar, Street Slammer	Not Sold Separately
2	Handlebar grommet, large (2)	11386
3	Handlebar grommet, small (2) (for handlebar-mounted turn signals only)	11398

