



# INSTRUCTIONS

-J05549

2011-10-07

## DELUXE CLAMP AND RISER KIT

### GENERAL

#### Kit Number

55900023

#### Models

For model fitment information, see the P&A Retail Catalog or the Parts and Accessories section of [www.harley-davidson.com](http://www.harley-davidson.com) (English only).

#### Installation Requirements

##### ▲ WARNING

The rider's safety depends upon the correct installation of this kit. Use the appropriate service manual procedures. If the procedure is not within your capabilities or you do not have the correct tools, have a Harley-Davidson dealer perform the installation. Improper installation of this kit could result in death or serious injury. (00333a)

##### NOTE

This instruction sheet refers to service manual information. A service manual for this year/model motorcycle is required for this installation and is available from a Harley-Davidson dealer.

#### Kit Contents

See Figure 1 and Table 1.

### PREPARATION

##### NOTE

For vehicles equipped with security siren:

- **2007 and later:** Verify that the Hands-Free Fob is present.
- **2006 and earlier:** Disarm the siren with the key fob.
- **ALL vehicles:** Turn the ignition key switch to IGNITION.

#### For Vehicles With Main Fuse:

##### ▲ WARNING

To prevent accidental vehicle start-up, which could cause death or serious injury, remove main fuse before proceeding. (00251b)

1. See the service manual and remove the main fuse.

##### NOTE

Cover the fuel tank with H-D Service Covers or clean shop towels to prevent scratching the finish.

2. See the service manual and remove the handlebars, handlebar clamp and risers. Note the order of removed riser hardware. Note all electrical, cable and brake line connections and routings.

### INSTALLATION

1. Install the riser mounting hardware in the same order as removed, with the following exceptions: **For 2005 and earlier FXDL models:** See Figure 1. Install two flat washers (1) immediately below each riser. **For 2005 and earlier FXST and FXSC models:** Install one flat washer (1) immediately below each riser. **For all other models:** Discard flat washers (1).
2. Loosely install lower handlebar clamps to upper fork bracket using lower handlebar clamp fasteners.
3. Place handlebars on lower handlebar clamps. Install upper handlebar clamps. Install but do not tighten clamp fasteners.
4. Using knurled areas of handlebar as a guide, center handlebars between lower handlebar clamps.
5. Raise handlebars to normal riding position and hold in position.
6. Secure handlebars in clamp:
  - a. Hand-tighten two front screws (4).
  - b. Snug the two rear screws (4).
  - c. Tighten front handlebar clamp screws to 16.3–20.3 N·m (12–15 ft-lbs).
  - d. Tighten rear handlebar clamp screws to 16.3–20.3 N·m (12–15 ft-lbs). A slight gap between upper and lower clamps should exist at front.
7. Tighten lower riser mount screws to 40.7–54.3 N·m (30–40 ft-lbs).

### RETURN TO SERVICE

1. See the service manual. Install right and left switch assemblies, throttle control, clutch lever assembly and front master cylinder assembly.
2. Test front brake lever for pressure and operation.
3. See the service manual and install the main fuse.

##### ▲ WARNING

Be sure that all lights and switches operate properly before operating motorcycle. Low visibility of rider can result in death or serious injury. (00316a)

4. Turn the ignition/light key switch to IGNITION and test lights and switches for proper operation.

-J05549

Many Harley-Davidson® Parts & Accessories are made of plastics and metals which can be recycled. Please dispose of materials responsibly.

1 / 2

5. Apply brake lever to test stop light lamp.

## SERVICE PARTS

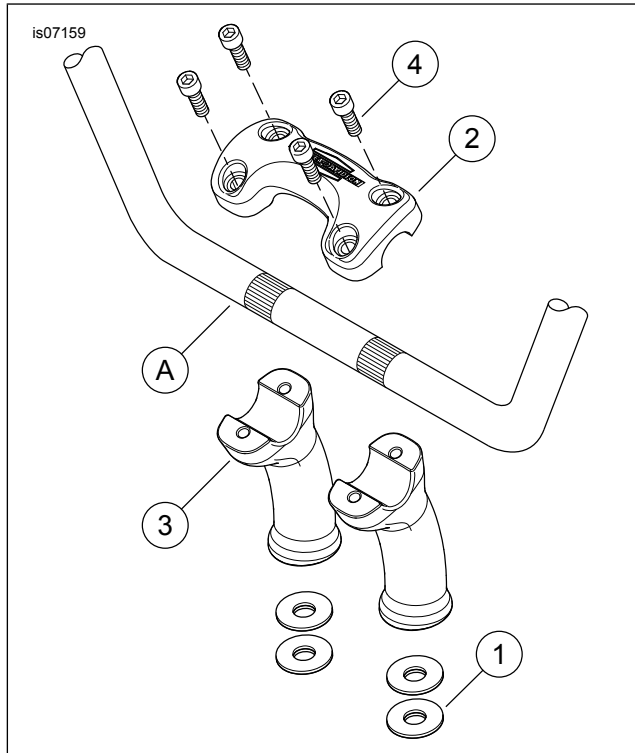

Figure 1. Service Parts: Pullback Riser Kit

Table 1. Service Parts

Item	Description (Quantity)	Part Number
1	Washer (4)	6366
2	Clamp, handlebar	Not Sold Separately
3	Riser, handlebar (2)	Not Sold Separately
4	Screw, socket head (4)	3494A
<b>Items mentioned in text, but not included in kit.</b>		
A	Handlebar	