



INSTRUCTIONS

-J04301

REV. 2006-11-03

FL SOFTAIL PROFILE LOW FRONT SUSPENSION KIT

GENERAL

Kit Number

54758-07

Models

For model fitment information, please see the P&A Retail Catalog or the Parts and Accessories section of www.harley-davidson.com (English only).

Additional Parts Required

WARNING

This Front End Lowering Kit cannot be used independently. It must be used with an appropriate Low Rear Suspension Kit or handling and cornering can be affected, which could distract the rider, causing loss of control and death or serious injury. (00429b)

When installing this kit on Softail models (except FLSTN models), proper installation of this kit also requires installation of one of the following kits: Softail Lowered Rear Shocks (54651-05), Shock Absorber Kit (54652-05), or Rear Lowering Kit (54001-04).

Proper installation of this kit also requires the following: two fork oil Seals (45875-84A), two o-rings (45845-77), two screws with crush washer (45405-75A), and two drain screws with washers (45858-77).

Proper installation of this kit also requires the following special tools: FORK TUBE HOLDER (HD-41177), FORK SEAL/BUSHING TOOL (HD-34634) and FRONT FORK OIL LEVEL GAUGE (HD-59000-B).

WARNING

The rider's safety depends upon the correct installation of this kit. Use the appropriate service manual procedures. If the procedure is not within your capabilities or you do not have the correct tools, have a Harley-Davidson dealer perform the installation. Improper installation of this kit could result in death or serious injury. (00333a)

NOTE

This instruction sheet references Service Manual information. A Service Manual for your model motorcycle is required for this installation and is available from a Harley-Davidson Dealer.

Kit Contents

See Figure 6 and Table 1.

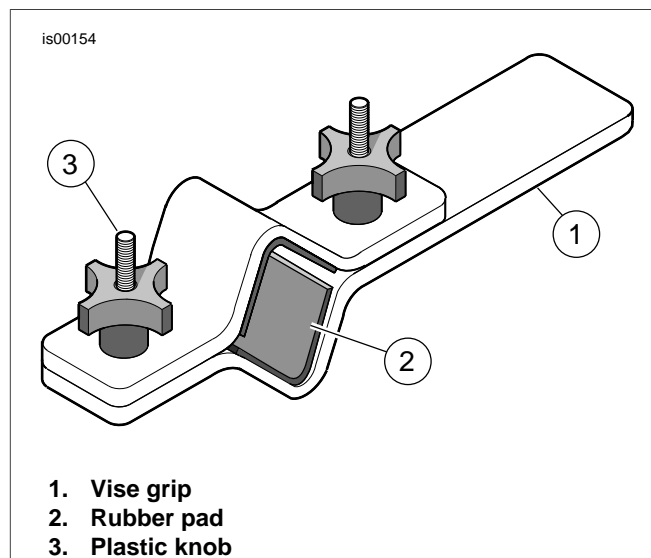

Figure 1. Fork Tube Holder (HD-41177)

REMOVAL

1. Place suitable blocking under frame to raise front wheel several inches off the floor. For best results, use a hydraulic center stand on a level surface.
2. Refer to the appropriate Service Manual and remove the front forks.
3. Move forks to bench area. Place suitable drain pan on floor beneath a vise.

INSTALLATION

Fork Disassembly

1. See Figure 6. Remove nuts (R), lockwashers (Q), flat washers (P) and axle cap (S) from studs at end of fork slider.
2. See Figure 1. Obtain FORK TUBE HOLDER (HD-41177) and proceed as follows:
 - a. Clamp end of tool in vise (1) in a horizontal position with plastic knobs facing toward you.
 - b. With the fork cap bolt topside, clamp fork tube between rubber pads (2) on inboard side of tool. Tighten knobs (3) until fork tube is securely held.

NOTE

Refer to Figure 6 for Steps 3-17.

3. Remove fork cap bolt (A) and spacer (M) from fork tube plug (B). Remove quad ring seal (4). Save bolt and spacer but discard quad ring seal.

4. Using wrench flat, slowly unthread fork tube plug (B) from fork tube (E). Be aware that fork tube plug is under spring pressure, so have a firm grasp on plug as the last thread is turned.
5. Remove fork spring (1) from fork tube.
6. Remove fork assembly from fork tube holder.
7. Turning fork upside down, drain fork oil into drain pan. For best results, slowly pump fork tube and slider at least 10 times.
8. Install fork spring back into fork tube.
9. Place a shop rag on the floor, and turning fork assembly upside down, press end of spring against rag. While compressing spring to prevent rotation of damper tube, remove screw and washer (O) from end of fork slider. Use air impact wrench for best results.
10. Remove and discard fork spring (1).
11. Using pick tool, remove retaining clip (F) between fork slider and fork tube.
12. Remove fork tube (E) from fork slider. Slide fork tube gently in a slide hammer motion against the slider to remove the seal and bushing from slider.
13. Slide fork oil seal (G), slider spacer (H) and slider bushing (I) off end of fork tube (E).

NOTE

The lower stop (J) may come out with the damper tube or remain in the slider tube. Ensure that the lower stop is removed from the slider tube.

14. Remove the lower stop (J).
15. Remove damper tube (2) from fork tube.
16. Remove rebound spring (D) from damper tube.
17. Repeat Steps 1-16 for the opposite side fork assembly.

NOTE

Thoroughly clean and inspect wear items.

Fork Assembly

NOTE

Refer to Figure 6 for the following procedure.

1. Obtain new Damper Tube (2) from kit and install rebound spring (D) over the lower end.
2. With the wear ring topside, slide new damper tube into fork tube, so that tube end drops through hole at bottom of fork tube (E). Install lower stop (J) on the lower end of damper tube.
3. Install fork slider (L) in fork tube holder. Inspect bushing (K) (45866-84) and replace, if necessary. If removed earlier, install bushing on fork tube (E). Slide fork tube into the fork slider.

NOTE

Ensure the fork spring is installed with dense section of coils to the bottom.

4. Obtain new fork spring (1) from kit. Install new fork spring into fork tube.
5. Remove fork assembly from fork tube holder.

6. Place a shop rag on the floor, and turning fork assembly upside down, press end of spring against rag.



Figure 2. Fork Seal/Bushing Tool (HD-34634)

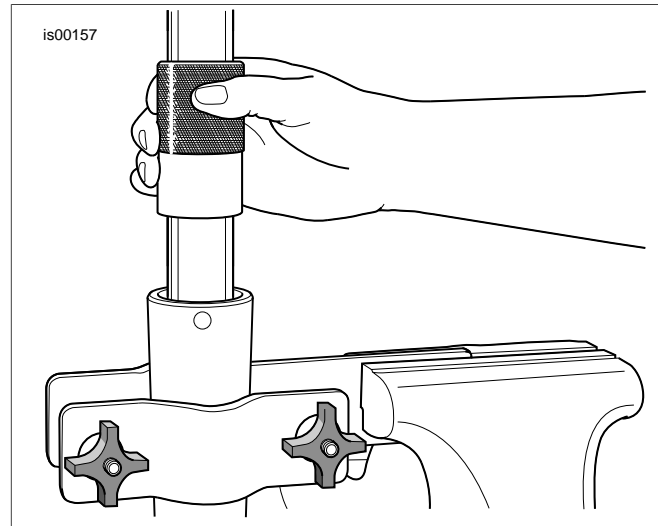

Figure 3. Install Fork Oil Seal

7. Install new screw with copper crush washer (O) (45405-75A, not included). Slide screw through hole at bottom of fork slider and start into end of damper tube.
8. While compressing spring to prevent rotation of damper tube, tighten the screw to 11-18 ft-lbs (15-25 Nm).
9. Install fork assembly back in fork tube holder and clamp it on the slider.
10. If necessary, obtain new slider bushing (I) (45940-84, not included). Coat slider bushing ID with clean fork oil. Slide slider bushing (I) down fork tube.
11. Slide seal spacer (H) down fork tube until it contacts slider bushing. Ensure flange surface of seal spacer is facing up.
12. Obtain new fork oil seal (G) (45875-84A, not included). Coat fork oil seal ID with clean fork oil. With the lip garter spring side facing down (toward the fork slider), slide oil seal down fork tube until it contacts slider spacer (H).

13. See Figure 2. Obtain the FORK OIL SEAL INSTALLER (HD-34634) and proceed as follows:
 - a. Slide the fork seal installer down the fork tube until it contacts the fork oil seal.
 - b. See Figure 3. Using the tool like a slide hammer, drive fork oil seal (with slider spacer and guide bushing) down the fork tube until retaining clip groove is visible in fork slider ID.
 - c. See Figure 6. Slide the retaining clip (F) down the fork tube until it contacts the fork oil seal. Install retaining clip in the fork slider groove. Do not expand or stretch retaining clip to install on fork tube or clip may become bent or distorted.
14. Remove fork spring from fork tube.
15. With the fork tube topside, clamp fork slider (not the fork tube) into fork tube holder.

NOTE

Install the new drain screw at the bottom of the fork slider, if removed. Tighten the screw to 72-96 in-lbs (8-11 Nm).

16. Pour 375 ml of Harley-Davidson Type E Fork Oil into fork tube.
17. Pump fork tube 10 times to remove air from system.

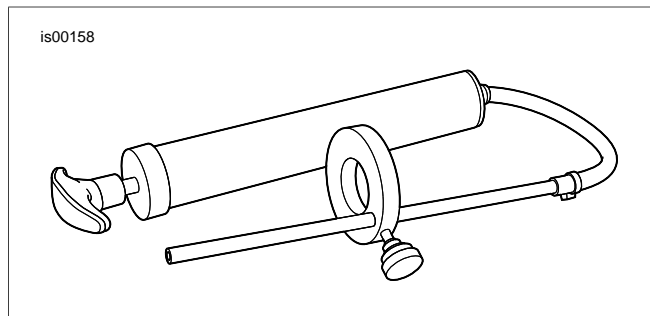

Figure 4. Front Fork Oil Level Gauge (HD-59000B)

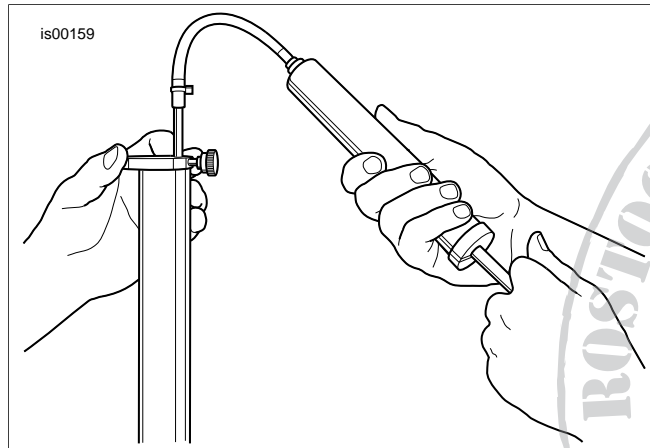

Figure 5. Remove Excess Fork Oil

18. Adjust the fork oil level, so that it is 6.34 inches (161 mm) from the top of the fork tube with the fork tube compressed and the main spring removed. Proceed as follows:
 - a. See Figure 4. Obtain the FRONT FORK OIL LEVEL GAUGE (Part Number HD-59000B).
 - b. Loosen thumbscrew on metal ring and move it up or down the rod until the bottom of the ring is 6.34 inches (161 mm) from the bottom of the rod. Tighten thumbscrew.
 - c. Push the handle on the cylinder all the way in.
 - d. See Figure 5. Insert rod into top of fork tube until metal ring rests flat on top of fork tube.
 - e. Pull out handle to suck fork oil from fork tube. Observe fork oil through transparent tube as it is drawn into cylinder.
 - f. Remove rod from fork tube. Push handle into cylinder to eject excess fork oil into suitable container.
 - g. If necessary, repeat Steps 18(c) through 18(f). Level is correct when no fork oil is observed being drawn through transparent tube.
19. Install fork spring into the fork tube with the dense end down.

NOTE

Do NOT overtighten or O-ring damage may occur.

20. Install new O-ring (C) (45845-77, not included) onto fork tube plug (B). Compressing fork spring with end of fork tube plug, thread fork tube plug into fork tube. Tighten fork tube plug to 22-59 ft-lbs (30-79 Nm).
21. Install new quad ring seal (4) (45733-48) onto fork cap bolt. Thread fork cap bolt (A) into fork tube plug to prevent loss of fork oil while handling.
22. Loosely install axle cap (S), flat washers (P), lockwashers (Q) and nuts (R) on studs at end of fork slider.
23. Repeat steps 1 thru 21 for left side fork assembly.

Fork Installation

1. Remove fork cap bolt from front fork.
2. Refer to the appropriate Service Manual and install the front forks on the motorcycle.

WARNING

Whenever a wheel is installed and before moving the motorcycle, pump brakes to build brake system pressure. Insufficient pressure can adversely affect brake performance, which could result in death or serious injury. (00284a)

3. Pump brakes prior to test ride.
4. Test ride the vehicle to ensure proper fork travel and rebound.

SERVICE PARTS

is04020

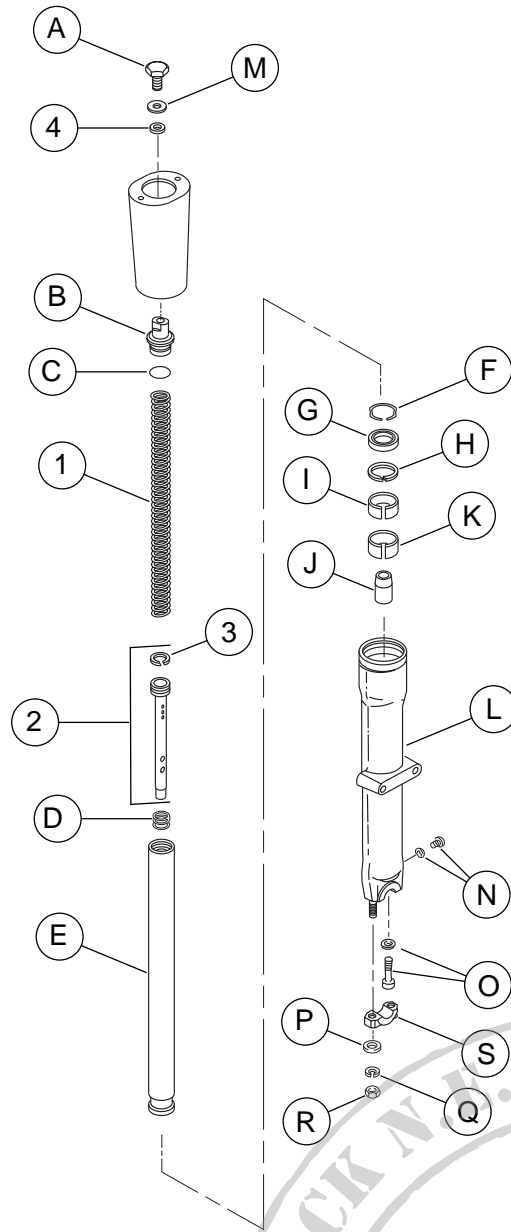

Figure 6. Service Parts: FL Softail Front Lowering Suspension Kit

Table 1. Service Parts Table

Item	Description (Quantity)	Part Number
1	Fork spring (2)	46100-05
2	Damper tube (2)	45796-05
3	Ring, damper tube (2) (included with item 2, damper tube)	45859-77A
4	Quad ring seal (2)	45733-48

Table 2. Parts Mentioned In Instruction Sheet, But Not Included In Kit

Item	Description (Quantity)	Item	Description (Quantity)
A	Fork cap bolt	K	Bushing
B	Fork plug	L	Slider, fork
C	O-ring	M	Spacer
D	Rebound spring	N	Drain screw
E	Slider tube	O	Screw with washer
F	Retaining ring	P	Washer
G	Oil seal	Q	Lock washer
H	Spacer, seal	R	Nut
I	Bushing, slider	S	Axle cap
J	Stop, oil lock		

See the appropriate Parts Catalog for a complete list of front fork service part numbers.

