



INSTRUCTIONS

-J04755

REV. 2008-08-26

TOURING FRONT LOWERING KIT

GENERAL

Kit Number

54564-09

Models

For model fitment information, see the P&A Retail Catalog or the Parts and Accessories section of www.harley-davidson.com (English only).

Additional Parts Required

WARNING

This kit is not designed to be used with Sidecar installed. Any attempt to use this front suspension kit with sidecar can adversely affect stability and handling. (00430b)

WARNING

This Front End Lowering Kit cannot be used independently. It must be used with an appropriate Low Rear Suspension Kit or handling and cornering can be affected, which could distract the rider, causing loss of control and death or serious injury. (00429b)

Proper installation of this kit requires, except FLHX, installation of an FL Profile Low Rear Suspension Kit (54635-09).

Proper installation of this kit also requires the following special tools: Fork Tube Holder (HD-41177), Fork Seal/Bushing Tool (HD-34634) and Front Fork Oil Level Gauge (HD-59000B).

Proper installation of this kit may also require the replacement of the following parts:

Table 1. Replacement Parts

Item (Quantity)	Part Number
O-ring (2)	45845-77
Quad ring seal (2)	45733-48
Wear ring (2)	45859-77A
Slider bushing (2)	45940-84
Fork oil seal (2)	45875-84A
Screw with copper crush washer, 6 mm (2)	45405-75A
Harley-Davidson® Fork oil	99884-80

WARNING

The rider's safety depends upon the correct installation of this kit. Use the appropriate service manual procedures. If the procedure is not within your capabilities or you do not have the correct tools, have a Harley-Davidson dealer perform the installation. Improper installation of this kit could result in death or serious injury. (00333a)

NOTE

This instruction sheet references service manual information. A service manual for your model motorcycle is required for this installation and is available from a Harley-Davidson Dealer.

Kit Contents

See Figure 6 and Table 2.

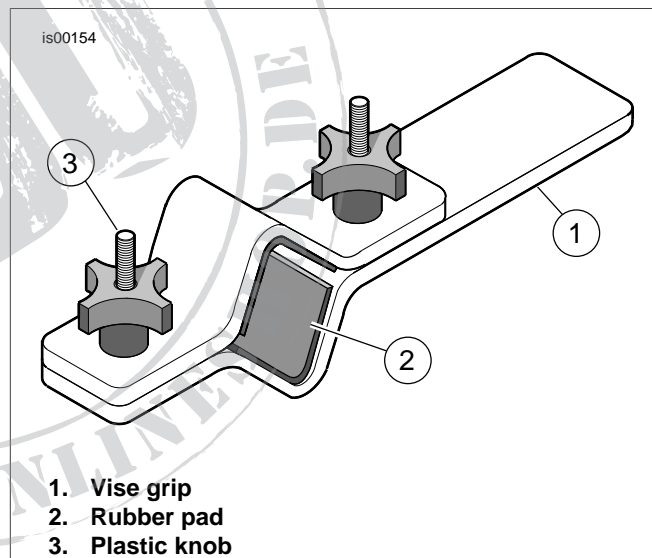

Figure 1. Fork Tube Holder (HD-41177)

REMOVAL

1. Refer to the appropriate service manual and remove the front fender, wheel and brakes.
2. Refer to the appropriate service manual and remove the front forks.

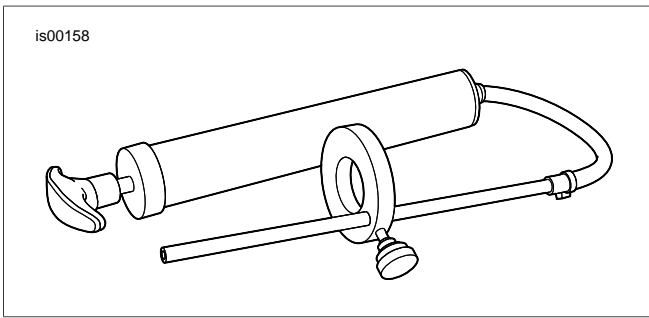

Figure 2. Front Fork Oil Level Gauge (HD-59000B)

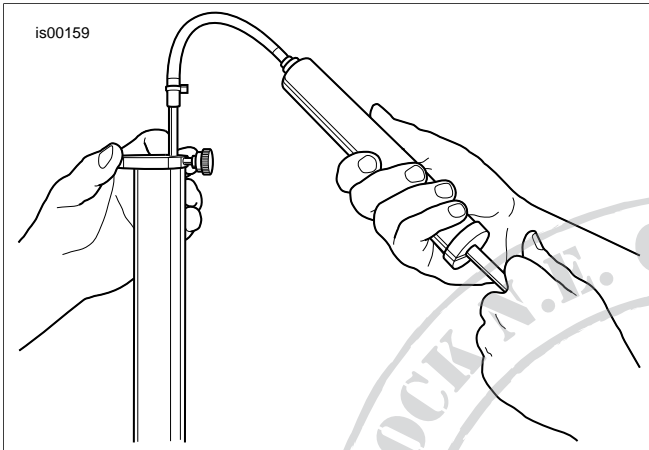

Figure 3. Remove Excess Fork Oil

WARNING

Incorrect amount of fork oil can adversely affect handling and lead to loss of vehicle control, which could result in death or serious injury. (00298a)

INSTALLATION

Right Side and Left Side Fork Disassembly

1. Obtain right fork assembly removed in earlier step.
2. See Figure 6. Remove nuts (U), lockwashers (T), flat washers (S) and axle holder (R) from studs at end of fork slider (O).
3. See Figure 1. Install fork in Fork Tube Holder (HD-41177) as follows:
 - a. Clamp end of tool (1) in vise in a horizontal position.
 - b. With the fork cap bolt topside, clamp fork tube between rubber pads (2) on inboard side of tool. Tighten knobs (3) until fork tube is securely held.

WARNING

Wear safety glasses or goggles when servicing fork assembly. Do not remove slider tube caps without relieving spring preload or caps and springs can fly out, which could result in death or serious injury. (00297a)

NOTE

Refer to Figure 6 for Steps 4 - 16.

4. Remove fork cap bolt (A) from fork plug. Remove quad ring seal (D). Save bolt but discard quad ring seal.

5. Slowly remove fork plug (B) from fork tube (G). Be aware that fork plug is under spring-pressure, so have a firm grasp on plug as the last thread is turned.

WARNING

Wear safety glasses or goggles when removing or installing spring. Spring tension can cause spring, attached components and/or hand tools to fly out which could result in death or serious injury. (00477c)

6. Remove the fork spring (1) from the fork tube.
7. Remove fork assembly from fork tube holder. Turn fork upside down and drain fork oil into drain pan. For best results, slowly pump fork tube and slider at least 10 times.
8. Install fork spring back into fork tube.
9. Put a shop rag on the floor. Turn the fork assembly upside down and press the end of the spring against the rag. Compress the spring and remove the screw (Q) from end of fork slider (O or N). Use air impact wrench for best results. Discard screw (Q) and copper crush washer.
10. Remove fork spring (1), blow valve (E) and damper tube (2) from fork tube. Discard fork spring and save blow valve.
11. Remove and save rebound spring (F) from damper tube. Discard damper tube.
12. Using pick tool, remove retaining ring (H) between fork slider (O) and slider tube (G). Do not expand or stretch retaining clip to remove from fork tube or clip may be damaged.

NOTE

To overcome any resistance, use the fork tube as a slide hammer: Push fork tube into fork slider and then pull it outward with a moderate amount of force. Repeat this sequence until fork tube separates from fork slider.

13. Remove fork tube from fork slider.
14. Slide fork oil seal (I), seal spacer (J) and bushing (M) off end of fork tube. Discard fork oil seal and bushing.
15. Gently pry at split line to expand slider bushing (K), and then remove from groove at end of fork tube. Discard slider bushing.
16. Remove the oil lock stop (L) from the fork slider.

Right Side and Left Side Fork Assembly

CAUTION

Exercise caution to avoid scratching or nicking fork tube. Damaging tube can result in fork oil leaks after assembly. (00421b)

NOTES

Clean all components and inspect for wear.

Refer to Figure 6 for the following procedure.

1. Coat new bushing (45866-84, not included) ID with clean fork oil. Expand bushing at split line only so far as required to slip over end and into groove of fork tube.
2. Obtain new damper tube (2). If necessary, install new wear ring (V, 45859-77A, not included) in groove at top of new

damper tube. Install rebound spring (F) and install on opposite end of damper tube.

3. With the wear ring topside, slide new damper tube (2) into fork tube, so that tube end drops through hole at bottom of fork tube (H). Install oil lock stop (L) at end of damper tube.
4. Install fork slider (O or N) in fork tube holder. Slide fork tube into fork slider.
5. Coat bushing (M) ID with clean fork oil. Slide bushing down fork tube.
6. Slide seal spacer (J) down fork tube until it contacts bushing.

NOTE

Place masking tape over edge of fork tube to avoid damaging lip of fork oil seal during installation.

7. Coat the new fork oil seal (I, 45875-84A, not included) ID with clean fork oil. With the lip of garter spring side facing down (toward the fork slider), slide fork oil seal (I) down fork tube until it contacts the slider spacer. Remove masking tape from edge of fork tube.

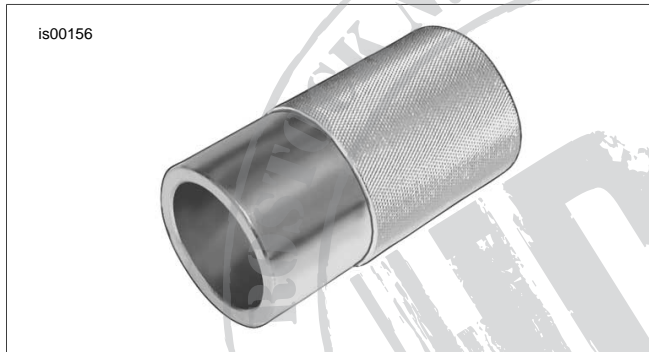

Figure 4. Fork Seal/Bushing Tool (HD-34634)

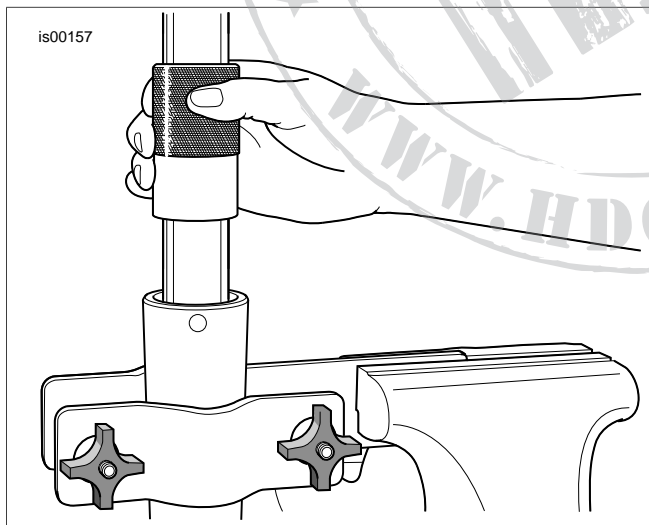

Figure 5. Install Fork Oil Seal

8. See Figure 4. Obtain the Fork Seal/Bushing Tool (HD-34634) and proceed as follows:

- a. Slide the fork seal installer down the fork tube until it contacts the fork oil seal.
- b. See Figure 5. Using the tool like a slide hammer, drive fork oil seal (with slider spacer and guide bushing) down the fork tube until retaining clip groove is visible in fork slider ID.
- c. Slide the retaining ring (H) down the fork tube until it contacts the fork oil seal. Install retaining clip in the fork slider groove. Do not expand or stretch retaining clip to install on fork tube or clip may become bent or distorted.

9. Install blow valve (E).

NOTE

Verify the fork spring is installed with dense section of coils to the bottom.

10. Obtain new fork spring (1). Install fork spring into fork tube.
11. Remove fork assembly from fork tube holder.
12. Place a shop rag on the floor, turn fork assembly upside down and press end of spring against rag.
13. Install new screw (Q) with copper crush washer (45405-75A, not included). Slide screw through hole at bottom of fork slider (O or N) and start into end of damper tube.
14. While compressing spring to prevent rotation of damper tube, tighten the screw to 11-18 ft-lbs (15-24 Nm).
15. Remove fork spring from fork tube.
16. With the fork tube topside, clamp fork slider (not the fork tube) into fork tube holder.

NOTE

Install the drain screw (P) at the bottom of the fork slider, if removed. Tighten the screw to 72-96 in-lbs (8-11 Nm).

17. Pour 11.2 ounces (330 ml) of Harley-Davidson Type E Fork Oil into the fork tube. Pump fork tube until some resistance is felt then pump a few more times to remove air from system.
18. Adjust the fork oil level, so that it is 4.92 inches (125 mm) from the top of the fork tube with the fork tube compressed,

blow valve installed, and the main spring removed. Proceed as follows:

- a. See Figure 2. Obtain the Front Fork Oil Level Gauge (Part Number HD-59000B).
 - b. Loosen thumbscrew on metal ring and move it up or down the rod until the bottom of the ring is 4.92 inches (125 mm) from the bottom of the rod. Tighten thumbscrew.
 - c. Push the handle on the cylinder all the way in.
 - d. See Figure 3. Insert rod into top of fork tube until metal ring rests flat on top of fork tube.
 - e. Pull handle to remove fork oil from fork tube. Observe fork oil through transparent tube to verify oil is being drawn from cylinder.
 - f. Remove rod from fork tube. Push handle into cylinder to eject excess fork oil into suitable container. Dispose of waste properly.
 - g. If necessary, repeat Steps 18(c) through 18(f). Level is correct when no fork oil is observed being drawn through transparent tube.
19. Install fork spring into the fork tube with the dense end down.

NOTE

Do NOT overtighten or O-ring damage may occur.

20. Install new O-ring (C, 45845-77, not included) onto fork plug (B). Thread fork plug into fork tube while compressing fork spring with end of fork plug. Tighten fork plug to 22-59 ft-lbs (30-79 Nm).

21. Install new quad ring seal (D) (45733-48, not included) onto fork cap bolt. Thread fork cap bolt (A) into fork tube plug to prevent loss of fork oil while handling.

22. Repeat steps 1-21 for other fork.

Fork Installation

1. Remove fork cap bolt from front fork.
2. Refer to the appropriate service manual and install the front forks.

⚠ WARNING

After repairing the brake system, test brakes at low speed. If brakes are not operating properly, testing at high speeds can cause loss of control, which could result in death or serious injury. (00289a)

⚠ WARNING

Whenever a wheel is installed and before moving the motorcycle, pump brakes to build brake system pressure. Insufficient pressure can adversely affect brake performance, which could result in death or serious injury. (00284a)

3. Refer to the appropriate service manual and install the front fender, wheel and brakes.
4. Pump brakes to build system pressure.

Test Ride

1. Test ride motorcycle to verify proper fork travel and rebound.

SERVICE PARTS

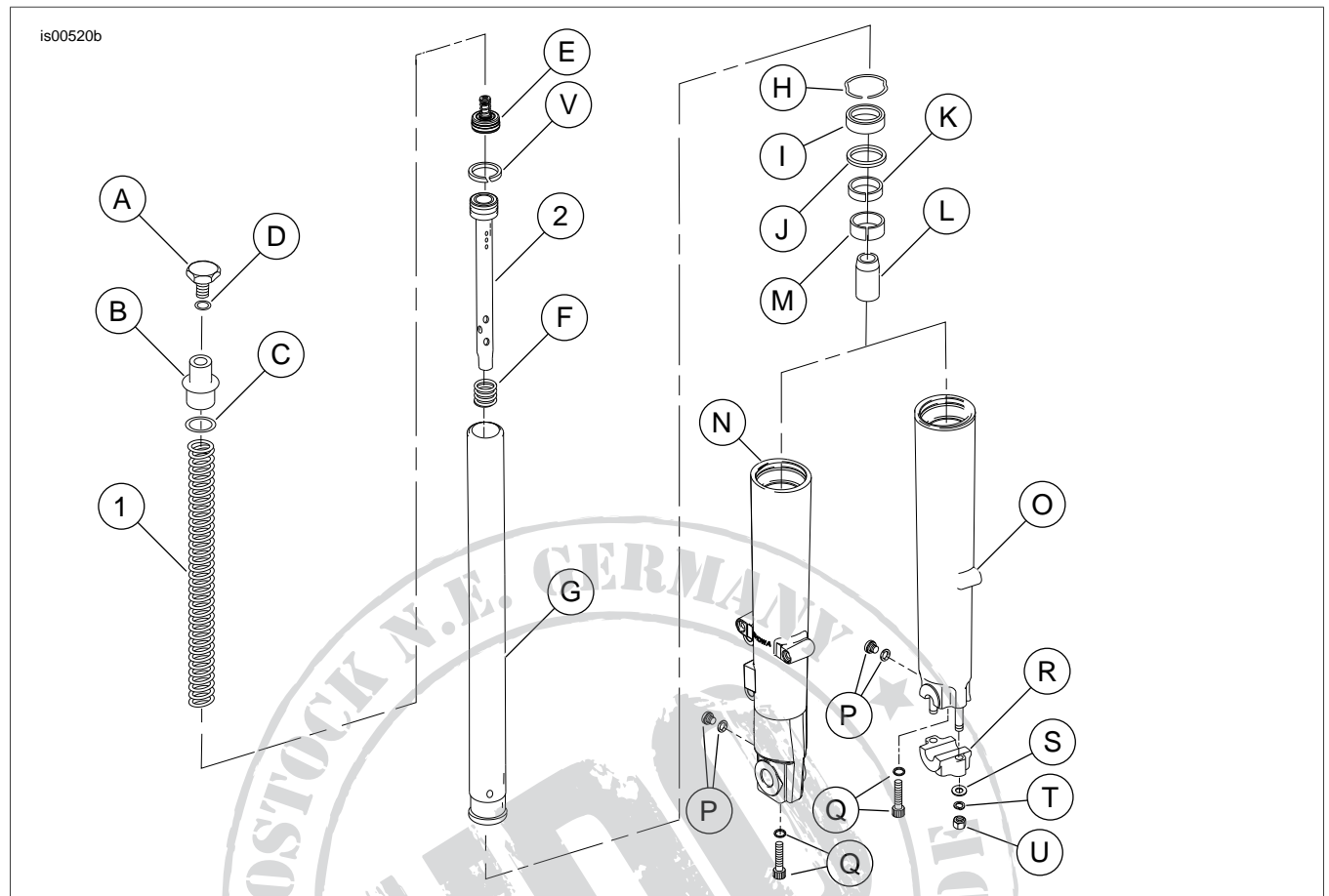

Figure 6. Service Parts: Touring Front Lowering Kit

Table 2. Service Parts Table

Item	Description (Quantity)	Part Number
1	Fork spring (2)	Not Sold Separately
2	Damper tube	Not Sold Separately

Table 3. Service Parts Table

Item	Description (Quantity)	Item	Description (Quantity)
A	Fork cap bolt	L	Stop, oil lock
B	Fork plug	M	Bushing
C	O-ring	N	Slider, fork (left side)
D	Quad ring seal	O	Slider, fork (right side)
E	Blow valve	P	Drain screw
F	Rebound spring	Q	Screw with washer
G	Slider tube	R	Axle holder
H	Retaining ring	S	Washer
I	Oil seal	T	Lock washer
J	Spacer seal	U	Nut
K	Bushing, slider	V	Wear ring