



# INSTRUCTIONS

-J04394

REV. 2011-06-30

## TOURING SEATS

### GENERAL

#### Kit Number

51615-09, 51630-09, 51729-09, 52000003, 52000026, 52067-08, 52093-08, 52095-08, 52099-09, 52619-08, 53051-09, 54382-11, 54383-11

#### Models

For model fitment information, see the P&A Retail Catalog or the Parts and Accessories section of [www.harley-davidson.com](http://www.harley-davidson.com) (English only).

#### Kit Contents

See Figure 5 and Table 2 for complete kit contents. See Table 1 for the grab strap part number associated with each seat kit.

Table 1. Kit Numbers and Grab Strap Usage

Kit Number	Grab Strap	Kit Number	Grab Strap
51615-09	51680-07	52095-08	53031-05
51630-09	51680-07	52099-09	51176-96C
51729-09	51188-86	52619-08	51680-07
52000003	52400005	53051-09	52000-09
52000026	52400009	54382-11	51680-07
52067-08	69142-05	54383-11	51680-07
52093-08	51680-07		

### WARNING

The rider's safety depends upon the correct installation of this kit. If the procedure is not within your capabilities or you do not have the correct tools, have a Harley-Davidson dealer perform the installation. Improper installation of this kit could result in death or serious injury. (00308a)

### REMOVAL

#### NOTE

Cover painted surfaces with protective material to prevent scratches or other damage.

1. Remove the left and right side saddlebags from the motorcycle per the instructions in the owner's manual. Save all hardware for installation.

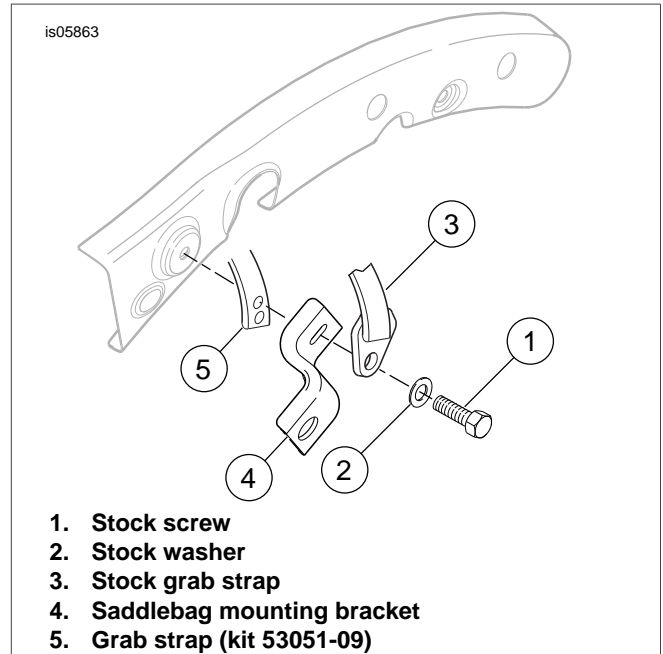

Figure 1. Remove Grab Strap and Install Kit 53051-09

#### NOTE

Before removing the saddlebag mounting bracket attaching bolts, note the mounting orientation of the saddlebag mounting brackets.

2. See Figure 1. Remove the **left side** screw (1) and washer (2) to remove the bracket (4) and the passenger grab strap (3).  
Repeat for the right side saddlebag mounting bracket.
3. See Figure 5. Remove the screw with lockwasher (A) from the rear of the currently installed seat. Pull the seat rearward to remove the seat from the motorcycle. Save the screw.
4. **For All Kits Except 53051-09:** Remove the two flanged nuts (B) from the studs (C) near the front of the rear fender.

5. If equipped, remove fender trim strips:
  - a. Cover the tip of a regular screwdriver with a piece of tape to protect chrome and painted surfaces.
  - b. See Figure 2. Insert the tip of the screw driver between the chrome bezel and the rubber trim strip.
  - c. Pry up the bezel enough to get a hold of it, then pull it up and away from the rubber trim strip.
  - d. Starting at either end, peel the rubber trim strip away from the fender.
  - e. Clean any remaining adhesive off of the fender using an approximately 1:1 solution of distilled water and isopropyl alcohol.

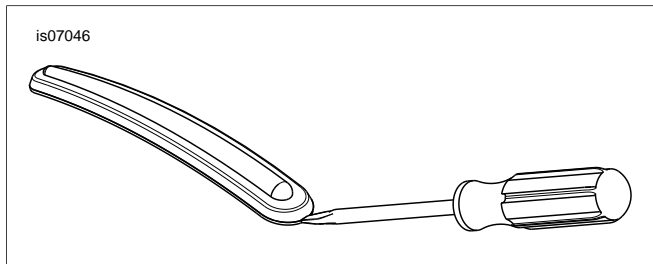

Figure 2. Remove Fender Trim Strip

## INSTALLATION

### For All Kits Except 53051-09:

1. Install the grab strap (2) onto the studs as shown in Figure 3. Secure the grab strap to the studs with the nuts, and tighten to 96-156 **in-lbs** (11-18 Nm).
2. See Figure 4. Slide the rear of the seat through the grab strap, from the front, until the slot (2) on the front underside of the seat is behind the seat mounting tongue (1) on the fuel tank rear bracket.
3. Press the seat down onto the frame backbone. Slide the seat toward the front of the motorcycle until the fuel tank bracket tongue fully engages into the slot under the seat.

### WARNING

**After installing seat, pull upward on seat to be sure it is locked in position. While riding, a loose seat can shift causing loss of control, which could result in death or serious injury. (00070b)**

4. Secure the seat onto the rear fender with the screw and lockwasher removed earlier.  
Tighten the screw to 4-6 ft-lbs (5.4-8.1 Nm)

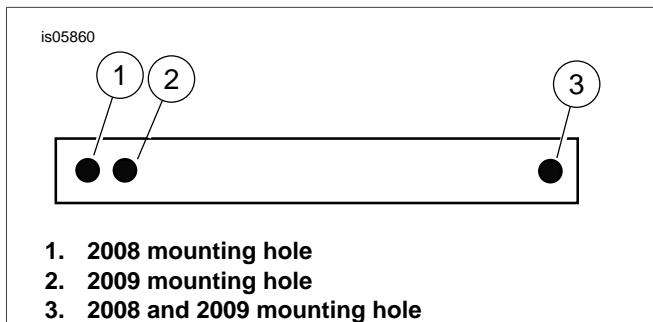

Figure 3. Grabstrap for Kit 53051-09

### For Kit 53051-09:

1. See Figure 4. Install the seat until the slot (2) on the front underside of the seat is behind the seat mounting tongue (1) on the fuel tank rear bracket.
2. Press the seat down onto the frame backbone. Slide the seat toward the front of the motorcycle until the fuel tank bracket tongue fully engages into the slot under the seat.

### WARNING

**After installing seat, pull upward on seat to be sure it is locked in position. While riding, a loose seat can shift causing loss of control, which could result in death or serious injury. (00070b)**

3. Secure the seat onto the rear fender with the screw and lockwasher removed earlier.  
Tighten the screw to 4-6 ft-lbs (5.4-8.1 Nm).
4. See Figure 1. Install the grab strap behind the saddlebag mounting bracket (4). Use the grab strap mounting holes as shown in Figure 3.
5. Tighten stock screws to 15-20 ft-lbs (20-27 Nm).

### For All Models

#### NOTE

*The molded rubber insert at the bottom of the saddlebags must fit snugly on the lower saddlebag support rails.*

6. Install the saddlebags to the motorcycle per the instructions in the owner's manual. Secure with the original bail head studs and flat washers.
7. Tighten the forward saddlebag mounting bolts to 60-96 **in-lbs** (7-11 Nm).



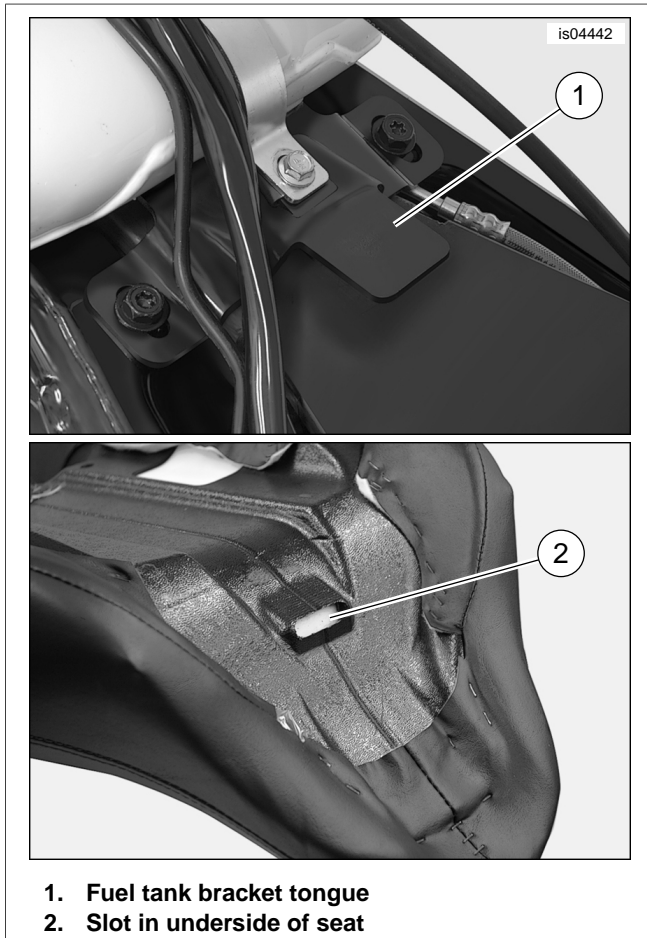

Figure 4. Seat Front Mounting



# SERVICE PARTS

is05442

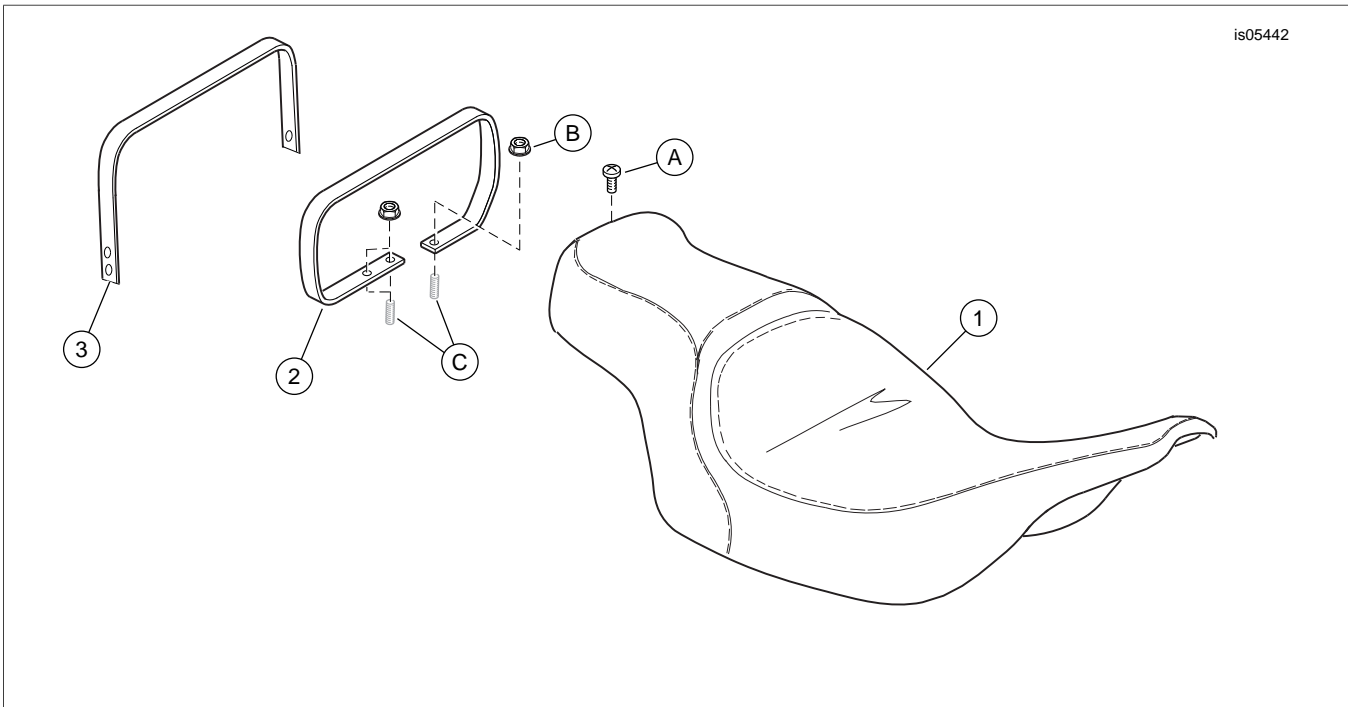

Figure 5. Service Parts, FL Touring Seats

Table 2. Service Parts Table

Item	Description (Quantity)	Part Number
1	Seat (plain pattern shown)	Not sold separately
2	Grab strap (for all kits except 53051-09)	See Table 1
3	Grab strap (kit 53051-09)	See Table 1
4	Leather dressing (not shown)	Not sold separately
<b>Items mentioned in text, but not included in kit:</b>		
A	Original equipment (OE) Phillips-head screw	
B	OE flanged nut (2)	
C	OE stud (2)	

