



INSTRUCTIONS

-J05265

REV. 2010-10-30

TURN SIGNAL RELOCATION KIT

GENERAL

Kit Number

54296-11

Models

For model fitment information, see the P&A Retail Catalog or the Parts and Accessories section of www.harley-davidson.com (English only).

Additional Parts and Tools Required

Separate purchase and installation of additional parts or accessories may be required for proper installation of this kit on your model motorcycle. See the P&A Retail Catalog or the Parts and Accessories section of www.harley-davidson.com (English only) for a list of required parts or accessories for your model.

Separate purchase of LOCTITE® 243 Threadlocker and Sealant - Blue (99642-97) is required for proper installation of this kit. LOCTITE can be purchased from any Harley-Davidson Dealer.

If installing this kit on a model with sealed LED rear turn signals, separate purchase of two turn signal recess covers (Part No. 68749-09).

Separate purchase of crimping tool (HD-38125-8 or equivalent) is required for proper installation of this kit.

⚠ WARNING

The rider's safety depends upon the correct installation of this kit. Use the appropriate service manual procedures. If the procedure is not within your capabilities or you do not have the correct tools, have a Harley-Davidson dealer perform the installation. Improper installation of this kit could result in death or serious injury. (00333a)

NOTE

This instruction sheet references service manual information. A service manual for your model motorcycle is required for this installation and is available from a Harley-Davidson dealer.

Kit Contents

See Figure 1 and Table 1.

REMOVAL

1. See the service manual and remove the seat.

⚠ WARNING

To prevent accidental vehicle start-up, which could cause death or serious injury, remove main fuse before proceeding. (00251b)

2. See the service manual and remove the main fuse.
3. See the service manual. Locate the rear lighting connectors on the right side of the seat pan area. Disconnect rear lighting connectors from the main wiring harness:
 - a. Disconnect the right Stop/Tail/Turn connector [18B] from main wiring harness connector [18A].
 - b. Disconnect the left Stop/Tail/Turn connector [19B] from main wiring harness connector [19A].
 - c. Disconnect the license plate lamp connector [40B] from main wiring harness connector [40A].
4. See the service manual and remove the rear fender assembly with fender struts attached and place it on a work surface.
5. See the service manual and Figure 1. Remove the socket terminals (10) from the 4-way socket housing (N).
6. Remove two screws (L) and screw (K) and remove the fender support (R) from the fender (Q).
7. Separate the Stop/Tail/turn harness (P) from the retaining clips (O).
8. Remove screw (H), washer (G), turn signal stalk (F) and assembled Stop/Tail/Turn lamp assembly from the fender support, pulling the harness out of the fender support and turn signal stalk. Save the washer for later installation and discard the screw and turn signal stalk.
9. **For models with incandescent turn signal bulbs and without saddlebags:**
 - a. Using a hobby knife or utility knife, carefully cut the conduit from the Stop/Tail/Turn wires.
 - b. Remove lens (A) from Stop/Tail/Turn housing (E). Remove bulb (B) from the socket of reflector (C).
 - c. Carefully pry the socket (C) and grommet (D) from the housing. The socket (C) and grommet (D) can be pressed out the housing (E) by inserting a small screwdriver into the harness hole of the housing (E) and prying gently against the back of the socket. Gently pull the wires from the housing.

INSTALLATION

Docking Point Installation with Saddlebags

NOTE

When the turn signal stalk retaining nut is installed, the cut groove face of the nut must face away from the fender strut.

The tab on the cover plate must face the fender strut.

The concave cutout of the cover plate is designed to fit with the docking point for the upright kit. If installing an upright kit, use the docking point from **that** docking hardware kit to properly orient the cover plate during installation.

1. See Figure 1. Install screw (7), washer (8), docking point (9) and cover plate (5) to rear hole of the fender support and secure with nut (6) and stock washer (G). Hold nut in place with a 3/8 inch hex key and tighten screw to 15 ft-lbs (20 Nm).
2. Clean the threads of screws (L) and (K) of any existing threadlocker.
3. Apply a small amount of Loctite 243 (blue) to screws (L), then install the fender support (R) to the fender (Q) and secure with fender bracket and screws. Do not tighten at this time.
4. Apply a small amount of Loctite 243 (blue) to screw (K) and install to fender (Q) and fender support (R).
5. Tighten screws (L and K) to 24 ft-lbs (32 Nm).
6. Repeat the Stop/Tail/Turn removal and docking point installation for the opposite side.

Docking Point Installation without Saddlebags for Incandescent Bulb Turn Signal

NOTES

When the turn signal stalk retaining nut is installed, the cut groove face of the nut must face away from the fender strut.

The tab on the cover plate must face the fender strut.

The concave cutout of the cover plate is designed to fit with the docking point for the upright kit. If installing an upright kit, use the docking point from **that** docking hardware kit to properly orient the cover plate during installation.

1. See Figure 1. Install the turn signal stalk (4), washer (8), docking point (9) and cover plate (5) into the rear mounting hole in the fender support. Secure the stalk to the fender support with nut (6) and stock washer (G). Do not tighten at this time.
2. Use a 3/8 inch hex key to rotate the nut (6), so that the outlet of the cut groove on the nut will face towards the front of the fender when the fender support is installed.
3. Hold nut in place with a 3/8 inch hex key and tighten the turn signal stalk to 15 ft-lbs (20 Nm).
4. Install jam nut (3) onto turn signal stalk (4) until it bottoms out on the threads, but do not tighten.
5. Install lockwasher (2) onto turn signal stalk (4).
6. Remove the socket terminals from the Stop/Tail/Turn harness by cutting the wires (P) immediately behind the socket terminals (10).

7. Place the recess cover (1) into position over the recess in the turn signal housing. Insert the wires from the socket through the grommet (D) into the turn signal housing (E), through the threaded hole and the recess cover, and into the turn signal stalk (4).

NOTE

Apply a drop of liquid soap to the wires to ease insertion through the stalk.

8. Route the wires through the turn signal stalk (4) until they are through the fender strut and nut (6).
9. Install the Stop/Tail/Turn housing onto the stud. Be careful that the wires are not twisted or damaged as the stalk and housing are assembled. The lockwasher will fit inside the hole in the recess cover. Hand-tighten the jam nut against the lockwasher.
10. While pulling the Stop/Tail/Turn wires, guide the turn signal socket and grommet into the housing.
11. Align the rear turn signal housing so that when the lens is installed it is aimed rearward for proper visibility. While holding the turn signal housing in position, tighten the jam nut against the lockwasher to 9 ft-lb (12 Nm).
12. Install the turn signal bulb (B) into the socket (C). Install the lens (A) in the turn signal housing (E).
13. Cut a length of the conduit that is necessary to cover the wires from the center of nut (6), allowing 1 in (25 mm) of wire protrusion. Install conduit over the wires.
14. Strip a 3/8 in (10 mm) section of insulation from the ends of the three wires.
15. See the service manual and install socket terminals (10) to the end of each wire.
16. See the service manual and install the socket terminals into the socket housing (N):
 - a. Install the Blue (BE) wire into cavity 1.
 - b. Install the Violet (V) wire into cavity 2.
 - c. Install the Black (BK) wire into cavity 4.
17. Route the wire harness through the retaining clips (O). It may be necessary to flatten the conduit for it to fit properly.
18. Clean the threads of screws (L) and (K) of any existing threadlocker.

NOTE

When installing the fender support to the fender, verify that the harness routes properly between the fender support (R) and fender (Q). If the harness is pinched, the wires may be cut or damaged.

19. Apply a small amount of Loctite 243 (blue) to screws (L), then install the fender support (R) to the fender (Q) and secure with fender bracket and screws. Do not tighten at this time.
20. Apply a small amount of Loctite 243 (blue) to screw (K) and install to fender (Q) and fender support (R).
21. Tighten screws (L and K) to 24 ft-lbs (32 Nm).
22. Repeat the Stop/Tail/Turn removal and docking point installation for the opposite side.

Docking Point Installation without Saddlebags for LED Turn Signal

NOTES

When the turn signal stalk retaining nut is installed, the cut groove face of the nut must face away from the fender strut.

The tab on the cover plate must face the fender strut.

*The concave cutout of the cover plate is designed to fit with the docking point for the upright kit. If installing an upright kit, use the docking point from **that** docking hardware kit to properly orient the cover plate during installation.*

1. See Figure 1. Install turn signal stalk (4), washer (8), docking point (9) and cover plate (5) to rear hole of the fender support and secure with nut (6) and stock washer (G). Hold nut in place with a 3/8 inch hex key and tighten turn signal stalk (4) to 15 ft-lbs (20 Nm).
2. Install jam nut (3) onto turn signal stalk (4) until it bottoms out on the threads, but do not tighten.
3. Install lockwasher (2) onto turn signal stalk (4).

NOTE

Installations for models with LED turn signals require the separate purchase of two recess covers (Part No. 68749-09).

4. Route the Stop/Tail/Turn harness through the small hole of the recess cover, then place the recess cover (1) into position over the recess in the turn signal housing.
5. Install the Stop/Tail/Turn housing onto the stud. The lockwasher will fit inside the hole in the recess cover. Hand-tighten the jam nut against the lockwasher.
6. Align the rear turn signal housing so that when the lens is installed it is aimed rearward for proper visibility. While holding the turn signal housing in position, tighten the jam nut against the lockwasher to 9 ft-lb (12 Nm).
7. Cut a 6 in (15 cm) section of conduit from the conduit (11) from the kit. Install the conduit over the gray harness of the Stop/Tail/Turn lamp and slide it all the way up to the recess cover.
8. See Figure 1, item (M). Remove the rear retaining clip (O) from the fender strut.
9. Route the wiring harness (P) along the turn signal stalk. Secure the harness to the turn signal stalk with a cable strap (S).
10. Route the wire harness to the fender side of the fender strut through the recess created by removing the rear retaining clip. Then route it through the front retaining clip (O). It may be necessary to flatten the conduit for it to fit properly.

11. See the service manual and install the wire harness socket terminals into the socket housing (N):
 - a. Install the White (W) wire into cavity 1.
 - b. Install the Green (GN) wire into cavity 2.
 - c. Install the Red (R) wire into cavity 3.
 - d. Install the Black (BK) wire into cavity 4.
12. Clean the threads of screws (L) and (K) of any existing threadlocker.

NOTE

When installing the fender support to the fender, verify that the harness routes properly between the fender support (R) and fender (Q). If the harness is pinched, the wires may be cut or damaged.

13. Apply a small amount of Loctite 243 (blue) to screws (L), then install the fender support (R) to the fender (Q) and secure with fender bracket and screws. Do not tighten at this time.
14. Apply a small amount of Loctite 243 (blue) to screw (K) and install to fender (Q) and fender support (R).
15. Tighten screws (L and K) to 24 ft-lbs (32 Nm).
16. Repeat the Stop/Tail/Turn removal and docking point installation for the opposite side.

FINAL ASSEMBLY

1. See the service manual and install the assembled rear fender.
2. Connect the rear harness connectors to the main harness:
 - a. Connect the right Stop/Tail/Turn connector [18B] to main wiring harness connector [18A].
 - b. Connect the left Stop/Tail/Turn connector [19B] to main wiring harness connector [19A].
 - c. Connect the license plate lamp connector [40B] to main wiring harness connector [40A].

WARNING

After installing seat, pull upward on seat to be sure it is locked in position. While riding, a loose seat can shift causing loss of control, which could result in death or serious injury. (00070b)

WARNING

Be sure that all lights and switches operate properly before operating motorcycle. Low visibility of rider can result in death or serious injury. (00316a)

3. Install main fuse, then install the seat and check the turn signals for proper operation.

SERVICE PARTS

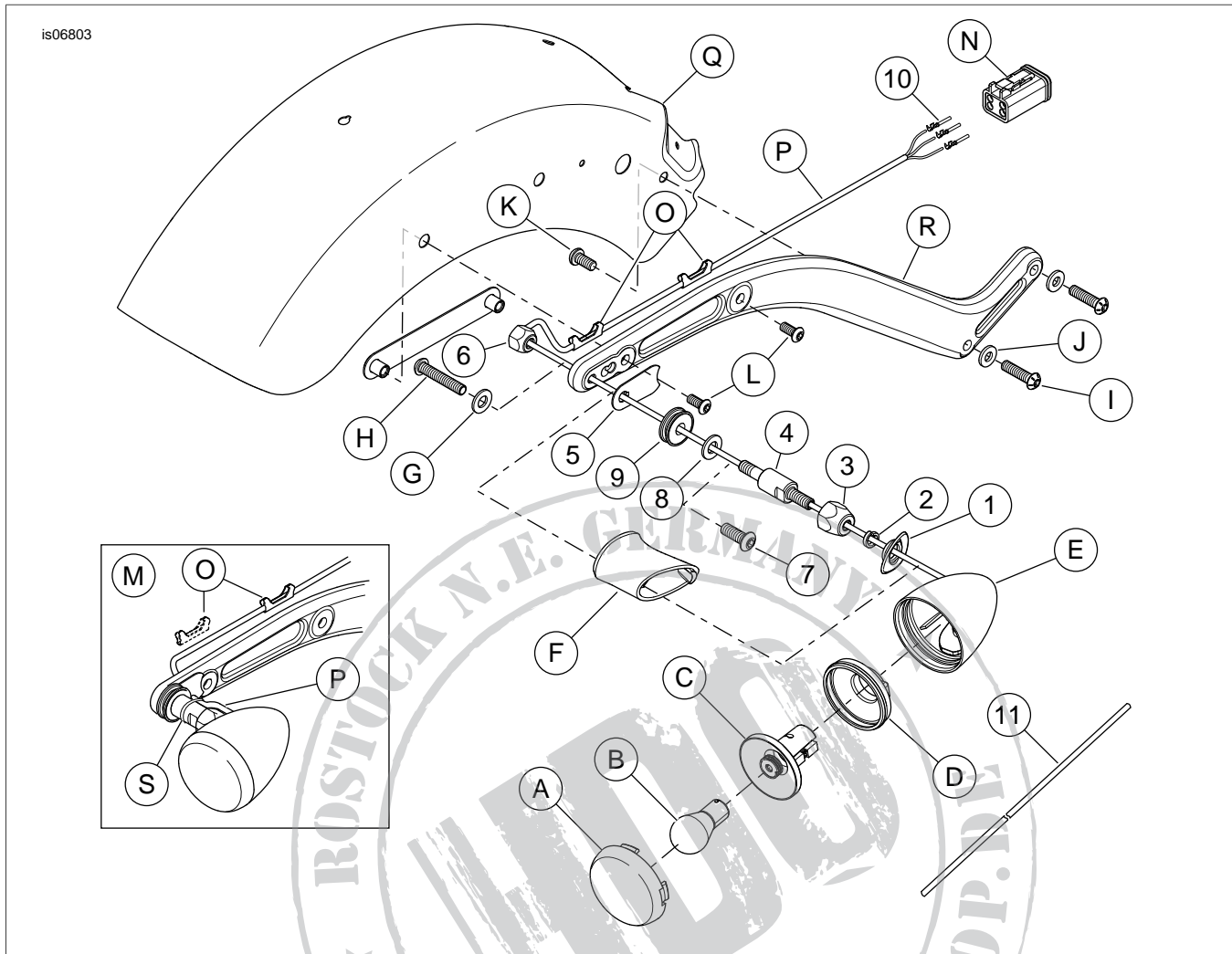

Figure 1. Service Parts: Turn Signal Relocation Kit

Table 1. Service Parts Table

Item	Description (Quantity)	Part Number
1	Recess cover, turn signal (2)	68864-10
2	Lockwasher, helical spring (2)	7042
3	Jam nut, turn signal stalk (2)	7344
4	Stalk, turn signal (2)	67800078
5	Cover plate (2)	12600013
6	Jam nut, special (2)	6983
7	Button head screw (2)	4359
8	Washer, plain (2)	6702
9	Bushing, docking point (2)	67621-94
10	Terminal, socket pin (8)	74191-98
11	Conduit	Not Sold Separately

Table 1. Service Parts Table

Item	Description (Quantity)	Part Number
Items mentioned in text, but not included in kit:		
A	Lens, turn signal (2)	
B	Bulb, turn signal (2)	
C	Socket, turn signal (2)	
D	Grommet (2)	
E	Housing, turn signal (2)	
F	Turn signal stalk, stock (2)	
G	Washer, plain (2)	
H	Screw, TORX (2)	
I	Screw, button head, TORX (4)	
J	Washer, plain (4)	
K	Screw, button head, TORX (2)	
L	Screw, button head, TORX (4)	
M	LED turn signal wiring harness routing	
N	4-Place connector housing, Deutsch (2)	
O	Clip, harness retaining (4)	
P	Wire harness (2)	
Q	Rear fender	
R	Fender support (2)	
S	Cable strap (2)	

