



INSTRUCTIONS

-J05072

REV. 2009-12-16

ADJUSTABLE AUXILIARY PASSENGER FOOTPEG MOUNT KIT

GENERAL

Kit Number

54157-10

Models

For model fitment information, see the P&A retail catalog or the Parts and Accessories section of www.harley-davidson.com (English only).

Additional Parts Required

Proper installation of this kit requires the installation of passenger footpegs.

See the P&A retail catalog or the Parts and Accessories section of www.harley-davidson.com (English only) for a selection of Genuine Motor Accessory footpegs that are available.

Tools and Supplies Required

If the passenger footboard supports are not currently installed in the middle position, Loctite® 243 Threadlocker and Sealant - Blue (H-D Part No. 99642-97) will be needed for proper installation. This item is available from a Harley-Davidson dealer.

Kit Contents

See Figure 1 and Table 1.

INSTALLATION

1. If the passenger footboards are currently installed in the upper or lower position, they must be moved to the middle position:
 - a. Remove the lower socket head shoulder bolt, and the upper socket head screw and lockwasher retaining the footboard bracket to the vehicle frame.
 - b. Remove the plastic plugs from the footboard bracket mounting holes in the frame, and reposition as necessary to allow proper footboard mounting.
 - c. When reusing the shoulder bolt and screw, apply a bead of Loctite 243 (blue) all the way around the threads of each. Install the bracket in the middle position.
 - d. Tighten the lower shoulder bolt to 48-72 **in lbs** (5.4-8.1 Nm).
 - e. Slide the footboard support to the middle position. Tighten the upper screw (and lockwasher) to 36-42 ft-lbs (48.8-56.9 Nm).
 - f. Repeat for the opposite side.

NOTE

The adjustable arms and lower clamps are side-specific. Both parts are marked with "LH" (left hand) or "RH" (right hand) to indicate their mounting on the vehicle.

2. See Figure 1. Disassemble the lower clamp (2) from the upper clamp (B) on the adjustable arm assembly (1).
3. Install the adjustable auxiliary passenger footpeg mount as follows:
 - a. Place the stop pad (3) onto the peg (F) of the lower clamp.
 - b. Position the lower clamp around the underside of the passenger footboard mount (C).
 - c. Insert the rib (G) of the lower clamp into the slot (D) in the underside of the passenger footboard mount.
 - d. Slide the lower clamp toward the motorcycle until the boss (H) on the lower clamp contacts the rib (E) on the underside of the passenger footboard mount.
 - e. Slide the lower clamp upward and hold it in place. Position the upper clamp over the passenger footboard mount and lower clamp.

NOTE

*For the right-side, one **short bolt** (5) installs in the single hole forward of the passenger footboard mount, and two **long bolts** (4) in the rearward holes.*

*For the left-side, three **short bolts** (5) are used.*

4. Install the lower clamp to the upper clamp with the bolts and lockwashers (6) as shown, but do not fully tighten.
5. Alternately tighten the bolts (4 and 5) to 15-18 ft-lbs (20.3-24.4 Nm), keeping the gap between the upper and lower clamps equal. **DO NOT** overtighten.
6. Wiggle the assembled footpeg mount to verify that it is solidly mounted, then again alternately check the bolts for tightness.
7. Repeat Steps 2 through 6 with the remaining adjustable footpeg mount on the opposite side of the vehicle.
8. See Adjustable Passenger Footpeg Mount Kit list in the catalog or on the website for specific footpeg fitments for this kit.

Proper installation of this kit requires the installation of passenger footpegs. Any H-D Genuine Motor Accessory footpeg with a tapered mounting shaft can be installed on these adjustable footpeg mounts.

H-D footpegs use either a long tapered mount or a short tapered mount.

If the footpeg selected uses the **long** tapered mount, first attach the footpeg adapter extension (7) and tighten to 17 ft-lbs (23 N-m).

For either the **long** or **short** tapered mount, slide the footpeg onto the shaft and rotate to the desired orientation. Refer to the footpeg instruction sheet for the proper torque.

IN USE

To adjust the pegs, retract the knob (I) of the sliding bolt, and rotate it into the slot. Move the adjustable arm forward or backward to the approximate desired position and release the sliding bolt. Move the adjustable arm forward or backward until the bolt snaps into place.

Alternately, the sliding bolt can be left in the slot, allowing the adjustable arm to freely rotate between the full forward and stowed position.

Check all fasteners (including pre-assembled) periodically to make sure they are tight before operation of the motorcycle.

⚠ WARNING

Do not adjust foot rest position while vehicle is in motion. This can distract the rider and lead to loss of control, which could result in death or serious injury. (00607c)

⚠ WARNING

Do not stand on adjustable foot pegs. Standing on foot pegs can bend or break them leading to a fall, which could result in serious injury. (00608c)

SERVICE PARTS

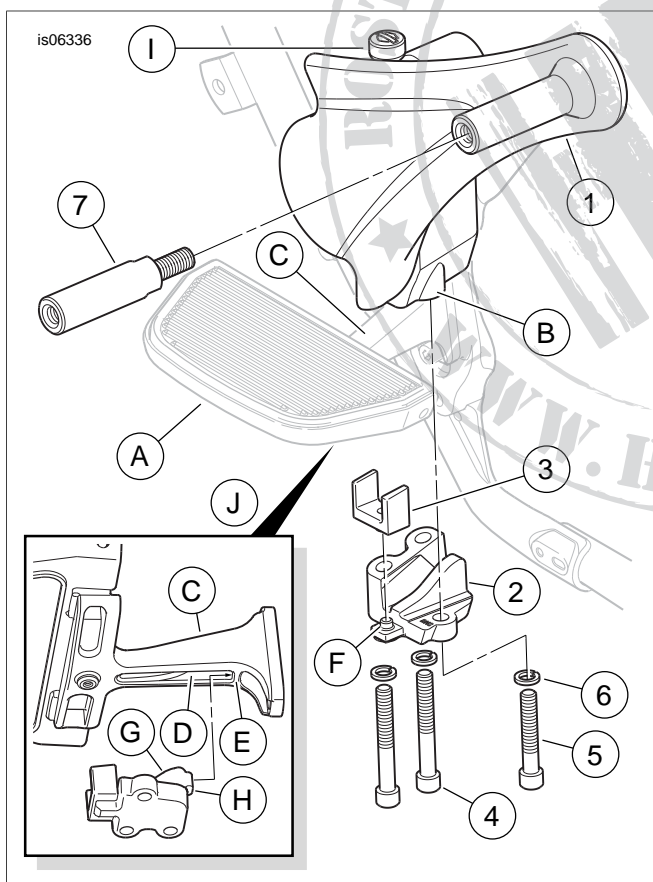

Table 1. Service Parts

Item	Description (Quantity)	Part Number
1	Arm, adjustable footpeg • Right side (shown) • Left side (not shown)	Not sold separately
2	Lower clamp, right (shown) Lower clamp, left (not shown)	Not sold separately
3	Stop pad (2)	54191-10
4	Bolt, long (2)	2253
5	Bolt, short (4)	2252
6	Lockwasher, split (6)	7042
7	Adapter, footpeg (2)	54279-10
Items mentioned in text, but not included in kit.		
A	Passenger footboard must be in middle position	
B	Upper clamp	
C	Footboard mount	
D	Slot in underside of footboard mount	
E	Rib on underside of footboard mount	
F	Lower clamp peg	
G	Lower clamp rib	
H	Lower clamp boss	
I	Sliding bolt knob	
J	View from underside of footboard	

Figure 1. Service Parts, Adjustable Auxiliary Passenger Footpeg Mount Kit (Right Side Shown)