



INSTRUCTIONS

-J06096

2014-05-28

PREMIUM RIDE, HAND-ADJUSTABLE TOURING SHOCKS

GENERAL

Kit Number

54000091

Models

For model fitment information, see the P&A Retail Catalog or the Parts and Accessories section of www.harley-davidson.com (English only).

Installation Requirements

Separate purchase of LOCTITE® 243 Threadlocker and Sealant - Blue (99642-97) for proper installation of this kit. Loctite is available from a Harley-Davidson dealer.

▲ WARNING

The rider's safety depends upon the correct installation of this kit. Use the appropriate service manual procedures. If the procedure is not within your capabilities or you do not have the correct tools, have a Harley-Davidson dealer perform the installation. Improper installation of this kit could result in death or serious injury. (00333a)

▲ WARNING

Installation of any accessory suspension components can affect cornering clearance. This could distract the rider, causing loss of control and death or serious injury. (00431b)

NOTE

This instruction sheet references service manual information. A service manual for your model motorcycle is required for this installation. One is available from a Harley-Davidson dealer.

Kit Contents

See Figure 3 and Table 1.

INSTALLATION

▲ WARNING

Use caution when bleeding air from the suspension. Moisture combined with lubricant may leak onto the rear wheel, tire and/or brake components and adversely affect traction, which could result in death or serious injury. (00084a)

NOTE

Both OE shocks must be removed before installing the shocks from this kit. To remove both shocks, place the motorcycle on a center stand with the rear wheel raised off the ground.

If you choose to save the air shocks, never lay the shock absorber down. Always keep the shock absorber upright to prevent oil from draining out through the compression fitting.

Any oil loss requires shock absorber replacement. The fitting can be sealed with a screw plug.

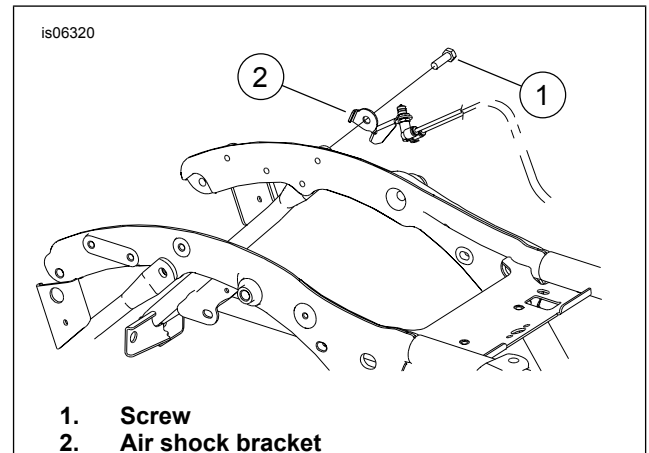

Figure 1. Remove Air Shock Bracket

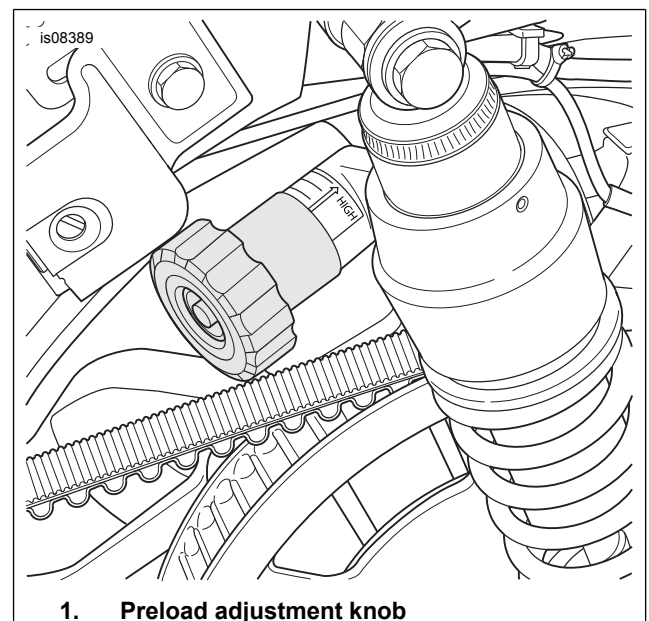

Figure 2. Preload Adjustment Knob

1. Refer to Rear Shock Absorbers in the service manual to remove the air suspension system and the air shocks.
2. See Figure 1. Remove the screw and assembly. Save the air valve bracket assembly if you plan to reuse the air shocks. Install the screw to the frame rail and saddlebag support and tighten to 20.3–27.1 N·m (15–20 ft·lbs). If wire harness is secured to air shock bracket with a cable strap, remove cable strap. Install a new cable strap around wire harness and saddlebag support.
3. Install the lockwasher to the lower shock bolt and then the flat washer. Apply Loctite 243 to the bolt threads.

- See Figure 3. Install the shock absorber (1) on the left side of the vehicle with the preload adjustment knob toward the front as shown in Figure 2. Start the bolt into the swingarm mount.
- Install lockwasher and flat washer to the upper shock bolt. Apply Loctite 243 to the thread bolts. Install upper shock bolt into frame.
- Tighten the upper and lower shock bolts to 47–54 N·m (35–40 ft-lbs).
- Repeat steps 3, 5 and 6 for the right side shock absorber, oriented as shown in Figure 3.

- Turn the knob half turns to fine tune the ride if desired.
- Install the left saddlebag if removed.

KIT CONTENTS

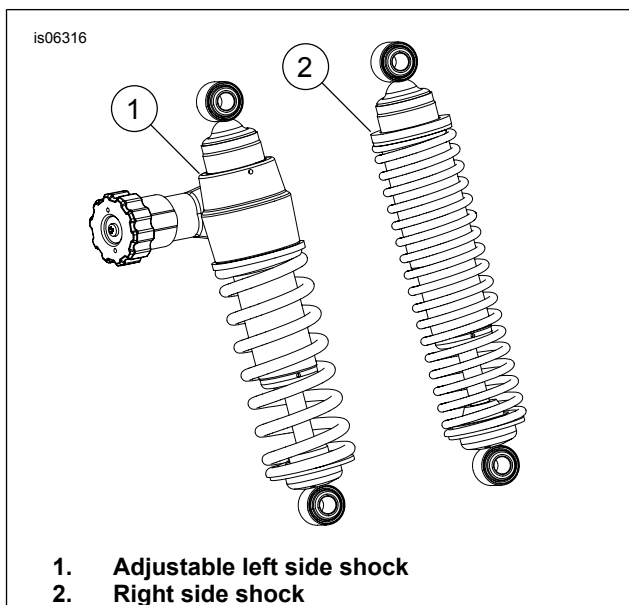

- Adjustable left side shock
- Right side shock

Figure 3. Adjustable Touring Shock Kit

NOTICE

Wipe all fingerprints off of exhaust system components after installation and before starting engine. Oil from hands can leave permanent marks on exhaust system finish. (00346a)

Shock Absorber Preload Adjustment

NOTE

The shock absorber preload can be adjusted for the weight the motorcycle is to carry. Increase preload to accommodate the total load. Reduce the preload if carrying less weight.

- Remove the left side saddlebag if installed.
- See Figure 2. Rotate the preload adjustment knob counterclockwise until it stops. This position is the minimum preload.
- Refer to Table 2 for models with Tour-Pak®. Refer to Table 3 for models without Tour-Pak. Rotate the preload adjustment knob clockwise the recommended number of turns to increase the preload for the total weight. This weight includes the rider, passenger, cargo and accessories. The knob will click after each half rotation.

Table 1. Service Parts: Adjustable Touring Shock Absorbers

Item	Description (Quantity)	Part Number
1	Shock absorber, left side	54000081
2	Shock absorber, right side	54000082

Table 2. Manual Suspension Preload Table: Models with Tour-Pak

		ADDITIONAL WEIGHT OF PASSENGER, CARGO AND ACCESSORIES																					
		LB	0	8	16	24	32	40	48	56	64	72	80	88	96	104	112	120	128	136	144	152	160
		KG	0	3.6	7.3	10.9	14.5	18.1	21.8	25.4	29.0	32.7	36.3	39.9	43.5	47.2	50.8	54.4	58.1	61.7	65.3	68.9	72.6
RIDER WEIGHT																							
LB	KG	Full Turns of Knob																					
150	68	0	1	2	3	4	5	6	7	8	9	10	11	12	13	14	15	16	17	18	HIGH		
160	72.6	1	2	3	4	5	6	7	8	9	10	11	12	13	14	15	16	17	18	HIGH			
170	77.1	2	3	4	5	6	7	8	9	10	11	12	13	14	15	16	17	18	HIGH				
180	81.6	3	4	5	6	7	8	9	10	11	12	13	14	15	16	17	18	HIGH					
190	86.2	4	5	6	7	8	9	10	11	12	13	14	15	16	17	18	HIGH						
210	95.3	5	6	7	8	9	10	11	12	13	14	15	16	17	18	HIGH							
220	99.8	6	7	8	9	10	11	12	13	14	15	16	17	18	HIGH								
230	104.3	7	8	9	10	11	12	13	14	15	16	17	18	HIGH									
240	108.9	8	9	10	11	12	13	14	15	16	17	18	HIGH										
250	113.4	9	10	11	12	13	14	15	16	17	18	HIGH											
260	117.9	10	11	12	13	14	15	16	17	18	HIGH												
270	122.5	11	12	13	14	15	16	17	18	HIGH													