



# INSTRUCTIONS

-J05536

2011-12-02

## SOFTAIL REAR SHOCK KIT

### GENERAL

#### Kit Number

54000041

#### Models

For model fitment information, see the P&A Retail Catalog or the Parts and Accessories section of [www.harley-davidson.com](http://www.harley-davidson.com) (English only).

#### Additional Parts and Tools Required

Snap-on<sup>®</sup> part number SRES-24 is necessary to gain access to the shock absorber bolts. When adding an adapter or extension to a torque wrench, bolt torque must be computed. A Torque Computer, part number SS-306G, is available from Snap-on. The computer is easy to use with dial- or click-type torque wrenches.

Loctite<sup>®</sup> 243 (blue) (99642-97)

Permatex<sup>®</sup> Anti-seize (98960-97)

#### Kit Contents

See Figure 1 and Table 1.

#### ⚠ WARNING

**Installation of any accessory suspension components can affect cornering clearance. This could distract the rider, causing loss of control and death or serious injury. (00431b)**

#### NOTE

*Rear shock absorbers on Softail models cannot be repaired. If a shock absorber becomes damaged, it must be replaced.*

### REMOVAL

1. Place motorcycle on a lift and secure front wheel.
2. Use an overhead crane or hoist to lift the rear of the motorcycle. Attach to the frame or rear fender area to allow the rear fork to travel.
3. Place a screw jack under the rear wheel to support and adjust the rear fork during shock absorber removal and installation.

#### ⚠ WARNING

**When supporting motorcycle, do not place supports under rear brake pedal. Damage to the brake system can occur, which could result in death or serious injury. (00100a)**

#### ⚠ WARNING

**Be sure rear wheel is supported when removing rear shocks. If wheel is not supported rear fork can drop down, which could result in death or serious injury. (00481b)**

4. See Figure 1. Remove stock bolt (A) and washer (B) that fasten each shock absorber (1) to rear fork (C). Save for later use.
5. Remove flanged locknut (2) and washer/grommet assembly (3) fastening each shock absorber (1) to frame crossmember (D). Discard shock absorber and attaching hardware from threaded end of shock.

### INSTALLATION

1. See Figure 1. Remove flange nut (2) and outer washer/grommet (3) from the rear shock absorber (1). Leave bushing (4) and inner washer/grommet (5) on shock absorber shaft.
2. Insert shock absorber shaft through frame crossmember (D).
3. Slip outer washer/grommet (3) onto the shock absorber shaft (grommet side first), and loosely fasten with flange nut (2). Check that washer/grommet properly fit hole in frame crossmember. Do not tighten at this time.
4. Repeat Steps 1-3 for other shock absorber.
5. Align shock absorber eye with rear fork mount (E) by adjusting rear wheel height with screw jack.
6. Fasten shock absorber (1) to rear fork (C) with stock washer (B) and bolt (A) previously removed.
  - a. Apply Loctite 243 (blue) 99642-97 to bolt threads.
  - b. Apply anti-seize compound to bolt shoulder.
  - c. Thread bolt through shock absorber eye and into rear fork mount, but do not tighten.
7. Repeat Steps 5 and 6 for other shock absorber.
8. See Additional Parts Required. Tighten each rear shock mounting bolt (A) to 121-136 ft-lbs (164.1-184.4 Nm).
9. Tighten each flanged nut (2) to 32-39 ft-lbs (43.4-52.9 Nm).

### SHOCK ABSORBER ADJUSTMENT

#### NOTE

*The initial shock-absorber spring-compression setting is set to the minimum preload position. Both shock absorbers are set equally from the manufacturer.*

*Adjust shock-absorber spring compression to accommodate the weight the motorcycle will usually carry.*

-J05536

Many Harley-Davidson<sup>®</sup> Parts & Accessories are made of plastics and metals which can be recycled. Please dispose of materials responsibly.

1 / 3

1. See Figure 1. Place a mark in the same position on the adjuster plate (6) of each shock absorber.
2. Loosen jam nut (7) on each shock absorber.

**▲ WARNING**

**Adjust both shock absorbers equally. Improper adjustment can adversely affect stability and handling, which could result in death or serious injury. (00036b)**

3. Use shock absorber adjustment spanner wrench (8) from kit to rotate each adjuster plate to loosen or tighten the shock-absorber springs.
  - a. Turn adjuster plates OUT (counterclockwise, toward jam nut), to increase spring preload for heavier loads.

- b. Turn adjuster plates IN (clockwise, away from jam nut), to decrease spring preload for lighter loads.

4. Adjust both shock absorbers equally, the same number of turns, and to the same position relative to the marks made in Step 1.

*NOTE*

*Make sure motorcycle is supported as lifting and securing devices are removed. Failure to properly support motorcycle may cause it to fall over.*

5. Tighten jam nut (7) against each of the shock-absorber adjuster plates (6).
6. Remove the screw jack from under the rear wheel.
7. Lower rear of motorcycle back down with crane or hoist, then free bike from lifting and securing devices.

## SERVICE PARTS

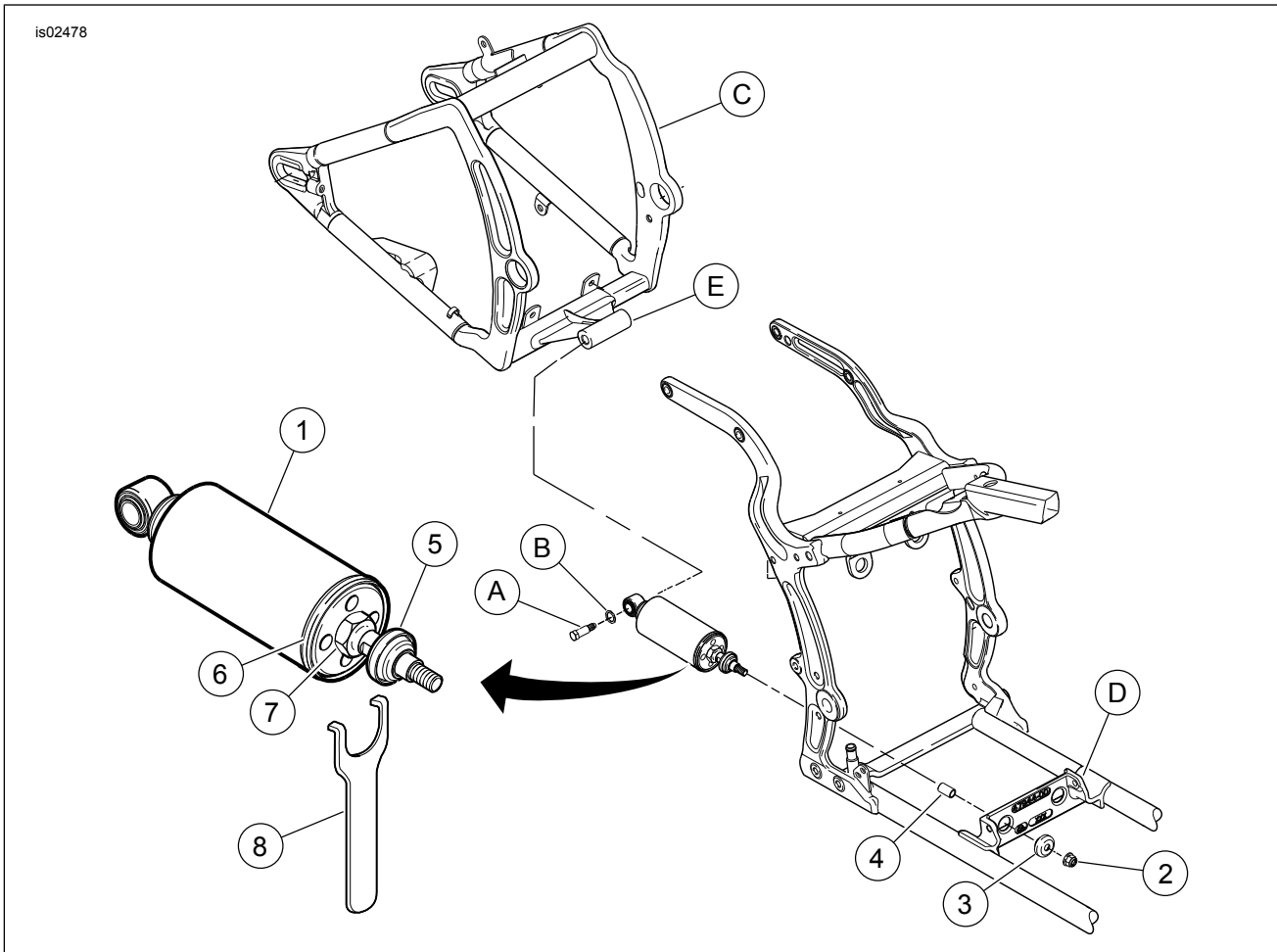

**Figure 1. Service Parts: Softail Rear Shock Absorber Kit**

**Table 1. Service Parts: Softail Rear Shock Absorber Kit**

Item	Description (Quantity)	Part Number
1	Shock absorber	54508-00B
2	Nut, flange with nylon insert	45764-00
3	Outer washer and grommet	56183-00
4	Bushing	56182-00A
5	Inner washer and grommet	56183-00
6	Adjuster plate	Not Sold Separately
7	Nut, jam	Not Sold Separately
8	Spanner wrench	94455-89

**Items mentioned in text, but not included in kit:**

**Table 1. Service Parts: Softail Rear Shock Absorber Kit**

<b>Item</b>	<b>Description (Quantity)</b>	<b>Part Number</b>
A	Stock bolt	
B	Stock washer	
C	Rear fork	
D	Frame crossmember	
E	Rear fork mount	