



INSTRUCTIONS

-J03347

REV. 2006-09-27

ONE-PIECE DETACHABLE SISSY BAR UPRIGHT AND PAD KITS

GENERAL

Kit Number

53618-05, 53928-05

Models

For model fitment information, please see the P&A Retail Catalog or the Parts and Accessories section of www.harley-davidson.com (English only).

Additional Parts Required

Separate purchase of additional parts or accessories may be required for proper installation of the Sissy Bar Upright Kit on your model motorcycle. Refer to the latest Harley-Davidson Genuine Motor Accessories and Genuine Motor Parts catalog for a list of required parts or accessories for your model.

Kit Contents

See Figure 3 and Table 1.

INSTALLATION

Passenger Upright Installation

1. See Figure 1. Stand behind the motorcycle, and place (10) the front upright notches (2) into the front docking points (3).
2. See Figure 2. Check for correct notch engagement.

NOTE

Failure to correctly engage the sideplate notches to the docking points may result in damage to the rear docking points.

3. See Figure 1. Pull (11) the rotary latches (4) back into their rearmost position. Align the latches over the rear docking points (7), making sure the latches and rear notches (6) fit into the neck (8) of the rear docking points.

NOTE

This may require some gentle squeezing or spreading of the upright sideplates.

4. Push downward (12) on the sideplates, and close the rotary latches by pressing (13) the latch lever as far forward as it will go. A click will be heard when the latch is in place. **If the latch does not close, do not force it.**

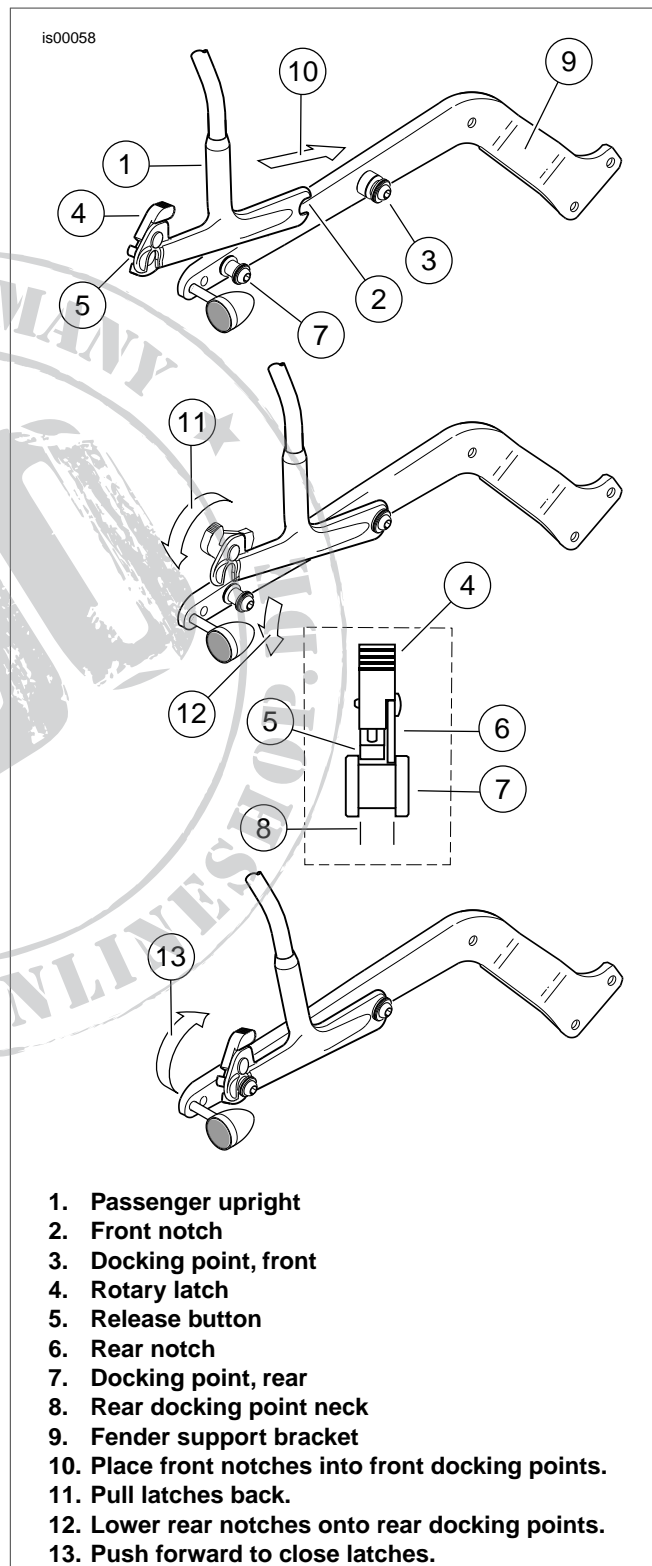
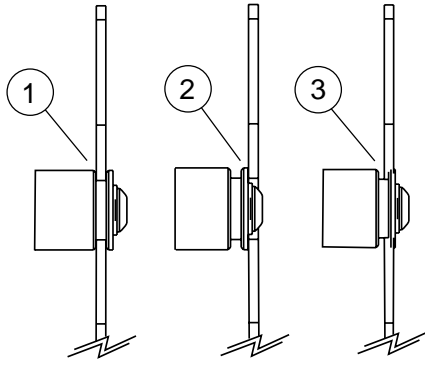

Figure 1. Detachable Passenger Upright

is00060



- 1. Correct
- 2. Incorrect
- 3. Incorrect

Figure 2. Upright Notch to Docking Point Engagement

5. See Figure 2. Re-check for correct notch engagement.

WARNING

After installing sissy bar/sideplate assembly, pull upward to be sure it is locked in position. While riding, a loose sissy bar/sideplate assembly can shift causing loss of control, which could result in death or serious injury. (00388a)

WARNING

Federal Motor Vehicle Safety Standard (FMVSS) 108 requires motorcycles to be equipped with rear and side reflectors. Be sure rear and side reflectors are properly mounted. Poor visibility of rider to other motorists can result in death or serious injury. (00336b)

6. If rear side reflectors for this model motorcycle were included in the Docking Hardware Kit or Saddlebag Kit, remove the original equipment reflectors and install the reflectors supplied with that kit.

Backrest Pad Installation

See Figure 3. Fasten the backrest pad (2) to the passenger upright (1) using the button-head screw (3) as shown.

REMOVAL

To remove the upright, press the release buttons and pull the rotary latches back. Carefully lift the rear of the sideplates up, and pull the upright out of the front docking points.

SERVICE PARTS

is00061

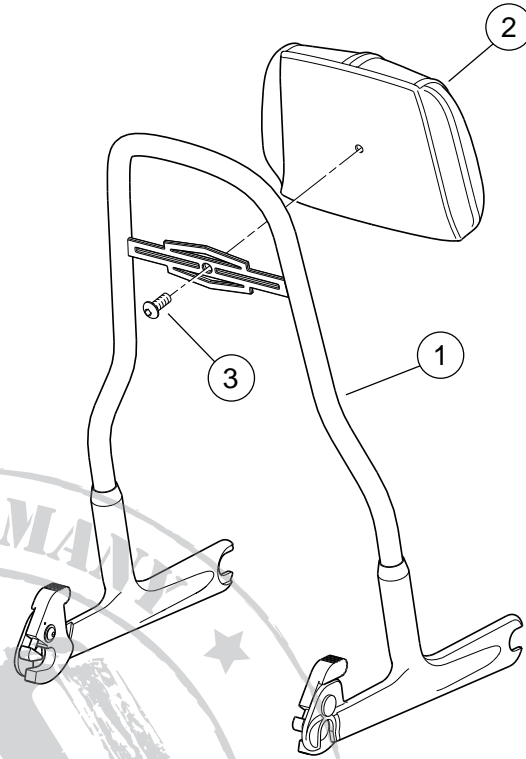

Figure 3. Service Parts: One-Piece Detachable Passenger Upright and Pad Kits (-J03347)

Table 1. Service Parts: One-Piece Detachable Passenger Upright and Pad Kits

Item	Description (Qty)	Part No.
53618-05: One-Piece Detachable Passenger Upright Kit		
1	Detachable sideplate and upright assembly	Not sold separately
53928-05: Backrest Pad Kit		
2	Backrest pad	Not sold separately
3	Cap screw, hex socket	94385-92T