



INSTRUCTIONS

-J03078

REV. 07-14-2003

Kit Number 53826-00B

CHROME SADDLEBAG COVER WINGTIP TRIM KIT

General

This kit fits 1993 and later Touring Models equipped with fiberglass or black plastic saddlebags.

IMPORTANT NOTE

To ensure proper fitting of the Wingtip Trim, you must know the material used to construct your saddlebag. Portions of the instructions for installation are different for each material.

Open the saddlebag cover and refer to Figure 1 to determine whether your saddlebag is fiberglass or black plastic, and follow the installation instructions for that material.

This kit is **not compatible** with saddlebag cover rails other than Chrome Saddlebag Cover Trim Rail Kit 53662-87T.

See the Service Parts illustration for kit contents.

NOTE

A Service Manual for your motorcycle is available from your Harley-Davidson Dealer.

Installation

NOTE

The following procedures can be performed with the saddlebags on or off of the motorcycle, and the covers on or off of the saddlebags. Figures show saddlebag covers removed.

1. Open the saddlebags and remove all loose contents.
2. Thoroughly clean the left and right saddlebag covers, and let them dry completely.
3. See Figure 2 for your saddlebag material. Position a straightedge against the check strap mounting posts of one of the covers, and mark or scribe a guide line along the straightedge as shown.

NOTE

When applying the templates in the following steps, make sure the templates are aligned as instructed, and the respective "LEFT SIDE" or "RIGHT SIDE" lettering is clearly readable when applied to the applicable (left or right side) cover. The templates are designed to be easily removed from the first cover and re-applied to the remaining cover.

When applying the templates, ensure that each template is correctly positioned **BEFORE** drilling the first hole.

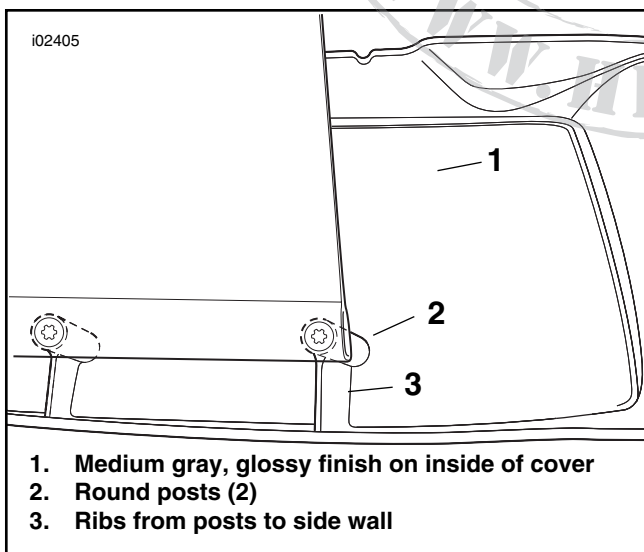

Fiberglass

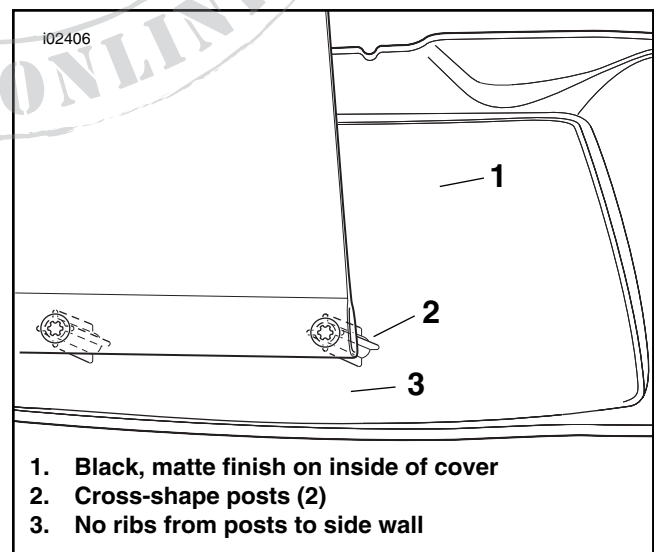

Black Plastic

Figure 1. Saddlebag Material Identification (Right Side Covers Shown)

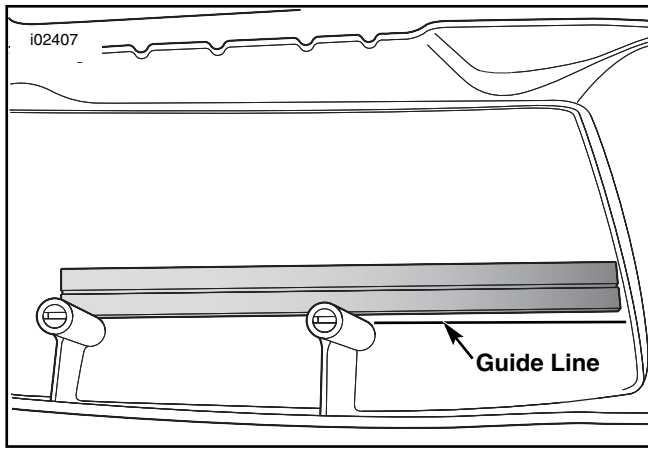

(Fiberglass Cover)

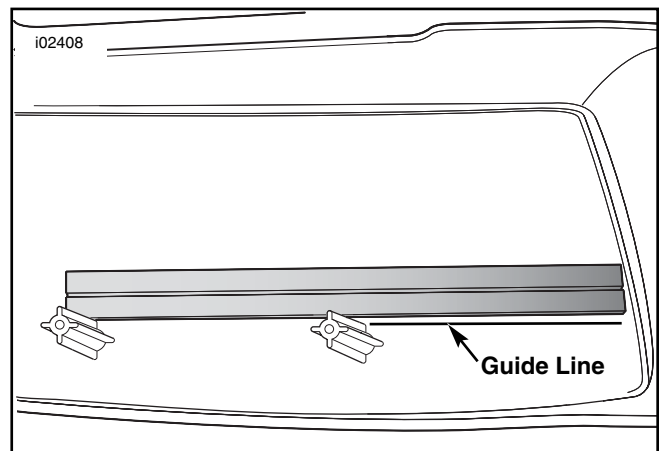

(Black Plastic Cover)

Figure 2. Position the Straightedge (Right Side Cover Shown)

- See Figure 3. Obtain the “INNER TEMPLATE” from the kit. Place the template inside the saddlebag cover with the correct “SIDE” text readable, and with the longer straight edge of the template (without the tab) closest to the check strap mounting posts.

For fiberglass covers: line up the inside edge of the template with the guide line made in Step 3.

Slide the template toward the front of the saddlebag cover, allowing it to curve upward until the leading edges of the two legs are flush with the top of the ridge that runs around the lip. Make sure the straight edge of the template is still positioned along the guide line.

Fit the entire template tightly to the inside of the cover, work any bulges out of the template, and tape it securely into place on the inside of the saddlebag cover.

For black plastic covers: align the line labelled “BLACK PLASTIC” on the template with the guide line made in Step 3.

Slide the template toward the front of the saddlebag cover, allowing it to curve upward until the line labelled “BEND LINE” and the line on the wide tab fit tightly into the inside leading corner of the cover.

Align the tips of the outline arrows printed on the two tabs.

Line up the outside edge of the template and the large radius opposite the guide line with the tool mark molded into the inside of the cover.

Make sure the “BLACK PLASTIC” line is still positioned along the guide line. Fit the entire template tightly to the inside of the cover, work any bulges out of the template, and tape it securely into place on the inside of the saddlebag cover.

For ALL covers: Double-check that the template is aligned correctly.

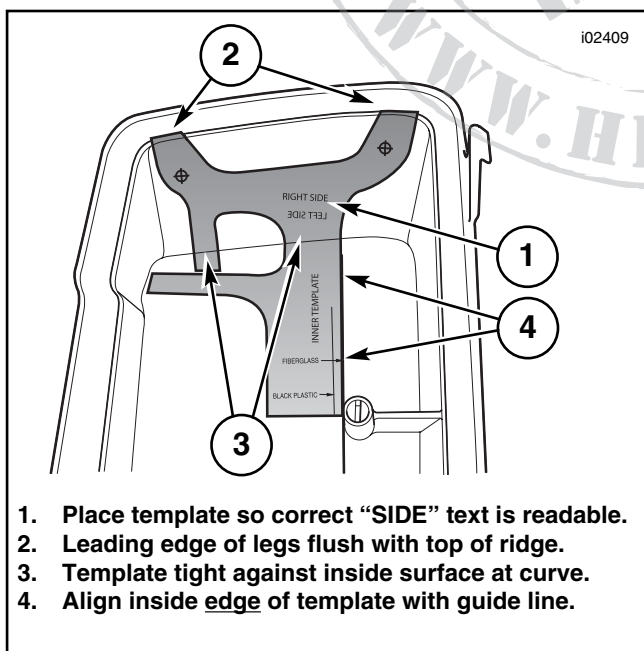

(Fiberglass Cover)

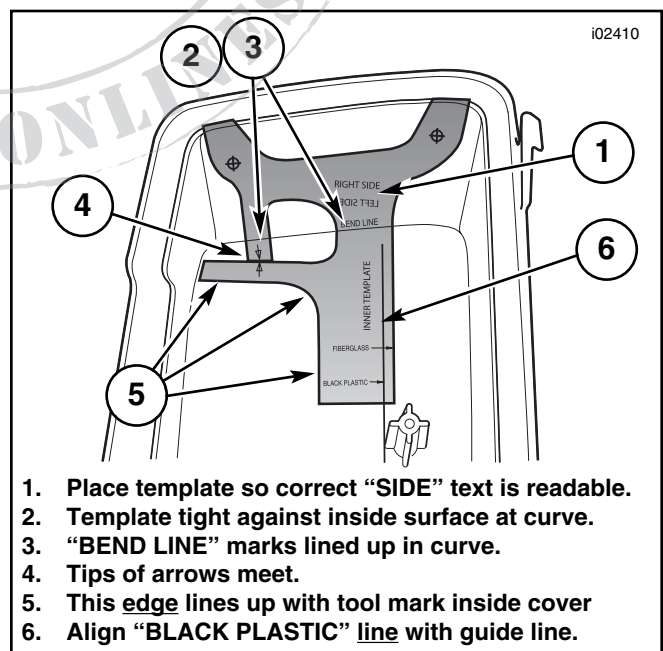

(Black Plastic Cover)

Figure 3. Position the Inner Template (Right Side Cover Shown)

- Use a centerpunch to mark the centers of the two template holes on the inside of the cover, then drill a 1/8 inch (3 mm) pilot hole at each center punch mark.
- Turn the saddlebag cover right-side up.

NOTE

It may be helpful to place a 1/8 in. diameter object, like a drill bit or piece of weld rod, in the pilot holes to assist in lining up the outer template.

- Obtain the "OUTER TEMPLATE" from the kit. Place the template on the front of the saddlebag cover with the correct "SIDE" text readable, and with the two inboard holes lined up with the pilot holes drilled in Step 5.

See Figure 4. Wrap the two ends of the template around the front corners of the saddlebag cover, keeping the bottom of the template an equal distance from the lip from end to end. Work any bulges out of the template, and tape it securely into place on the outside of the saddlebag cover.

Double-check that the template is aligned correctly.

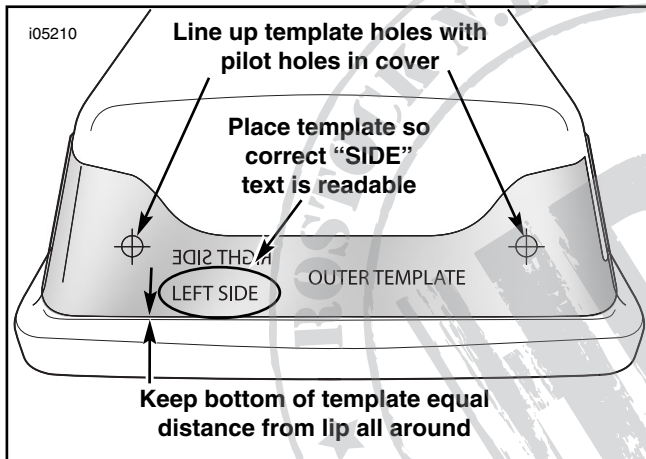

Figure 4. Position the Outer Template

- Use a centerpunch to mark the centers of the two template holes on the sides of the cover, then drill a 1/8 inch (3 mm) pilot hole at each center punch mark.
- Peel and discard the tape from both templates. Remove the templates from the cover and set aside.
- Enlarge each of the holes using a 3/8 inch (9 mm) drill bit. Use a small rat-tail file or similar tool to smooth out any jagged or rough edges. Clean the inside and outside of the saddlebag lid with a soft cloth, making sure to remove any shavings left from drilling.
- Wingtip assemblies are side-specific. Obtain the correct wingtip and remove the rubber protectors from each of the threaded studs.

NOTE

Before installing the wingtip assembly, test fit the part to ensure there is adequate clearance for all four studs through the drilled holes in the saddlebag cover.

Proper position of the wingtip assembly is for the bottom edge to fit squarely into the curve of the lip.

If the studs do not fit loosely in the holes, it may be necessary to slightly enlarge the holes to provide clearance and maintain proper alignment of the wingtip assembly on the saddlebag cover.

- See Figure 5. Align and position the wingtip into the drilled holes, being careful not to scratch the saddlebag cover finish.



Figure 5. Wingtip In Position (Right Side Shown)

- See the Service Parts illustration. Obtain the nylon washers and brass thumb nuts from the kit. Press the front of the wingtip against the saddlebag cover. Install a nylon washer onto a brass thumb nut, and thread the nut onto one of the inboard studs Repeat for the second inboard stud. Finger-tighten both nuts at this time.
- Install a nylon washer onto a brass thumb nut, and thread the nut onto one of the side studs Repeat for the second side stud. Finger-tighten both nuts.
- Tighten the two inboard nuts securely, then tighten the two side nuts.

NOTE

The side nuts may chip away the edges of the holes while being tightened. This is acceptable.

- Repeat for the other saddlebag cover.



Service Parts

Part No. 53826-00B

Date 07/03

Saddlebag Wingtip Cover Kit

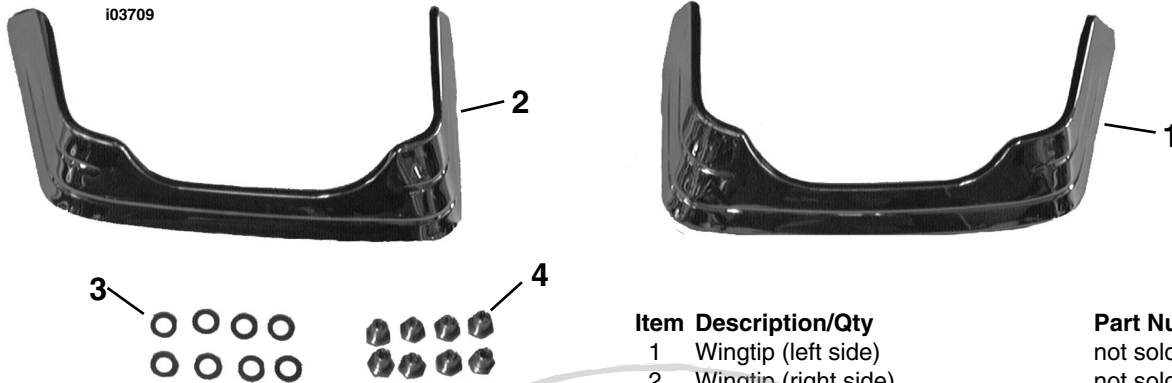

Item	Description/Qty	Part Number
1	Wingtip (left side)	not sold separately
2	Wingtip (right side)	not sold separately
3	Washer, nylon (8)	not sold separately
4	Thumb nut, brass (8)	not sold separately
5	Template, inner (not shown)	not sold separately
6	Template, outer (not shown)	not sold separately

