



INSTRUCTIONS

-J00958

REV. 11-2-98

Kit Number 53528-95B

SPORTSTER DOCKING HARDWARE WITHOUT SADDLEBAG SUPPORTS

General

This kit is designed to fit 1994 and later Sportsters without saddlebags.

See Service Parts on page two for kit contents.

Installation

NOTE

Perform the following procedures on one side of the motorcycle at a time until instructed to go to the other side.

*NOTE

See Figure 1. 1998 and later models, and models with kit number 59722-98 installed have a support weldment and do not have a locknut or "T" spacer behind the last hole of the fender support. The screw threads directly into the weldment.

1. See Figure 1. Remove the original bolts and locknut(s)* from the two fender support bracket docking point locations. Leave the grommets (1) and "T" spacer(s)* (2) in place.
2. See Service Parts Illustration. Attach the docking points (2 & 3) as shown with the locknut(s)* (4) on the inside of the fender. Coat bolt (1) threads with Loctite 242 (Blue) before installation. Tighten the locknut(s)* (4) to 15 ft-lbs (20 Nm).

Reflector Removal and Reattachment

⚠WARNING

Federal Motor Vehicle Safety Standard (FMVSS) 108 requires all motorcycles to be equipped with side reflectors. The rear fender factory installed reflectors will have to be relocated to install detachable luggage racks. This loss of visibility to other motorists could result in an accident and possible personal injury.

⚠CAUTION

Use care when removing the reflector from the motorcycle to avoid damaging painted or chromed surfaces, or damaging the reflector, which must be reused.

3. Carefully remove the rear reflector. Remove any remaining adhesive from the back side of the reflector and any adhesive from the side of the fender.
4. Trim the double-sided adhesive tape to match the shape of the reflector. Attach the tape to the rear side of the reflector.
5. See Figure 2. Reattach the reflector to the fender by aligning the lower front corner of the reflector with the centerline of the front docking point. The reflector should be 3/4 of an inch above and parallel to the fender support bracket cover.

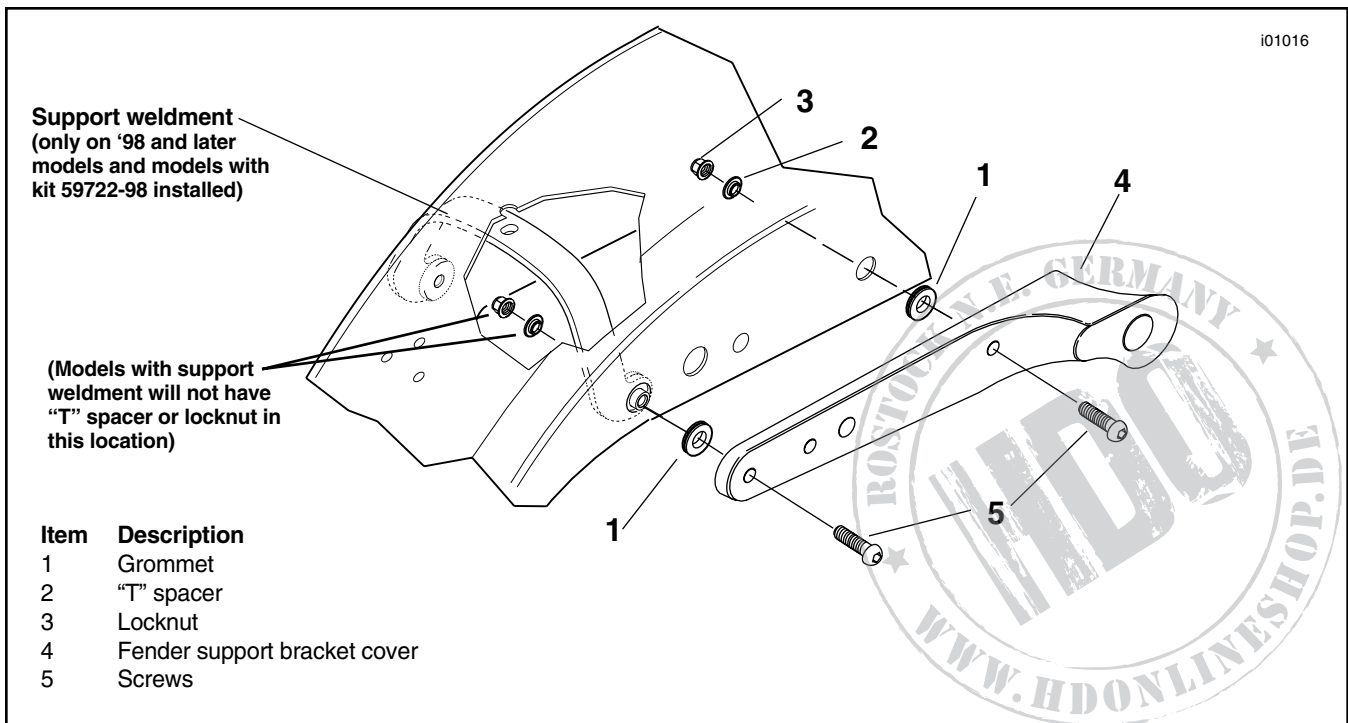

Figure 1. Rear Fender Support (right side shown)

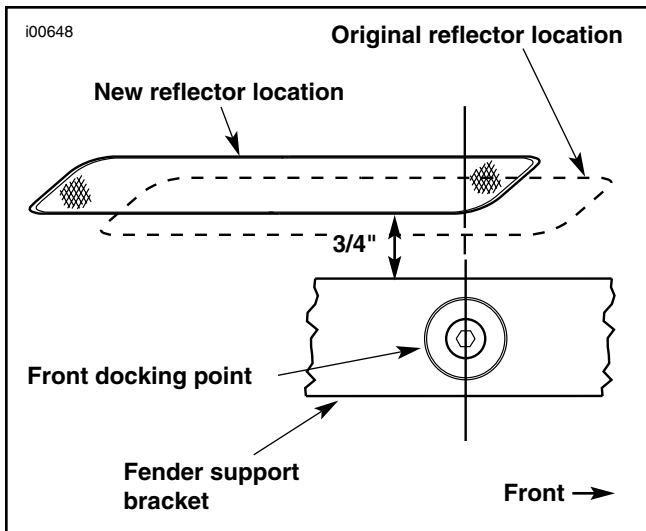

Figure 2. Reflector Relocation

6. Repeat steps 1–5 on other side of the motorcycle.

NOTE

In time docking points may wear, causing the mating luggage rack or sideplates to become loose. The fit may be tightened using the following procedure.

1. Loosen docking hardware
2. Rotate docking points clockwise approximately 45°.
3. Tighten docking hardware to the appropriate torque values.

Repeat as often as required, up to 3 times.



Service Parts

Part No. 53528-95B

Date 11/98

Sportster Docking Hardware Without Saddlebag Supports

sp53528-95B

Support weldment
(on 1998 and later
models, and models
with kit 59722-98
installed)

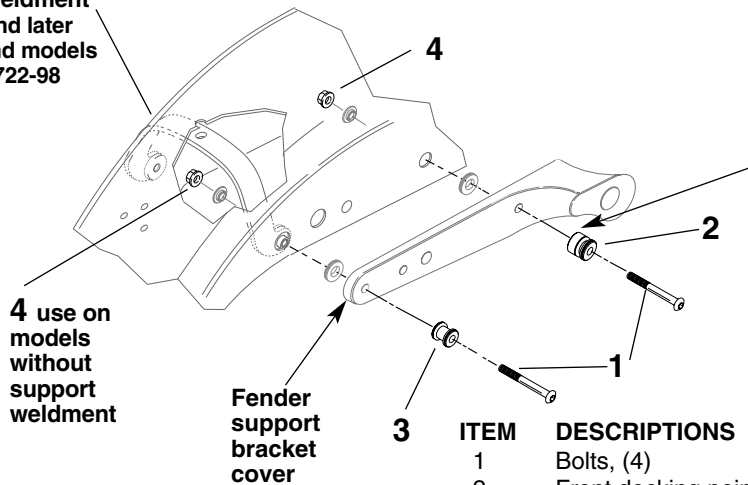

The countersunk end of each docking point hole faces the fender support bracket

4 use on models without support weldment

Fender support bracket cover

ITEM	DESCRIPTIONS	PART NO.
1	Bolts, (4)	4158
2	Front docking point (2)	53685-96
3	Rear docking point (2)	53686-96A
4	Locknuts, (4)	7531
	Double-sided adhesive tape (not shown)	

