



INSTRUCTIONS

-J02516

REV. 05-02-2002

Kit Number 53388-03

RIGID MOUNT SIDEPLATE HARDWARE KIT

General

This kit is required for installation of Rigid Mount Sideplate Kits:

- **53374-03** for 2000 through 2002 FLSTC and FLSTS Models when not equipped with the Softail Wide Tire Kit.
- **53378-03 or 53387-03** for 2000 through 2002 FXST, FXSTB, FXSTS and FLSTF Models when not equipped with the Softail Wide Tire Kit.

NOTE

Models equipped with a Softail Wide Tire Kit **DO NOT** need this Kit. Models equipped with a Softail Wide Tire Kit will utilize the appropriate hardware supplied in that kit.

NOTE

These kits are designed to be used **ONLY** with Genuine Harley-Davidson Sissy Bar Uprights.

See the Service Parts illustration on the last page of these instructions for kit contents.

CAUTION

When performing this installation, be careful not to scratch nearby painted or chrome surfaces.

Installation (2000-2002 FXST/B/S & FLSTF)

1. See the Service Parts illustration. Remove and discard the four bolts (3a and 3b), washers (2) and nuts (1) that secure the fender to the fender brace on each side of the motorcycle.
2. Attach a sissy bar (not included in the kits) to both sideplates from the Rigid Mount Sideplate Kit using the four chrome 1/4"-20 Torx capscrews supplied with that kit. **Do not tighten the capscrews now.**
3. With the sissy bar attached to the sideplates, position the sideplates on the outside of the fender braces.

WARNING

Button head screws from wide tire kit must be installed from the inside out, with the button heads on the inside of the fender. Failure to do so could result in bolt contacting tire, which could result in death or serious injury.

4. **Models equipped WITH the Wide Tire Kit** MUST use the hardware and instructions found in that kit. Follow the instructions supplied with the Wide Tire Kit to re-orient the fasteners to come from the inside of the fender out. Hardware from the Sideplate Hardware Kit will not be used.

Models WITHOUT the Wide Tire Kit:

Install four chrome 3/8"-16 screws (3a and 3b) from this kit through the holes in the side plate, fender brace and fender. Reach inside the fender and install the washers (2) and nuts (1) from the kit onto the screws. Tighten the nuts to 19 ft-lbs (26 Nm).

i03600a.eps

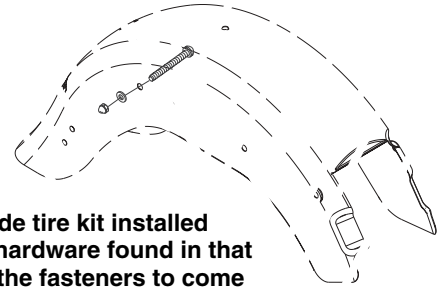

Models with wide tire kit installed MUST use the hardware found in that kit to re-orient the fasteners to come from the inside of the fender out.

Figure 1. Hardware from wide tire kit (FLSTC fender shown)

5. Remove the four 1/4"-20 Torx capscrews attaching the sissy bar to the sideplates. Apply Loctite® 262 (red) to the threads of the screws and reinstall them into the sideplate holes. Tighten to 8-10 ft-lbs (11-14 Nm).

Installation (2000 through 2002 FLSTC/S)

NOTE

To keep the fender aligned, completely install the sideplate on one side of the motorcycle before proceeding to the second side. The sissy bar should be installed last.

1. For models equipped with saddlebags:

- a. Remove the saddlebag, and retain the mounting hardware for later reinstallation.
- b. See the Service Parts illustration. Remove and discard the bolts (3a), washers (2) and nuts (1) that secure the rear fender to the fender brace. Remove and retain the two saddlebag mounting studs for later use. The nuts and washers can be discarded.

For models NOT equipped with saddlebags:

- a. Remove and discard the rearmost bolt (3a), washer (2) and nut (1) that secure the rear fender to the fender brace.
 - b. Remove and discard the two bolts (3b), washers (2) and nuts (1) that secure the fender and brace to the frame.
2. See the Service Parts illustration. Position the correct sideplate from the Rigid Mount Sideplate Kit to the outside of the fender brace.

WARNING

Button head screws from wide tire kit must be installed from the inside out, with the button heads on the inside of the fender. Failure to do so could result in bolt contacting tire, which could result in death or serious injury.

3. Models equipped WITH the Wide Tire Kit MUST use the hardware and instructions found in that kit. Follow the instructions supplied with the Wide Tire Kit to re-orient the fasteners to come from the inside of the fender out. Hardware from the Sideplate Hardware Kit will not be used.

Models WITHOUT the Wide Tire Kit:

With saddlebags: Reinstall the saddlebag mounting studs through the sideplate, fender brace, frame and fender. Reach inside the fender and install two washers (2) and nuts (1) from the kit onto the studs.

Install one chrome 3/8"-16 screw (3a) from the kit and a stock washer through the rear hole in the sideplate, fender brace and fender. Reach inside the fender and install a washer (2) and nut (1) from the kit onto the screw.

Without saddlebags: Install three chrome 3/8"-16 screws (3a and 3b) from the kit and stock washers through the holes in the side plate, fender brace and fender. Reach inside the fender and install the washers (2) and nuts (1) from the kit onto the screws.

4. Repeat steps 1-3 for the opposite side.
5. Install a sissy bar (not included in the kits) into the sideplates. Apply Loctite® 262 (red) to the threads of the chrome 1/4"-20 capscrews from the Sideplate Kit and insert them into the sideplate holes. Tighten to 8-10 ft-lbs (11-14 Nm).
6. Tighten the nuts securing the sideplates to the fender supports to 19 ft-lbs (26 Nm).
7. Reinstall the saddlebags.



Service Parts

Part No. 53388-03

Date 05/02

Rigid Mount Sideplate Hardware Kit

i04756.eps

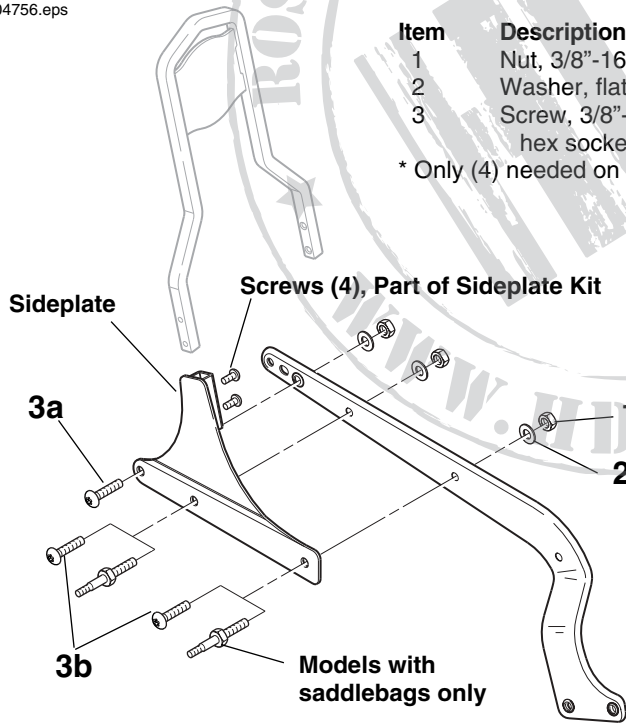

FLSTC and FLSTS

Item	Description	Qty.	Part No.
1	Nut, 3/8"-16 hex lock, with nylon insert	6*	7667
2	Washer, flat, 3/8"	6*	6701
3	Screw, 3/8"-16 x 1-1/4", button head, hex socket (chrome)	6*	4098

* Only (4) needed on FXST, FXSTB, FXSTS and FLSTF models.

i03600a.eps

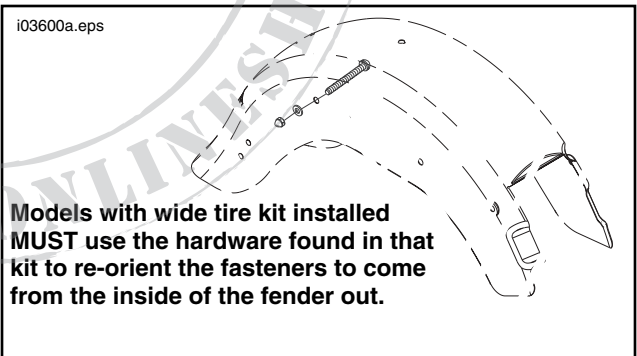

i04756.eps

