



INSTRUCTIONS

-J01935

REV. 2007-05-07

SOFTAIL SADDLEBAG KIT

GENERAL

Kit Number

53061-00B

Models

For model fitment information, please see the P&A Retail Catalog or the Parts and Accessories section of www.harley-davidson.com (English only).

Additional Parts Required

For 1984-1999 FLSTF and FXST models: Separate purchase of Directional Relocation Kit 53692-96 is required.

Installation of this kit with the following seats requires the use of Spacer Kit 90976-01A, which is available from a Harley-Davidson dealer.

- Diamondback seats
- Seats with rider backrests
- Stock Fat Boy seat
- Stock FLSTC seat
- Stock FXSTC seat
- Stock FXSTC sissy bar (2007-later only)
- Sundowner and double bucket seats
- Any other seats that contact lid of saddlebag

LOCTITE® 243 Threadlocker and Sealant - Blue (Part Number 99642-97) is available from a Harley-Davidson dealer.

NOTE

Spacer Kit 90976-01A is not required if installing the kit with Harley-Davidson detachable sissy bar sideplates.

For 2000-2002 Softail models equipped with Wide Tire Kit: Use the hardware supplied in that kit.

- FX models use Wide Tire Kit 43685-00A
- FL models use Wide Tire Kit 44490-00A

WARNING

The rider's safety depends upon the correct installation of this kit. Use the appropriate service manual procedures. If the procedure is not within your capabilities or you do not have the correct tools, have a Harley-Davidson dealer perform the installation. Improper installation of this kit could result in death or serious injury. (00333a)

NOTE

This instruction sheet references Service Manual information. A Service Manual for your model motorcycle is required for this installation and is available from a Harley-Davidson Dealer.

Kit Contents

See Figure 5, Table 3 and Figure 6, Table 4.

WARNING

Do not exceed saddlebag weight capacity. Put equal weight in each bag. Too much weight in saddlebags can cause loss of control, which could result in death or serious injury. (00383a)

NOTE

Maximum saddlebag weight capacity is 7 pounds (3.18 Kg) for each bag.

WARNING

Federal Motor Vehicle Safety Standard (FMVSS) 108 requires motorcycles to be equipped with rear and side reflectors. Be sure rear and side reflectors are properly mounted. Poor visibility of rider to other motorists can result in death or serious injury. (00336b)

NOTE

Proper installation of this kit requires that tasks be completed for one side of the motorcycle first before continuing to the opposite side.

INSTALLATION

NOTE

For 2007-2008 FXSTSSE Models: The decorative fender rail strip must first be removed.

Table 1. Wide Tire Kit Screws (3/8-16)

Part Number and Length	Wide Tire Kit 44490-00A, Hardware Kit 43761-00	Wide Tire Kit 43685-00A, Hardware Kit 43763-00
4030 2-1/2 in.	X	X
4225 3-1/2 in.	X	X
4224 1-1/2 in.	X	X
4044 1-1/4 in.	X	X
4215 2 in.	X	
3912 2-3/4 in.		X
4228 2-1/4 in.	X	X
4229 3-1/4 in.	X	X

- See Figure 2. Install saddlebag using screw (from wide tire kit) (1), washer (2) and nut (3). The screws are installed from inside to outside of fender.

NOTE

If you do not have the appropriate screw from the Wide Tire Kit, it can be purchased from a Harley-Davidson dealer.

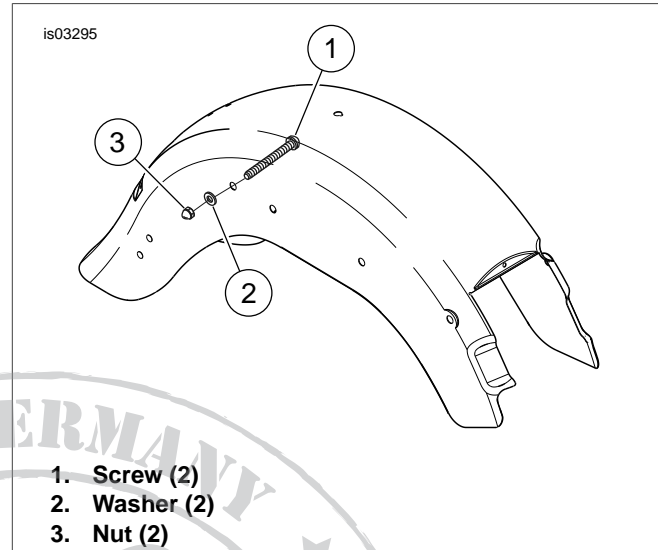

Figure 2. Install Hardware (FLST)

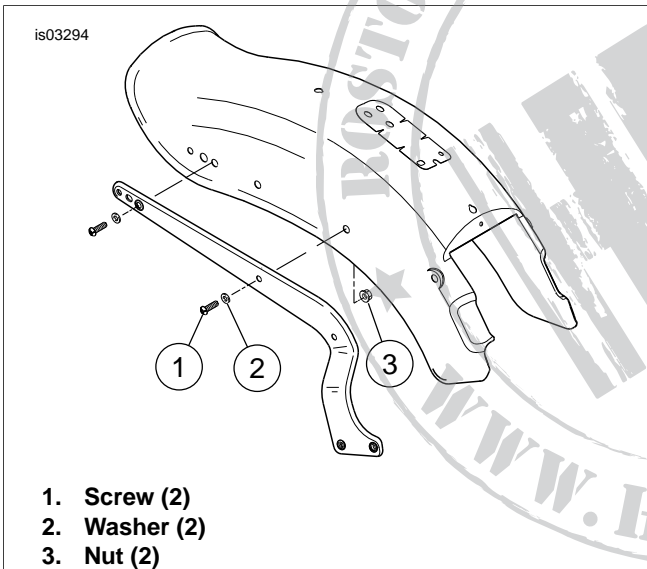

Figure 1. Remove Hardware (FXST)

2000-2002 Models with Wide Tire Kit

- See Figure 1. Remove and discard stock screws (1) and washers (2) from fender support.

WARNING

Button head screws from wide tire kit must be installed with button heads on inside of fender. Fastener contact with tire can lead to premature tire failure, which could result in death or serious injury. (00417b)

- See Table 1. Determine appropriate screw from Wide Tire Kit.

CAUTION

Failure to tighten saddlebag mounting bolts to specified torque could result in damage to saddlebags. (00406c)

- Tighten all saddlebag hardware to 22 ft-lbs (30 Nm).
- Install reflectors on saddlebag. Refer to "Install Reflectors" subtopic.

2000-2002 Models without Wide Tire Kit

NOTE

Refer to Table 2 to determine appropriate front and rear screws to install.

- See Figure 1. Remove and discard stock screws (1) and washers (2) from fender support.
- See Figure 5. Attach front of saddlebag (1) to fender as follows:
 - Without Spacer Kit:* Use screw (2), washer (3) and nut (4). Hand-tighten to keep in place.
 - With Spacer Kit:* Use screw (2), washer (3), nut (4) and spacer (5). Hand-tighten to keep in place.
- Attach rear of saddlebag (1) to fender as follows:

FLST models:

- Without Spacer Kit:* Use screw (6), washer (3) and acorn nut (7). Hand-tighten to keep in place.
- With Spacer Kit:* Use screw (6), washer (3), acorn nut (7) and spacer (5). Hand-tighten to keep in place.

FXST models:

- a. *Without Spacer Kit:* Use screw (6) and washer (8). The screw threads into the insert in the license plate bracket (A). Hand-tighten to keep in place.
- b. *With Spacer Kit:* Use screw (6), washer (8) and spacer (5). Hand-tighten to keep in place.

NOTE

If the saddlebag hanger contacts the rear turn signal, it will be necessary to loosen the turn signal and adjust to allow clearance with the saddlebag hanger as follows:

- Loosen the turn signal mount screw 2-3 turns.
- Adjust rearward to allow approximately 1/32 in. of clearance between the turn signal and the saddlebag hanger.
- Tighten the turn signal mount screws.

CAUTION

Failure to tighten saddlebag mounting bolts to specified torque could result in damage to saddlebags. (00406c)

- 4. Tighten all saddlebag hardware to 22 ft-lbs (30 Nm).

NOTE

Check that front screws have at least one thread exposed beyond the nut after proper torque has been applied.

- 5. See Figure 5. Slip thread protector (9) over end of front screw (2).
- 6. Install reflectors on saddlebag. Refer to "Install Reflectors" subtopic.

2003 and Later Softails without Rigid Mount Sissy Bar

NOTES

Refer to Table 2 to determine appropriate front and rear screws to install.

Installation of 2007 and later FXSTC models require the use of Spacer Kit 90976-01A.

- 1. See Figure 3 and Figure 4. Remove and discard stock screws (1) from fender support (2).

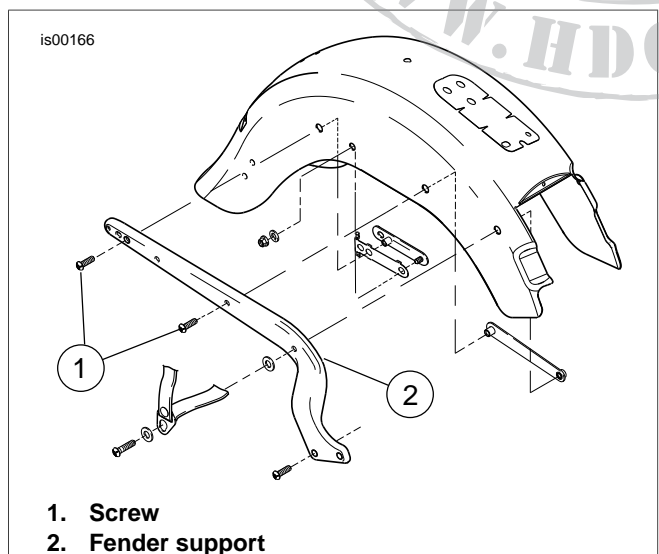

Figure 3. Fender Support Hardware (2006 FLSTF Shown)

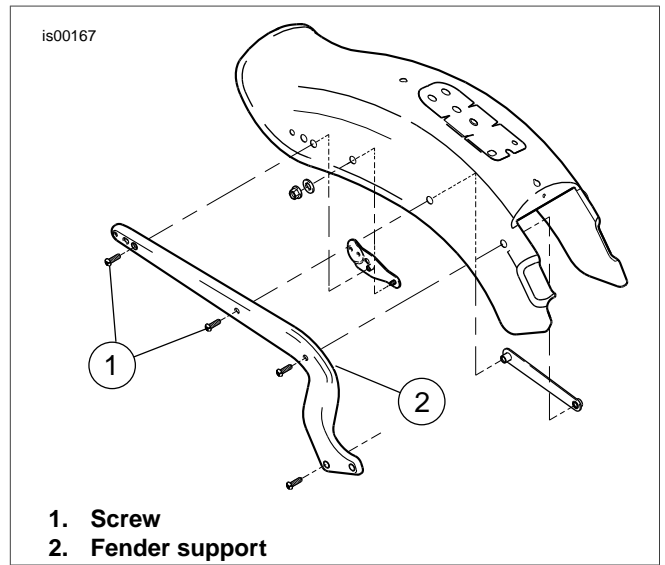

Figure 4. Fender Support Hardware (2006 FXST/S/B Shown)

- 2. *Without Spacer Kit:* See Figure 6. Install front and rear of saddlebag with screw (2, 4) and washer (3). Hand-tighten to keep in place.

With Spacer Kit: Install front and rear of saddlebag with screw (2, 4), washer (3), and spacer (5). Hand-tighten to keep in place.

CAUTION

Failure to tighten saddlebag mounting bolts to specified torque could result in damage to saddlebags. (00406c)

- 3. Tighten all saddlebag hardware to 22 ft-lbs (30 Nm).
- 4. Install reflectors on saddlebag. Refer to "Install Reflectors" subtopic.

2003 and Later Softails with Rigid Mount Sissy Bar

NOTE

Refer to Table 2 to determine appropriate front and rear screws to install.

- 1. See Figure 3 and Figure 4. Remove and discard stock screws (1) from fender support (2).

- 2. *Without Spacer Kit:* See Figure 6. Install front and rear of saddlebag with screw (2, 4) and washer (3). Hand-tighten to keep in place.

With Spacer Kit: Install front and rear of saddlebag with screw (2, 4), washer (3) and spacer (5). Hand-tighten to keep in place.

CAUTION

Failure to tighten saddlebag mounting bolts to specified torque could result in damage to saddlebags. (00406c)

- 3. Tighten all saddlebag hardware to 22 ft-lbs (30 Nm).

Table 2. Front and Rear Fender Support Screws

Accessory Combination	Model Fitment	Front Screws and Washers (Part Number/Size)					Rear Screws and Washers (Part Number/Size)				
		Number of washers to use	Not sold separately 3-3/4 in.	3528 3-1/4 in.	4420 2-3/4 in.	9469 2-1/4 in.	Number of washers to use	9470 2-1/2 in.	9469 2-1/4 in.	3528 3-1/4 in.	Not sold separately 3-1/2 in.
No Sissy Bar Sideplates and no Spacer Kit	2000-2002 Models	2			X		1		X		
	2003 - later Models	1				X	1		X		
No Sissy Bar Sideplates with Spacer Kit P/N 90976-01A	2000-2002 Models	2	X				1			X	
	2003 - later Models	1		X			1			X	
Rigid Mount Sissy Bar Sideplates and no Spacer Kit	2000-2002 Models	2			X		1	X			
	2003 - later Models	1				X	2	X			
Rigid Mount Sissy Bar Sideplates with Spacer Kit P/N 90976-01A	2000-2002 Models	2	X				1				X
	2003 - later Models	1		X			2			X	
Detachable Sissy Bar Sideplates	2000-2002 Models	2	X				1			X	
	2003 - later Models	1		X			1			X	

NOTE

Check that the screws are approximately flush with the inside surface of the fender bracket nut after proper torque has been applied.

Screws should not extend beyond the fender bracket by more than 0.12 in. (3.1 mm) to ensure adequate tire clearance. Screws should also not be shorter than 0.12 in. (3.1 mm) below the inside surface of the nut. Recheck screw length and number of washers if either of these cases is observed.

4. Install reflectors on saddlebag. Refer to "Install Reflectors" subtopic.

Install Reflectors (All Softail Models)

WARNING

Federal Motor Vehicle Safety Standard (FMVSS) 108 requires motorcycles to be equipped with rear and side reflectors. Be sure rear and side reflectors are properly mounted. Poor visibility of rider to other motorists can result in death or serious injury. (00336b)

1. See Figure 5 and Figure 6. Position reflector mount on lower right corner of saddlebag.
2. Mark holes on saddlebag with pen (or other appropriate tool).
3. Using soapy water, clean the surface where reflector will be installed.
4. Allow the surface to dry completely before continuing.

5. Using appropriate tool, make two 3/16 in. holes in saddlebag.
6. Install reflector mount on saddlebag using two push nuts.
7. Remove adhesive backing from reflector and install on mount.
8. Let the adhesive cure for at least 24 hours at no less than 60°F (16°C).

Install Opposite Saddlebag

After completing the installation for one side of the motorcycle, repeat the same tasks to install the saddlebag and reflector on the opposite side.

Fender Support Screws

See Table 2 to determine the front and rear fender support screws and washers for different accessory combinations.

MAINTENANCE

Docking Point Screws

CAUTION

Failure to tighten saddlebag mounting bolts to specified torque could result in damage to saddlebags. (00406c)

After 500 miles of on road use with the saddlebags installed, it is necessary to check the torque on the saddlebag mounting screws. Check to make sure the torque is still 22 ft-lbs (30 Nm). Tighten screws if necessary.

Saddlebag Docking Points

NOTE

In time, the docking points may wear, causing the lower front support brackets to become loose. The fit may be tightened using the following procedure:

1. Loosen docking point hardware.
2. Rotate docking points clockwise approximately 45 degrees.
3. Tighten docking point hardware to 22 ft-lbs (30 Nm).

This procedure can be repeated up to three times before replacement of the docking points is recommended.

Saddlebag Care

- For saddlebags with lid snaps, it will be necessary to oil the snaps periodically. Smear a drop of motor oil into the female side of the snap, being careful not to get any of the oil on the leather. Oil the snaps every two to three weeks.
- Apply the Genuine Leather Dressing (98261-91V) included with the saddlebag according to the instructions in the leather care kit.

SERVICE PARTS

is03301

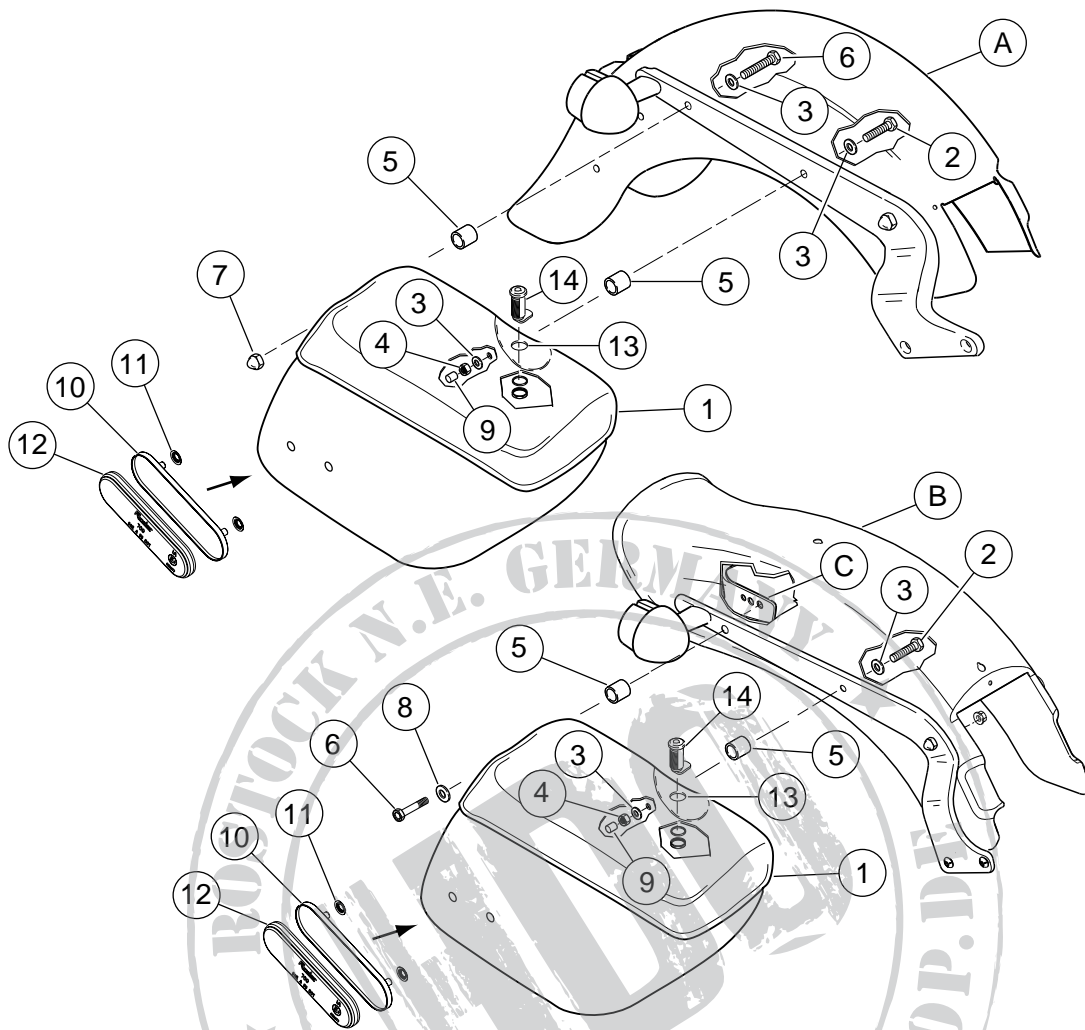

Figure 5. Service Parts: Softail Saddlebag Kit (Installation Shown on 2000-2002 FLST, FXST)

Table 3. Service Parts: Softail Saddlebag Kit (2000-2002 FLST, FXST)

Item	Description (Quantity)	Part Number	Item	Description (Quantity)	Part Number
1	Saddlebag, right	51555-00A	11	Push nut, reflector (4)	8126A
	Saddlebag, left (Not Shown)	51556-00A	12	Reflector (2)	59173-00
2	Screw, front (2)	See Table 2	13	Bezel assembly, R.H./L.H.	51554-00
3	Washer, 3/8 in. (6)	6400HB	14	Lock assembly (includes 2 locks, 2 keys)	51557-00A
4	Locknut, 3/8-16 (2)	7778	Service Kits:		
5	Spacer	See Service Kits	15	Spacer Kit (includes Items 2, 4, 5)	90976-01A
6	Screw, rear (2)	See Table 2	16	Reflector Kit (includes Items 10, 11, 12)	59480-04
7	Acorn nut (2)	7862	Items mentioned in text, but not included in kit:		
8	Lockwasher, 3/8 in. (2)	7038	A	FLST rear fender	
9	Thread protector (2)	Not Sold Separately	B	FXST rear fender	
10	Mount, reflector (2)	See Service Kits	C	License plate bracket assembly	

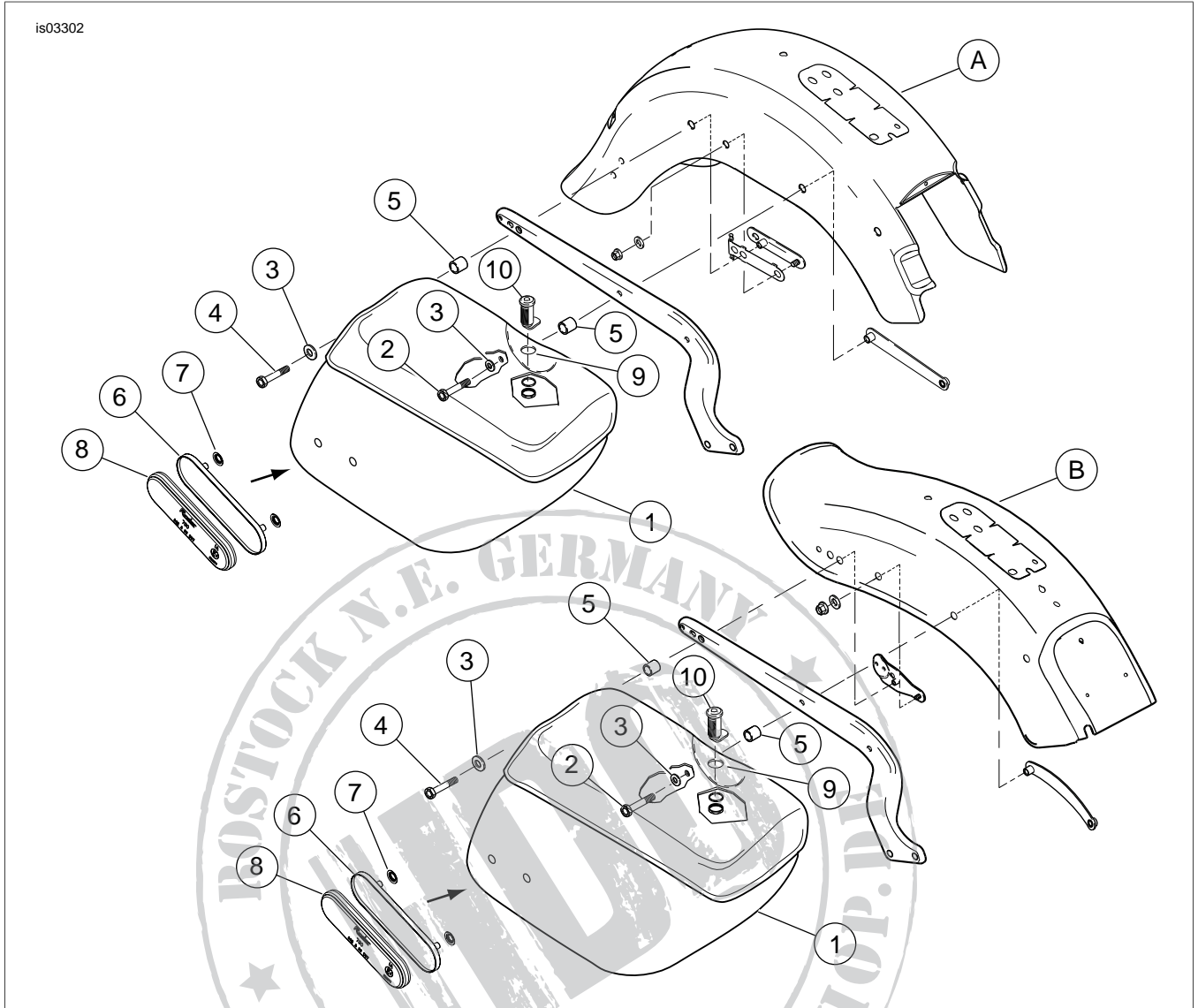

Figure 6. Service Parts: Softail Saddlebag Kit (Installation Shown on 2003-Later FLST, FXST)

Table 4. Service Parts: Softail Saddlebag Kit (2003-Later FLST, FXST)

Item	Description (Quantity)	Part Number	Item	Description (Quantity)	Part Number
1	Saddlebag, right	51555-00A	9	Bezel assembly (R.H./L.H.)	51554-00
	Saddlebag, left (Not Shown)	51556-00A	10	Lock assembly (includes 2 locks and 2 keys)	51557-00A
2	Screw, front (2)	See Table 2 for quantity	Service Kits:		
3	Washer, 3/8 in. (6)	See Table 2 for quantity	11	Spacer Kit (includes Items 2, 4, 5)	90976-01A
4	Screw, rear (2)	See Table 2 for quantity	12	Reflector Kit (2) (includes Items 6, 7, 8)	59480-04
5	Spacer (4)	See Service Kits	Items mentioned in text, but not included in kit:		
6	Mount, reflector (2)	See Service Kits	A	FLST rear fender	
7	Push nut, reflector (4)	8126A	B	FXST rear fender	
8	Reflector (2)	59173-00			