



INSTRUCTIONS

-J05564

2012-06-15

PREMIUM TOUR-PAK LATCH KITS

GENERAL

Kit Numbers

53000252, 53000253

Models

For model fitment information, see the P&A retail catalog or the Parts and Accessories section of www.harley-davidson.com (English only).

Installation Requirements

Loctite® 243 Medium Strength Threadlocker and Sealant - Blue (Part No. 99642-97) is required for proper installation of this kit.

▲ WARNING

The rider's safety depends upon the correct installation of this kit. Use the appropriate service manual procedures. If the procedure is not within your capabilities or you do not have the correct tools, have a Harley-Davidson dealer perform the installation. Improper installation of this kit could result in death or serious injury. (00333a)

NOTE

This instruction sheet refers to service manual information. A service manual for this year/model motorcycle is required for this installation and is available from a Harley-Davidson dealer.

Kit Contents

See Figure 5 and Table 1.

INSTALLATION

Tour-Pak Lockset Removal

NOTE

See Figure 1. Keep the cam washer (2) on the lock (1). The cam washer can easily slip off of the lock, and is not sold separately.

See Figure 2. The thin washer (8) can be recycled or properly disposed of.

1. Remove the lockset from the Tour-Pak lid per service manual instructions. Note lockset (9) and lock guide (7) orientation before removal from the lid.

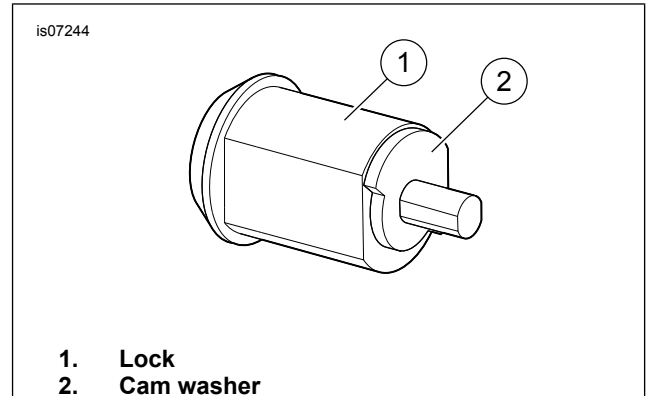

1. Lock
2. Cam washer

Figure 1. Lock and Cam Washer

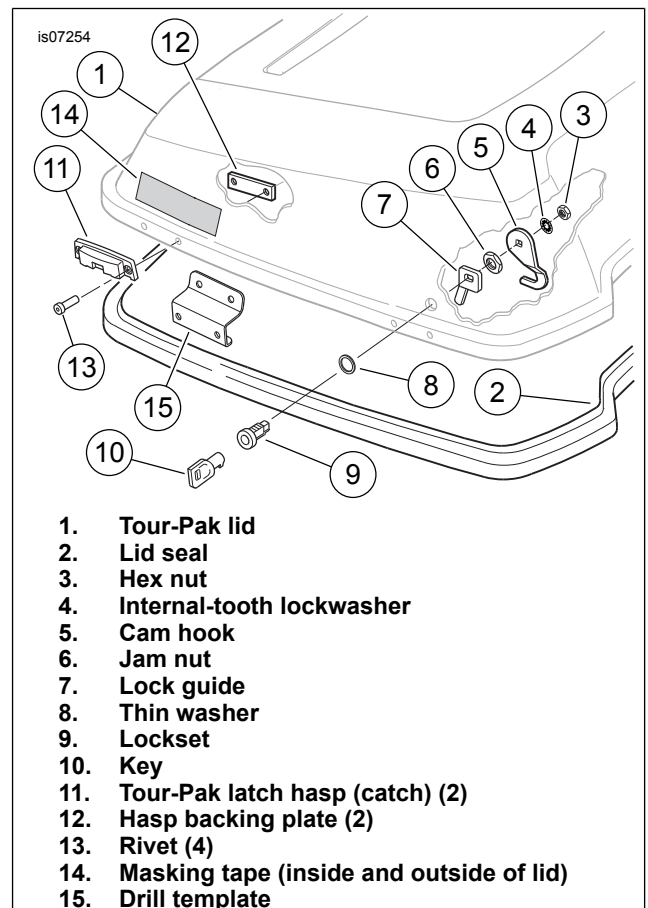

1. Tour-Pak lid
2. Lid seal
3. Hex nut
4. Internal-tooth lockwasher
5. Cam hook
6. Jam nut
7. Lock guide
8. Thin washer
9. Lockset
10. Key
11. Tour-Pak latch hasp (catch) (2)
12. Hasp backing plate (2)
13. Rivet (4)
14. Masking tape (inside and outside of lid)
15. Drill template

Figure 2. Tour-Pak Lid Modification for Premium Latch

Original Equipment (OE) Latch Hasp (Catch) Removal

NOTE

Take care not to damage the Tour-Pak lid (1) or lid seal (2) during the drilling steps.

1. See the service manual. Drill out the rivets (13) to remove the forward and rear OE Tour-Pak latch hasps (11) and backing plates (12) from the right side of the Tour-Pak lid.
2. Place strips of masking tape above the rear hasp area (14) as shown, on the inside and outside of the lid.
3. Horizontally align the lower holes of the drill template (15) with the lid holes revealed by removing the rear hasp.

NOTE

To aid later assembly, the holes should be drilled perpendicular to the template face.

4. Use a 3 mm (1/8 in) bit in the upper template holes to drill two pilot holes in the Tour-Pak lid. Enlarge the holes to final size with a 5 mm (3/16 in) bit.

OE Latch Removal, Tour-Pak Bottom

1. See Figure 3. Remove two TORX® screws (2) and flat washers (3) to release the rear latch (4) and spacer (5) from the right side of the Tour-Pak bottom (1).

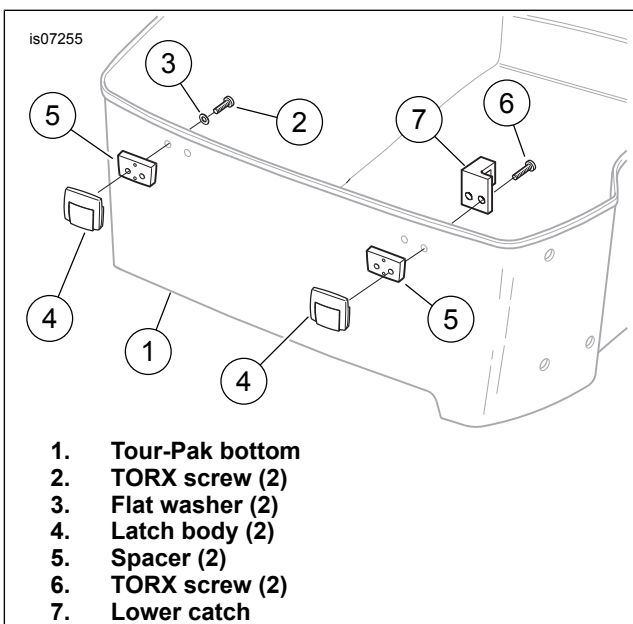

Figure 3. Tour-Pak Bottom Modification for Premium Latch

2. Remove two TORX® screws (6) to release the lower catch (7), front latch (4) and spacer (5) from the Tour-Pak.
3. Save the lower catch, but recycle or properly dispose of the remaining hardware and fasteners
4. Place strips of masking tape over the front and rear latch hole areas, on the inside and outside of the Tour-Pak bottom.
5. Enlarge the holes with a 5 mm (3/16 in) bit.

Premium Latch Installation, Tour-Pak Lid

NOTE

CVO models with power locks do not use the flat washer (11).

NOTE

A bead of silicone caulk (B) may be applied to the back side of the upper forward latch if desired, but care must be taken to not cover the drain hole (C).

1. See Figure 5. Get the upper forward Tour-Pak latch (1) and 6.4 mm (1/4 in) flat washer (11) from the kit, and the lockset removed from the Tour-Pak lid earlier.
2. Position the latch over the lock hole in the lid, with the locating pins (A) in the holes on the lid flange.
3. See Figure 2. Insert the lockset (9) into the upper latch per the service manual.
4. Install the lock guide (7), in the proper orientation. Install the jam nut (6) and tighten per service manual instructions.
5. **For CVO models with power locks:** Assemble the remaining components per the service manual. **For ALL OTHER models:** Follow the service manual to install the cam washer, cam hook (5), flat washer (13) and lockwasher (4) onto the lockset threaded stud in the proper orientation.
6. Apply a few drops of Loctite 243 - Blue to the clean lockset stud threads. Install the hex nut (3) and tighten per the service manual.
7. See Figure 5. Get the upper rear Tour-Pak latch (2), two #8-32 x 16 mm (5/8 in) long pan head screws (9) and two #10 (5 mm) flat washers (8) from the kit.
8. Remove the masking tape placed earlier on the inside and outside of the lid and carefully clean off any adhesive residue with isopropyl alcohol. Allow to dry thoroughly.

NOTE

The latch **MUST** fit properly to the top of the Tour-Pak lid flange. See Figure 4.

If the holes were drilled at too much of an angle, the screws may be difficult to install. This may cause the upper latch to lift away from the flange.

Remedy this situation **before fully engaging the lock patch on the screws** by slightly enlarging the holes **vertically**. Check again for proper fit of the latch to the lid flange.

9. Align the latch over the two holes in the lid, with the locating pins (A) in the holes on the lid flange.

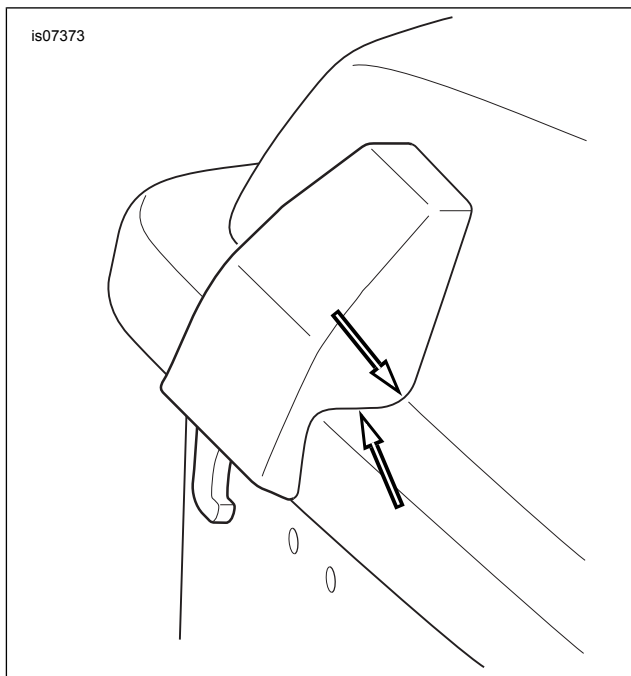

Figure 4. Fit Upper Rear Latch Tightly to Tour-Pak Lid Flange Contour

- Secure the latch to the lid with the screws and washers. Tighten to 2.3–2.8 N·m (20–25 in-lbs).

Premium Latch Installation, Tour-Pak Bottom

- Get a lower Tour-Pak latch assembly (3), two #8-32 x 16 mm ($\frac{5}{8}$ in) long pan head screws (9) and two #10 (5 mm) flat washers (8) from the kit.
- Remove the shipping tape from the lower latch assembly. Remove the masking tape placed earlier on the inside and outside of the saddlebag bottom. Carefully clean off any adhesive residue with isopropyl alcohol. Allow to dry thoroughly.
- Secure the lower latch assembly to the rear location on the outside of the Tour-Pak bottom with the screws and washers, but do not fully tighten.
- Get the remaining lower Tour-Pak latch assembly and two #8-32 x 19 mm ($\frac{3}{4}$ in) long pan head screws (10) from the kit, and the lower catch (see Figure 3, item 7) removed earlier.

- Position the lower latch assembly to the front location on the outside of the Tour-Pak bottom. Position the lower catch to the inside of the Tour-Pak in the same location. Secure with the screws, but do not fully tighten.
- Gently close the lid and press down to latch. Check to make sure the lower latch assemblies are straight, level and have minimal clearance to the upper latch bodies. Mark the lower latch positions on the Tour-Pak bottom with tape.
- Carefully open the lid by depressing the release buttons (D) on both front and rear latches simultaneously. The lid should be pushed open slightly by the spring caps (E).
- Double check the lower latch positions relative to the tape applied in Step 6. Adjust the latches as necessary, then tighten the screws to 2.3–2.8 N·m (20–25 in-lbs).
- Close the lid again to confirm alignment and smooth operation. The lid is properly latched when the release buttons (D) pop out.
- Lock and unlock the Tour-Pak lid with the key to verify proper operation.

IN USE

Latches may require periodic cleaning and lubrication. If the latching mechanism does not operate smoothly or properly engage the upper latch, the lower assembly can be removed from the Tour-Pak bottom and cleaned.

- Open the Tour-Pak lid. See Figure 5. Remove the fasteners to free the lower latch assembly (3) from the Tour-Pak.
- Remove the latch cover (7), catch (6) and catch spring (5).
- Clean all parts thoroughly. If catch is damaged or worn, replace with the Service Kit (Part No. 53000321). Lightly lubricate with a small amount of Harley Lube (Part No. 94968-09) or silicone grease.
- Install the catch spring and catch into the lower latch (4) chamber.
- Install the latch cover, and press the catch release button (D) against the spring to verify proper operation.
- Install the lower latch assembly per the original installation instructions.

SERVICE PARTS

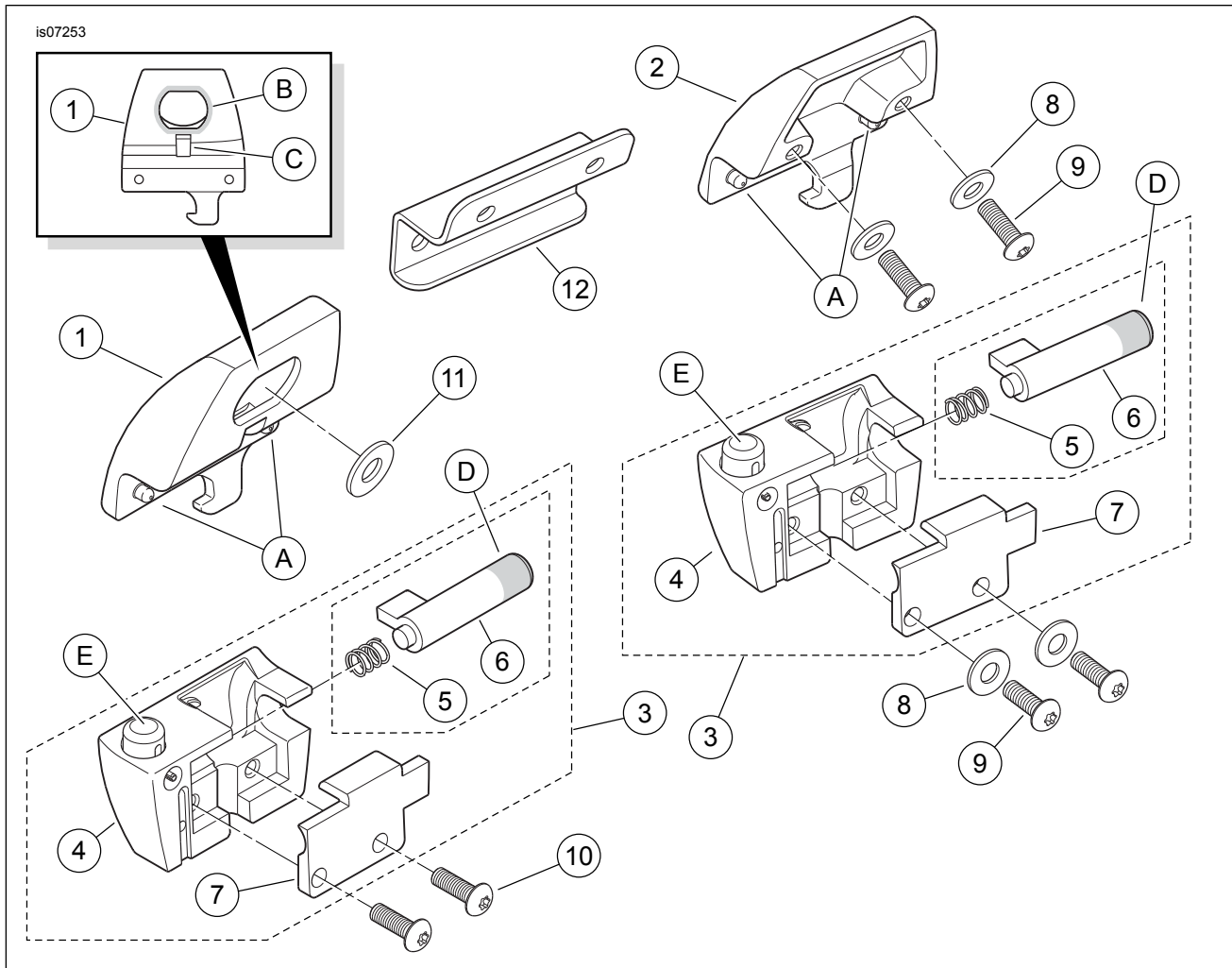

Figure 5. Service Parts, Premium Tour-Pak Latch Kit

Table 1. Service Parts, Premium Tour-Pak Latch Kit

Kit	Item	Description (Quantity)	Part Number
Kit 53000252 Tour-Pak Latch Kit (Chrome)	1	Upper forward Tour-Pak latch (chrome)	Not sold separately
	2	Upper rear Tour-Pak latch (chrome)	Not sold separately
	3	Lower Tour-Pak latch assembly (chrome) (2) (includes items 4-7)	Not sold separately
	4	• Lower Tour-Pak latch (chrome) (2)	Not sold separately
Kit 53000253 Tour-Pak Latch Kit (Black)	1	Upper forward Tour-Pak latch (black)	Not sold separately
	2	Upper rear Tour-Pak latch (black)	Not sold separately
	3	Lower Tour-Pak latch assembly (black) (2) (includes items 4-7)	Not sold separately
	4	• Lower Tour-Pak latch (black) (2)	Not sold separately
Items common to ALL kits	5	• Catch spring, Tour-Pak latch (2) (see Service Kit 5300321)	Not sold separately
	6	• Catch, Tour-Pak latch (2) (see Service Kit 5300321)	Not sold separately
	7	• Cover, Tour-Pak lower latch (2)	Not sold separately
	8	Flat washer, #10 (4)	6716
	9	Machine screw, Phillips pan head, #8-32 x 16 mm (5/8 in) long, with lock patch (4)	2625
	10	Machine screw, Phillips pan head, #8-32 x 19 mm (3/4 in) long, with lock patch (2)	2646
	11	Flat washer, 1/4	6703
Service Kit 53000321	5	Catch spring, Tour-Pak latch	Not sold separately
	6	Catch, Tour-Pak latch	Not sold separately
Items mentioned in text:			
	A	Locating pin on upper latch (4)	
	B	Silicone caulk around opening if desired	
	C	Drain hole	
	D	Release "button" (2) (exposed end of catch, Item 6)	