



INSTRUCTIONS

-J05512

2012-04-17

TOUR-PAK LOCK COVER

GENERAL

Kit Numbers

53000217, 53000218

Models

For model fitment information, see the P&A retail catalog or the Parts and Accessories section of www.harley-davidson.com (English only).

Installation Requirements

NOTE

A service manual for this model/year motorcycle is available from a Harley-Davidson dealer.

Kit Contents

See Figure 6 and Table 1.

DISASSEMBLY - Models without Power Lock

1. See Figure 1 and Figure 2. Open Tour-Pak® and remove jam nut (9), lockwasher (8), cam hook (7), and the lock orientation plate (Figure 1). Be sure to note the orientation of the plate upon removal.

NOTE

Note lock and lock guide (4) orientation before removal from Tour-Pak.

2. Remove nut (5) and lock guide.
3. Withdraw lock (1) and discard washer (3).

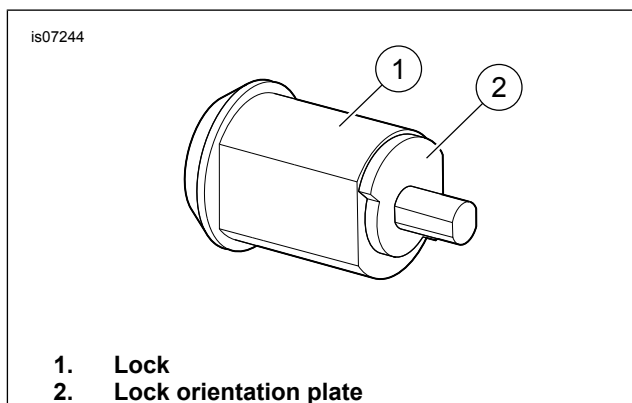

Figure 1. Lock Orientation Plate

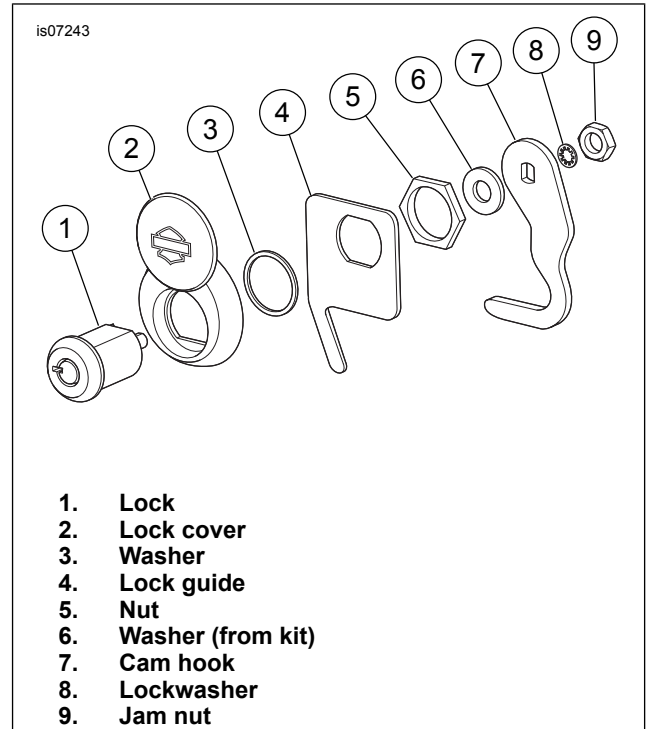

Figure 2. Tour-Pak Lock Cover Installation

DISASSEMBLY - Models with Power Lock

NOTE

Note lockset and latch component orientation before removal from Tour-Pak.

1. Remove the main fuse.
2. Remove the felt liner from Tour-Pak cover.
3. See Figure 3. Remove the fastener (1) holding the latch cover in place.
4. See Figure 4. Remove retaining ring (1) and disconnect cable end from latch.
5. Remove nut and washer (2). Discard washer.
6. Remove latch components (3).
7. Remove nut (4) and remove lockset and washer from cover. Discard washer.



is07265

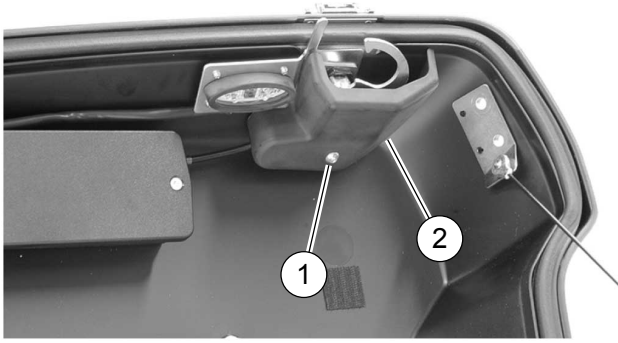

- 1. Fastener
- 2. Latch Cover

Figure 3. Tour-Pak Latch Cover

is07266

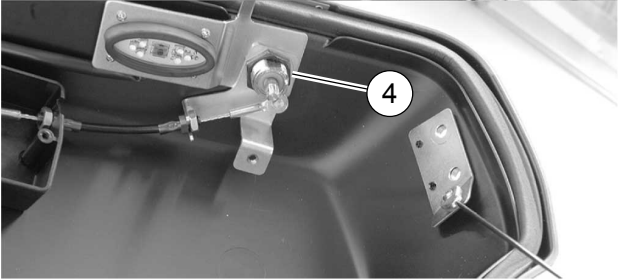
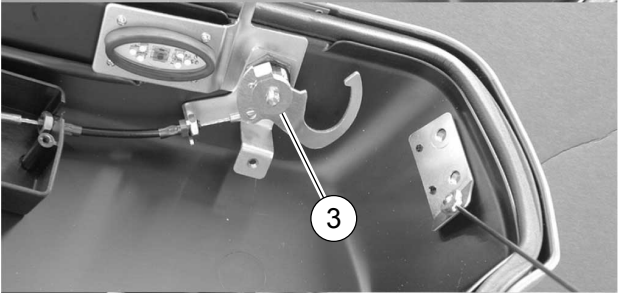
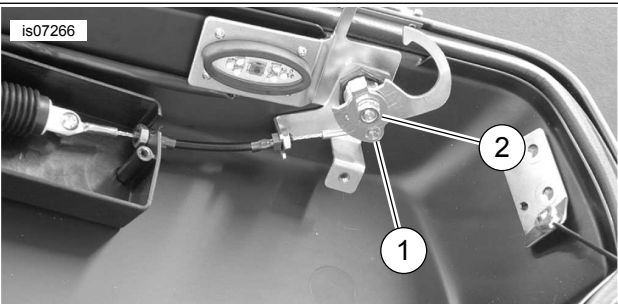

- 1. Retaining ring
- 2. Nut and washer
- 3. Latch components
- 4. Nut

Figure 4. Tour-Pak Lockset

INSTALLATION - Models without Power Lock

1. See Figure 2. Open lock cover (2) and insert lock (1) into cover in same orientation as disassembly.
2. Install lock and cover on Tour-Pak.

NOTE

On some vehicles proper alignment of the cam hook is aided by installing the lockwasher (8) between the lock orientation plate and the washer from the kit (6). Perform a test fitment to confirm.

3. Install lock guide (4) and nut (5). Tighten nut to 3.4–5.1 N·m (30–45 in-lbs).
4. Install lock orientation plate (Figure 1), washer from kit (6), and cam hook (7).
5. Install jam nut (9) using Loctite Medium Strength Threadlocker 243 (blue). Tighten to 2.8–4 N·m (25–35 in-lbs).
6. See Figure 5. Close lid and actuate lock to verify proper alignment.

is07245

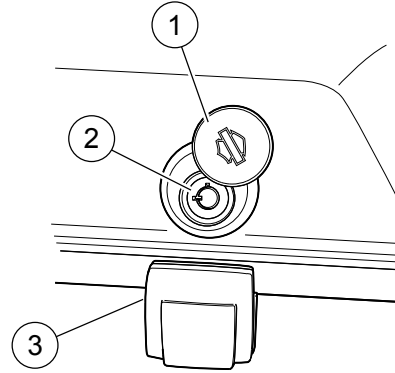

- 1. Lock cover
- 2. Lock
- 3. Latch

Figure 5. Installed Lock Cover

INSTALLATION - Models with Power Lock

1. Open lock cover and insert lock into cover in same orientation as disassembly.
2. Install lockset and cover on Tour-Pak.
3. See Figure 4. Install nut (4). Tighten to 3.4–5.1 N·m (30–45 in-lbs).
4. Install latch components (3) and secure with nut and washer (2). Tighten to 2.8–4 N·m (25–35 in-lbs).
5. Connect cable end to latch hook and retain with retaining ring (1).
6. See Figure 3. Install the latch cover and secure with fastener (1).
7. Install felt liner.
8. Install main fuse and test power lock operation.

SERVICE PARTS

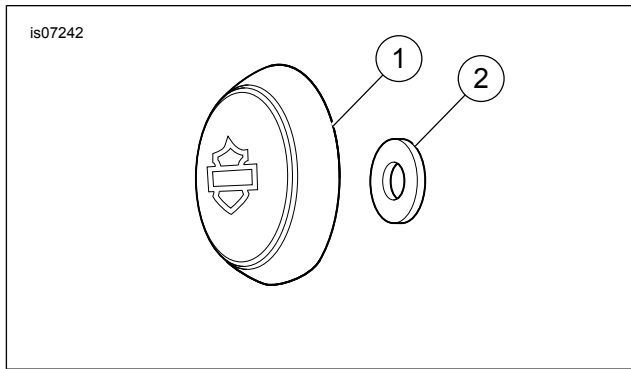

Figure 6. Service Parts: Tour-Pak Lock Cover

Table 1. Service Parts Table

Item	Description (Quantity)	Part Number
1	Lock cover	Not sold separately
2	Washer	6703