



INSTRUCTIONS

-J04664

REV. 2008-07-02

LUGGAGE RACK

GENERAL

Kit Number

52796-09

Models

For model fitment information, see the P&A Retail Catalog or the Parts and Accessories section of www.harley-davidson.com (English only).

Additional Parts Required

WARNING

The rider's safety depends upon the correct installation of this kit. Use the appropriate service manual procedures. If the procedure is not within your capabilities or you do not have the correct tools, have a Harley-Davidson dealer perform the installation. Improper installation of this kit could result in death or serious injury. (00333a)

NOTE

This instruction sheet references service manual information. A service manual for your model motorcycle is required for this installation and is available from a Harley-Davidson Dealer.

A 3 mil thick plastic sheet or bag approximately 18 in x 48 in (46 cm x 123 cm) is required for this kit installation.

For Models with Denim Paint: 3M Adhesive Remover or equivalent.

For All Other Paint: Harley Glaze Polish and Sealant (99701-84).

Kit Contents

Table 1. Kit Contents

Description (Qty)	Part Number
Rack, solo rigid	Not Sold Separately
Tape, double-sided foam (2)	53791-06
Dowel pin (4)	Not Sold Separately

REMOVAL

NOTE

See service manual for specific information for these generalized steps.

- See Figure 1. Remove the reflector (8) from the rear fender. Use dental floss (or equivalent) and a sawing motion if necessary to remove reflector. Repeat for the other side.

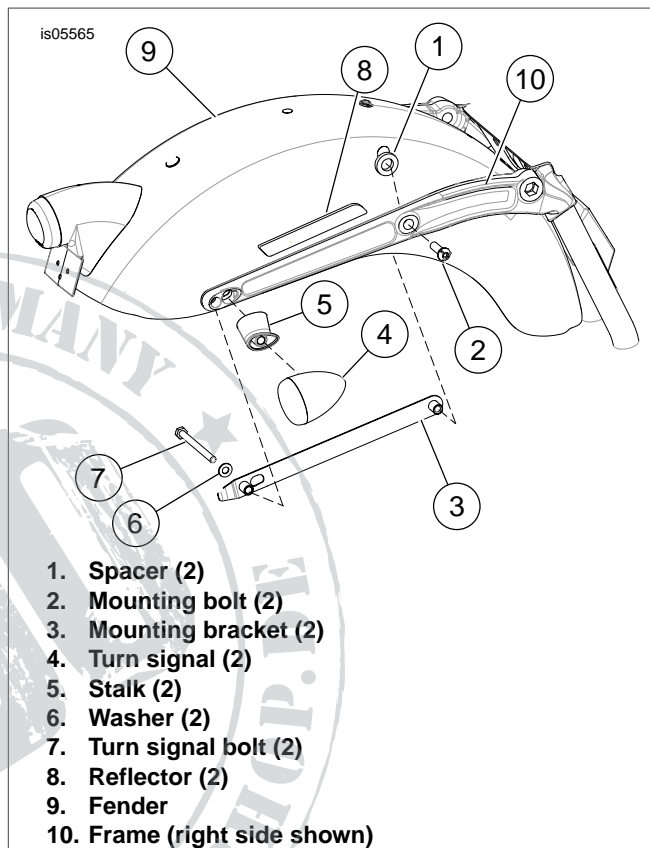

Figure 1. Remove Fender Components

- Cover the belt guard and brake components with shop rags. Follow the manufacturer's instructions for the adhesive remover or Harley Glaze and remove all traces of remaining adhesive. Do not allow adhesive remover to drip onto the belt or brake components.
- Support the vehicle and raise the rear tire slightly off the ground.
- See Figure 2. Remove the lower shock bolt (1) from each shock.
- See Figure 1. Remove the turn signal bolt (7) and lower the turn signal (4) and stalk (5) as an assembly. Repeat for other side.
- Remove the mounting bolt (2).
For Non-FXDB Models: Remove the fender strut cover. Repeat for other side.
- Support the fender (9) and remove the mounting bracket (3) from inside the fender. Gently lower the fender away from the frame (10) being careful not to damage the paint. Squeeze the fender slightly if necessary to lower the fender between the arms of the frame.

8. Fold the plastic sheet or bag (purchased separately) in half and lay it over the fender to protect the paint. Make sure the plastic covers the six rack mounting holes in the frame.
9. Remove the spacers (1) from the fender. If necessary, use dental floss or equivalent to remove the spacers.

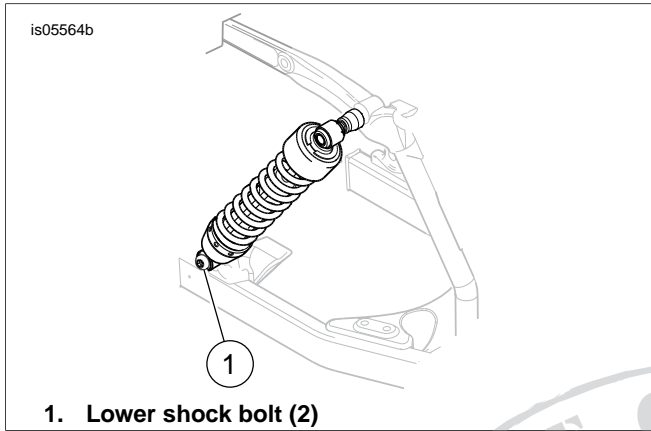

Figure 2. Remove Lower Shock Bolt (Right Side Shown)

INSTALLATION

1. See Figure 3. Install the spacer (3) on the outside of the front mounting hole of the rack (4). There should be enough adhesive residue to allow the spacer to temporarily adhere to the rack. Repeat for the other side.
2. Gently position the rack inside the frame. Verify that the spacers are still aligned with the mounting holes (4) and the turn signal wires are routed through the slots of the rack (2). Insert two dowel pins through the mounting holes in the rack, through the spacer and frame to hold the rack in place. Insert two dowel pins into the rear mounting holes (1) and through the frame. Do not pinch the turn signal wires with the dowel pins.
3. Gently raise the fender into position, squeezing it slightly if necessary. Use the dowel pins to hold it in place.
4. See Figure 1. Install the mounting bracket (3) from the inside of the fender and align with the dowel pins. Push the legs of the mounting bracket through the mounting holes and plastic sheeting or bag, driving the dowel pins out.
5. **For Non-FXDB Models:** Install fender strut cover and mounting bolt (2). Tighten the mounting bolt finger-tight. Repeat for other side.
For FXDB Models: Install the mounting bolt and tighten finger-tight. Repeat for other side.
6. Install the turn signal bolt (7), washer (6) and turn signal stalk (4) and assembly (5). Tighten bolt finger-tight.
7. Remove plastic sheet.
8. Tighten the turn signal bolts and mounting bolts to 12-16 ft-lbs (16-22 Nm). Repeat for the other side.
9. Install the lower shock nut, bolt and washer. Tighten to 30-40 ft-lbs (41-54 Nm). Repeat for other side.

WARNING

Be sure that all lights and switches operate properly before operating motorcycle. Low visibility of rider can result in death or serious injury. (00316a)

10. Test turn signals for proper operation.

NOTE

If desired, new reflectors can be purchased from a Harley-Davidson dealer.

11. See Figure 4. Clean the back of the reflector, apply double-sided foam tape from the kit and install the reflector (1) on the fender. Repeat for the other side.

WARNING

Do not exceed luggage rack weight capacity. Too much weight can cause loss of control, which could result in death or serious injury. (00373a)

NOTE

Maximum luggage rack weight capacity is 25 pounds (11.3 kg).

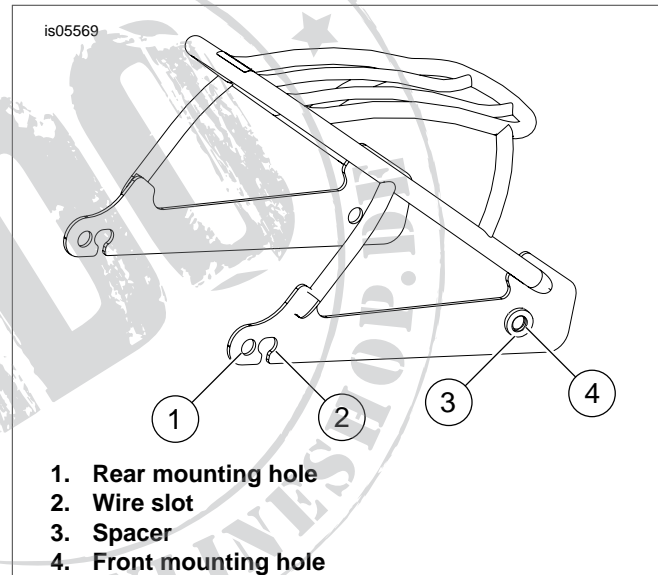

Figure 3. Rack Mounting

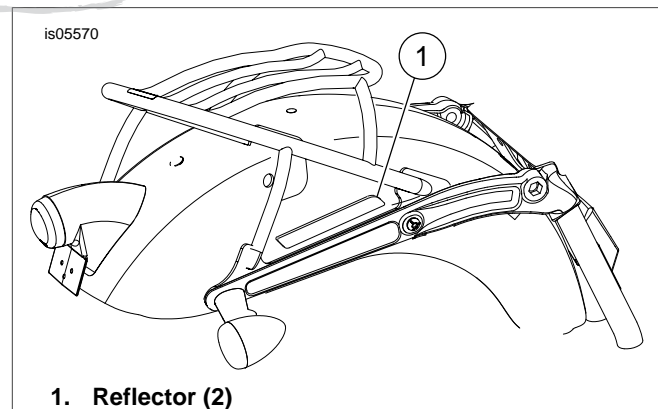

Figure 4. Install Reflector