



# INSTRUCTIONS

-J05436

REV. 2011-05-20

## TOURING PILLION

### GENERAL

#### Kit Number

52400040

#### Models

For model fitment information, see the P&A Retail Catalog or the Parts and Accessories section of [www.harley-davidson.com](http://www.harley-davidson.com) (English only).

### WARNING

The rider's safety depends upon the correct installation of this kit. Use the appropriate service manual procedures. If the procedure is not within your capabilities or you do not have the correct tools, have a Harley-Davidson dealer perform the installation. Improper installation of this kit could result in death or serious injury. (00333a)

#### Kit Contents

See Figure 2 and Table 1.

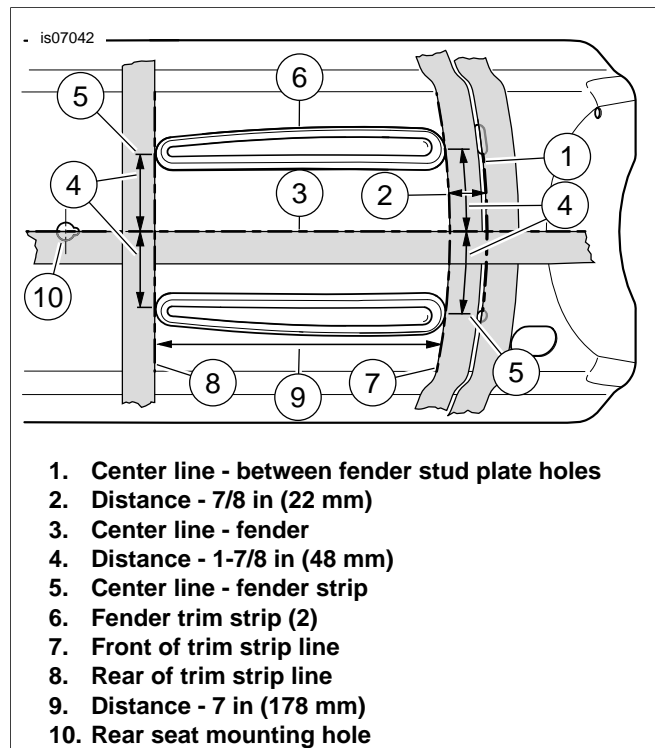

Figure 1. Determine Fender Strip Location

### INSTALLATION

#### Install Fender Trim Strips

1. Clean the fender where the trim strips will be located with an approximately 1:1 solution of distilled water and isopropyl alcohol. Allow to dry completely.
2. See Figure 1. The fender trim strips are located 7/8 in (22 mm) back from the center of the rear fender stud plate holes. The center line of each fender trim strip is 1-7/8 in (48 mm) to the left and right of the fender center line. The following procedure can be used to determine the fender trim strip mounting locations:
  - a. Lay a piece of masking tape along the center line (1) between the two fender stud plate holes.
  - b. Measure the distance between the two stud plate holes and then mark the center point between them. This is the center of the fender.
  - c. Lay a piece of masking tape from the center of the rear seat mounting hole (10), along the fender center line, to the center point marked in step b. This is the fender center line (3).
  - d. Lay a piece of tape parallel and 7/8 in (22 mm) (2) to the rear of the center line (1) marked in step a. This will mark the front of the trim strip mounting location (7).
  - e. Lay a piece of tape parallel and 7 in (178 mm) to the rear of the tape line marked in step d. This will mark the rear of the trim strip mounting location (8).
  - f. Mark a point 1-7/8 in (48 mm) (4) to the left and right of the fender center line (3) on the tape from steps d and e. These mark the center points for the front and rear of each trim strip (5).
3. Without removing the protective backing from the trim strips, lay the trim strips in the positions marked on the fender. Verify that the positions appear parallel and evenly placed on the fender.
4. Remove the protective backing from the trim strips and apply the trim strips to the fender in the marked positions.
5. Remove the masking tape from fender and clean off any residue.

#### Install Pillion

1. See Figure 2. If installed, remove seat mounting nuts (B) and the solo seat (A).
2. Install grab strap (2) onto the studs where the seat mounting nuts were removed.
3. Install the solo seat (A) and seat mounting nuts (B) over the grab straps.

4. Install touring pillion, through the grab strap (2), to the seat mounting nuts by sliding the two slots in the pillion base into the grooves on the seat mounting nuts. Verify that the tab at the front of the seat engages the slot.

**⚠ WARNING**

After installing seat, pull upward on seat to be sure it is locked in position. While riding, a loose seat can shift causing loss of control, which could result in death or serious injury. (00070b)

**NOTE**

If the stock seat mounting hardware is no longer available, a Detachable Seat Hardware Kit (Part No. 51676-97A) is available for separate purchase.

5. Secure the rear of the pillion to the fender using the stock seat mounting hardware (C) from the stock two-up seat.

**Remove Pillion**

1. See Figure 2. Remove seat mounting hardware at the rear of the pillion (C).
2. Pull pillion (1) to the rear to disengage it from the seat mounting nuts.
3. If necessary, remove seat mounting nuts (B) and solo seat (A), then remove the grab strap (2).

**⚠ WARNING**

After installing seat, pull upward on seat to be sure it is locked in position. While riding, a loose seat can shift causing loss of control, which could result in death or serious injury. (00070b)

4. Install solo seat and seat mounting nuts over studs. Verify that the tab at the front of the seat engages the slot in the frame.
5. Cover the seat mounting nuts with the leather flap at the rear of the seat.
6. Remove the chrome cap (4) from the bottom of the pillion and install it into the pillion mounting hole in the fender.

**SERVICE PARTS**

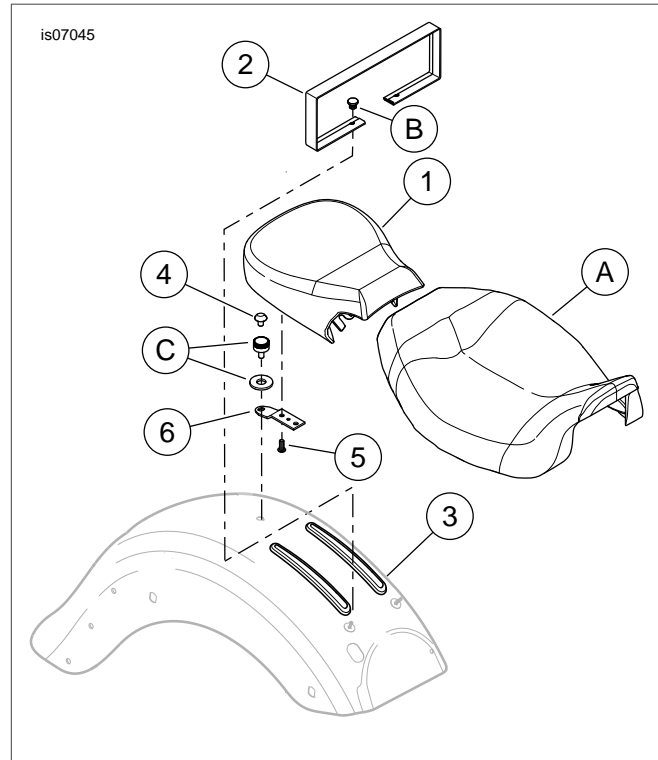

Figure 2. Service Parts: Touring Pillion

Table 1. Service Parts

| Item   | Description (Quantity)            | Part Number         |
|--|-----------------------------------|---------------------|
| 1  | Pillion                           | Not Sold Separately |
| 2  | Grab strap, brown                 | 52400027            |
| 3  | Trim strip, fender (2)            | 11100024            |
| 4  | Cap, plastic (chrome)             | 762                 |
| 5  | Screw, TORX, 1/4-20 x 0.62 in (2) | 941                 |
| 6  | Bracket, seat mounting            | 51652-97A           |
| <b>Items mentioned in text, but not included in kit.</b> |                                   |                     |
| A  | Solo seat                         |                     |
| B  | Seat mounting nut (2)             | 3633                |
| C  | Seat mounting hardware            | 51676-97A           |

