



INSTRUCTIONS

-J05567

2012-06-29

DETACHABLE SADDLEBAG DOCKING POINT KIT

GENERAL

Kit Number

52300243

Models

For model fitment information, see the P&A Retail Catalog or the Parts and Accessories section of www.harley-davidson.com (English only).

Additional Parts Required

This kit is a docking kit expansion and requires components from docking kit 52300239 for proper installation. Installation of this kit will allow the installation of both detachable saddlebags and detachable sideplates.

▲ WARNING

The rider's safety depends upon the correct installation of this kit. If the procedure is not within your capabilities or you do not have the correct tools, have a Harley-Davidson dealer perform the installation. Improper installation of this kit could result in death or serious injury. (00308a)

Kit Contents

See Figure 1 and Table 1.

REMOVAL

If Saddlebag Kit and Docking Point Kit was Previously Installed

1. Remove saddlebags from the motorcycle following the saddlebag instructions.
2. See Figure 1. Remove screws (K and L) docking points (J and I) and conical docking spacers (H). Make note of docking point locations and conical spacer orientation.
3. Remove nut (C), split washer (D), mini docking point (B) and screw (E) from bracket (A). Leave bracket (A) installed on the motorcycle.
4. Remove and discard the docking spacer (F) and screw (G).

If Saddlebag Kit and Docking Point Kit was NOT Previously Installed

1. See Figure 1. Replace screws (K and L) with screws (4 and 5) from this kit.
2. Replace screw (E) with screw (3) from this kit.
3. Remove and discard the docking spacer (F) and screw (G) from the saddlebag kit.

INSTALLATION

1. See Figure 1. Install screw (4), mini docking point (1), mini docking point (I) and conical spacer (H) into the forward strut mounting location. Tighten to 28.5–36.6 N·m (21–27 ft-lbs).
2. Install screw (5), mini docking point (1), wide docking point (J) and conical spacer (H) into the rear strut mounting location. Tighten to 28.5–36.6 N·m (21–27 ft-lbs).
3. Install screw (3), mini docking point (B) and spacer (2) to the 3rd-point mount bracket (A). Secure with lockwasher (D) and nut (C). Tighten to 28.5–36.6 N·m (21–27 ft-lbs).

NOTE

The inner set of upper docking points are used for detachable sideplate installation.

4. Repeat procedure for the opposite side of the motorcycle.

▲ WARNING

Check that saddlebags are completely engaged by pulling lower portion of saddlebag outward (away from bike) after installation. If saddlebags are not completely engaged, they can fall off while riding and cause loss of control, which could result in death or serious injury. (00074a)

5. Install saddlebags to outer set of docking points and to 3rd-point support docking point as instructed in the saddlebag instructions.



SERVICE PARTS

is07315a

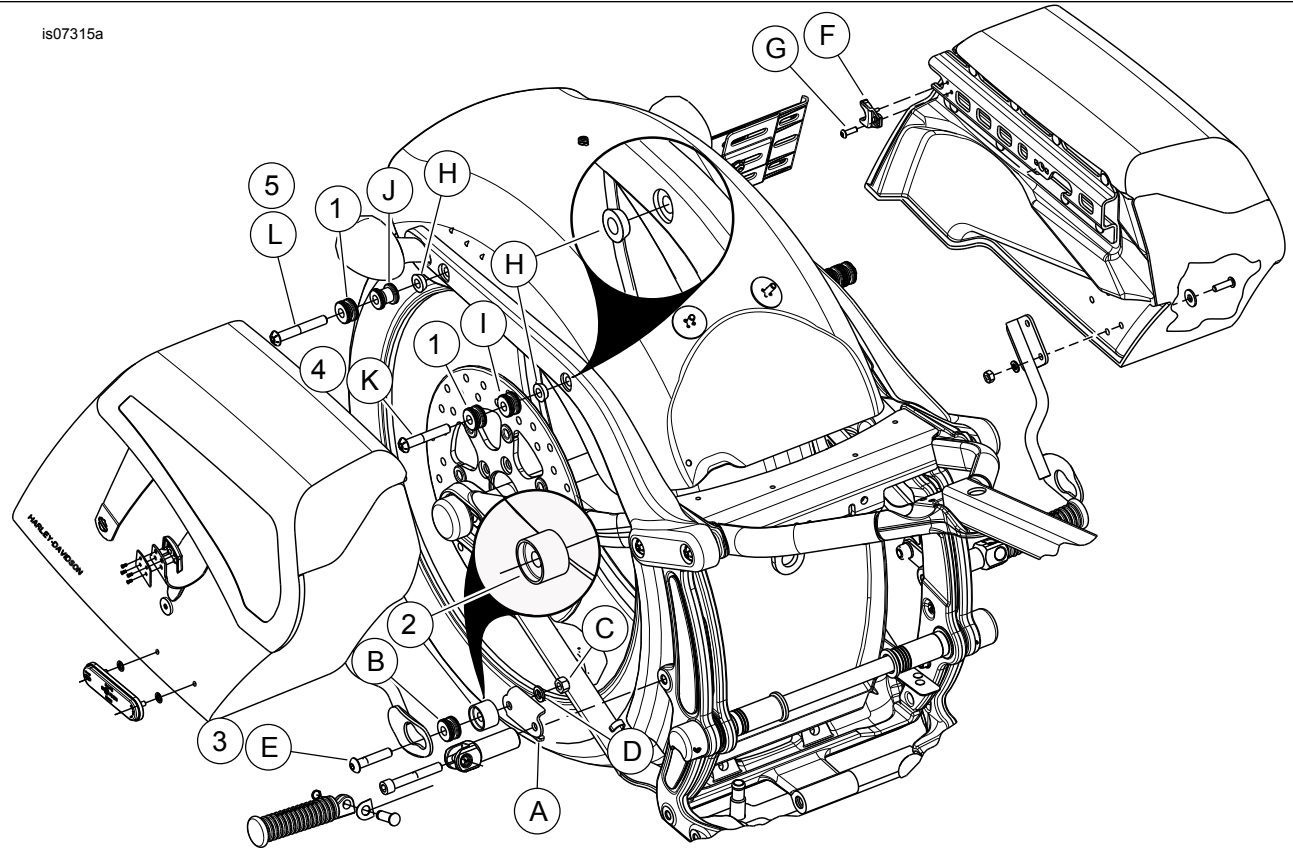

Figure 1. Service Parts: Detachable Saddlebag Docking Point Kit (Part No. 52300243)

Table 1. Service Parts Table

Item	Description (Quantity)	Part Number
1	Docking point, mini (4)	53967-06
2	Spacer, 3 RD -point offset (2)	52300244
3	Screw, button head, 3/8-16 X 1-3/4 in (2)	4246
4	Screw, button head, 3/8-16 X 2-1/4 in (2)	10200214
5	Screw, button head, 3/8-16 X 2-1/2 in (2)	10200045
Items found in Saddlebag Kit:		
A	3 rd Point mount bracket (2)	90200782
B	Docking point, mini (2)	53967-06
C	Nut, hex, 3/8-16 in (2)	7783
D	Lockwasher, split (2)	7038
E	Screw, button head, 3/8-16 X 1-1/4 (2)	4098
F	Docking spacer adapter (2)	88251-07
G	Screw, button head, #10-24 X 5/8 in (2)	4620
Items found in Inner Docking Kit 52300239:		
H	Conical docking spacer (4)	Not Sold Separately
I	Docking point, mini (2)	53967-06
J	Docking point, wide (2)	53684-96A
K	Screw, button head, 3/8-16 X 1-3/4 in (2)	4246
L	Screw, button head, 3/8-16 X 2 in (2)	4118