



# INSTRUCTIONS

-J05320

REV. 2011-06-08

## PREMIUM ADJUSTABLE SIDEPLATES

### GENERAL

#### Kit Number

53994-11, 52300001, 52300003, 52300090, 52300096, 52300110, 52300116

#### Models

For model fitment information, see the P&A Retail Catalog or the Parts and Accessories section of [www.harley-davidson.com](http://www.harley-davidson.com) (English only).

#### NOTE

*This kit is designed to be used ONLY with Genuine Harley-Davidson sissy bar uprights.*

#### Additional Parts Required

Loctite® 243 Threadlocker and Sealant - blue (Part Number 99642-97) is required for the proper installation of this kit.

### WARNING

The rider's safety depends upon the correct installation of this kit. Use the appropriate service manual procedures. If the procedure is not within your capabilities or you do not have the correct tools, have a Harley-Davidson dealer perform the installation. Improper installation of this kit could result in death or serious injury. (00333a)

#### Kit Contents

See Figure 7 and Table 1.

### INSTALLATION

1. See Figure 1. While standing behind the motorcycle, place the left-side and right-side front sideplate notches (2) into the front docking points (4) on the fender supports (3).

See Figure 2 for views of correct and incorrect sideplate engagement.

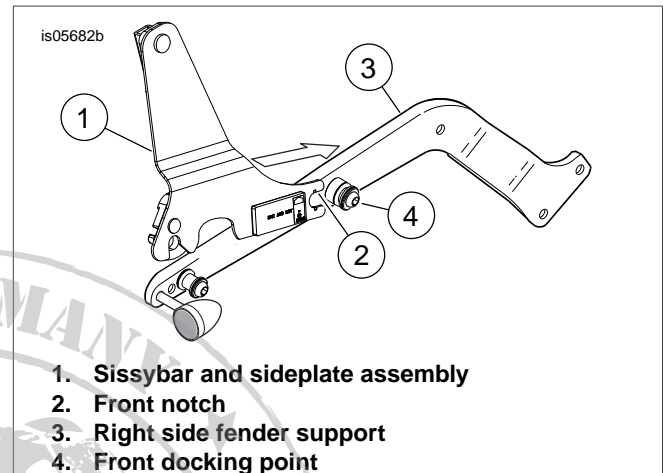

Figure 1. Place Front Notches into Front Docking Points

#### NOTES

*Failure to properly align the front docking points and sideplates may result in damage to the rear docking points.*

**DO NOT** attempt to adjust the sideplates while the motorcycle is in motion.

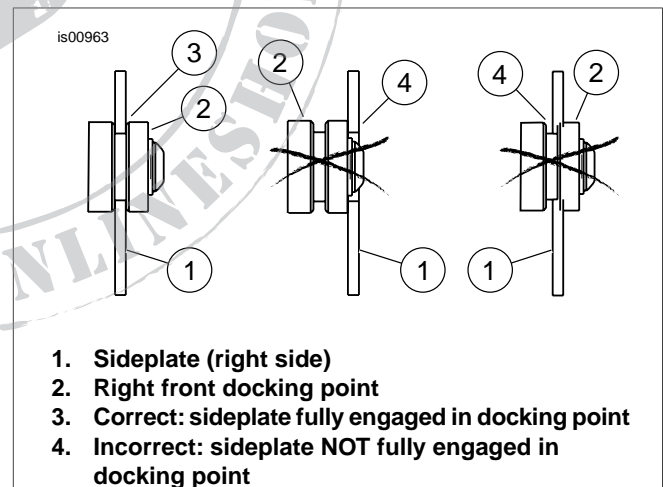
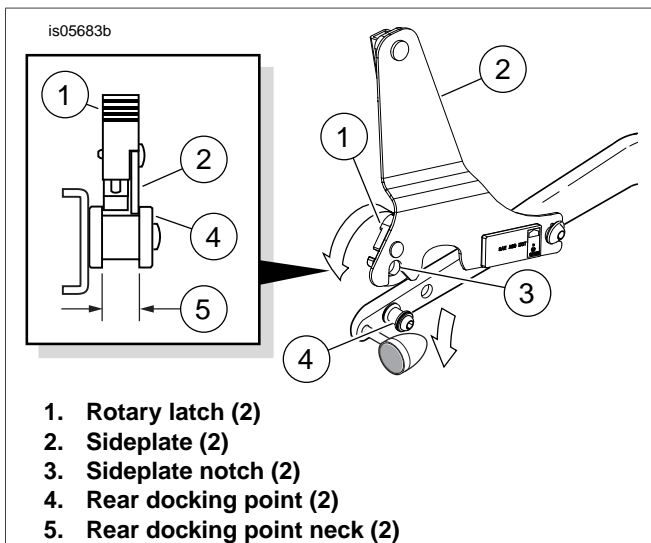

Figure 2. Sideplate Fit to Front Docking Points

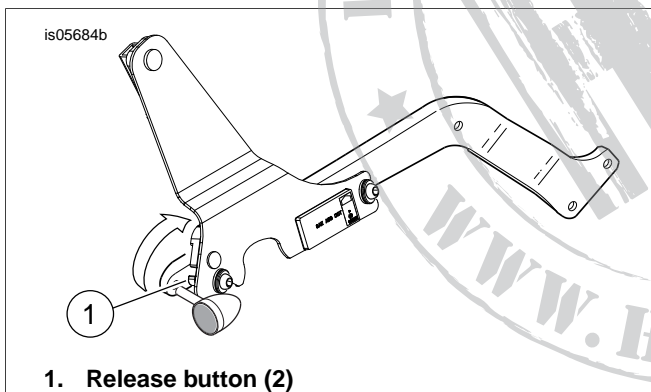

**Figure 3. Lower Rear Notches Onto Rear Docking Points**

2. See Figure 3. Position the rotary latches (1) over the rear docking points (4). Pull the rotary latches (1) back to their rearmost position as shown.

Check to be sure the sideplate notches (3) and latches fit into the neck (5) of the rear docking points as shown. This may require some gentle squeezing or spreading of the sideplates (2).

3. Push the rear of the sideplates downward and close the rotary latches by pressing the latch levers as far forward as they will go (see Figure 4). A "CLICK" will be heard when the latches are in place. If the latches do not easily close, do not force.



**Figure 4. Close Rotary Latches**

4. See Figure 6. Insert the legs of the sissybar upright (4) all the way into the channels (3) of the sideplates as shown.

5. Apply a few drops of Loctite to the threads of the button head screws (4).

Thread the screws into the holes in the sideplate channels, and tighten to 96-120 **in-lbs** (11-14 N-m).

6. To remove the sissy bar and sideplate as an assembly, press to release the rotary latches (7) on each side and pull the latch levers back. Carefully lift the rear of the sideplates up and pull the sissy bar assembly out of the front docking points.

7. See Figure 5. For 2007-Later FLSTF models only: Insert washers (item 3 in table 1) between front and rear docking

points and fender rail covers. Apply Loctite to screw threads and torque to 21-27 ft-lbs (28.4-36.6 Nm).

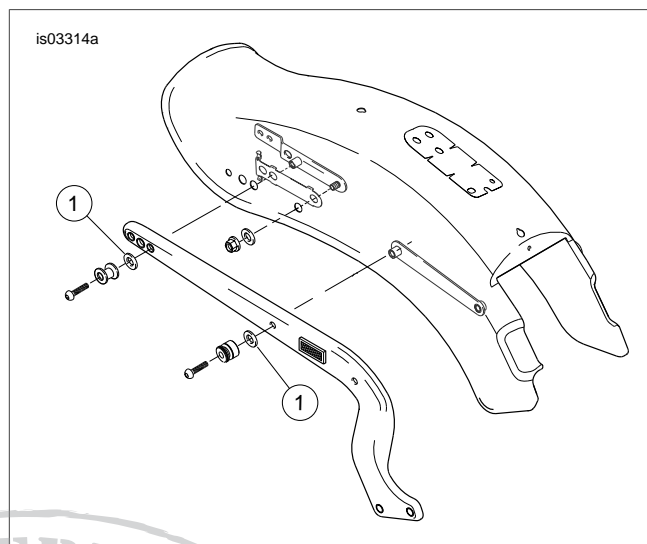

**Figure 5. FLSTF: Add Washers Between Docking Points and Fender Covers**

## ADJUSTING RECLINE ANGLE

1. See Figure 6. To adjust the sissybar, first press the locking tabs (2), then lift the adjustment levers (1) and rotate the sissybar to the desired position. Push the adjustment levers back into their locked positions.

### NOTES

*A "click" will be heard when the lock tabs engage again. In addition, the lock tab should be clearly visible in front of the adjustment lever when the lock is engaged.*

**Check that the two adjustment levers are in a full down position after adjusting the sissy bar.**

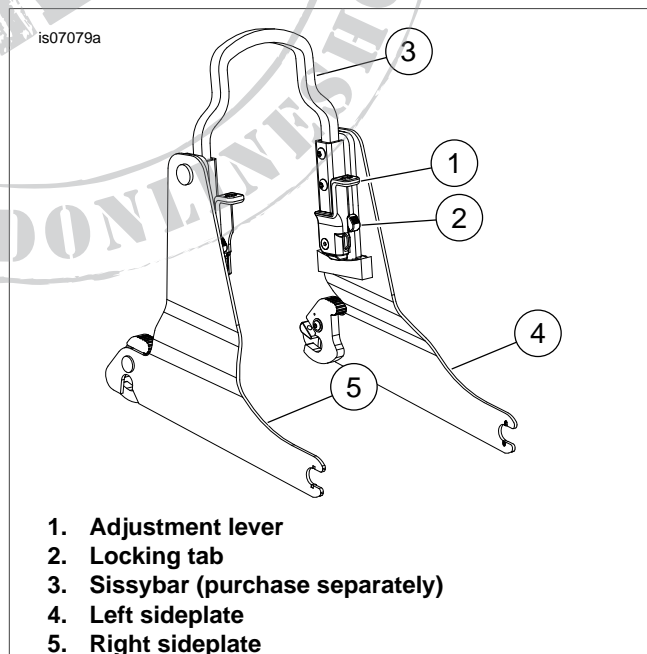

**Figure 6. Sideplate Adjustments**

# SERVICE PARTS

Table 1. Service Parts

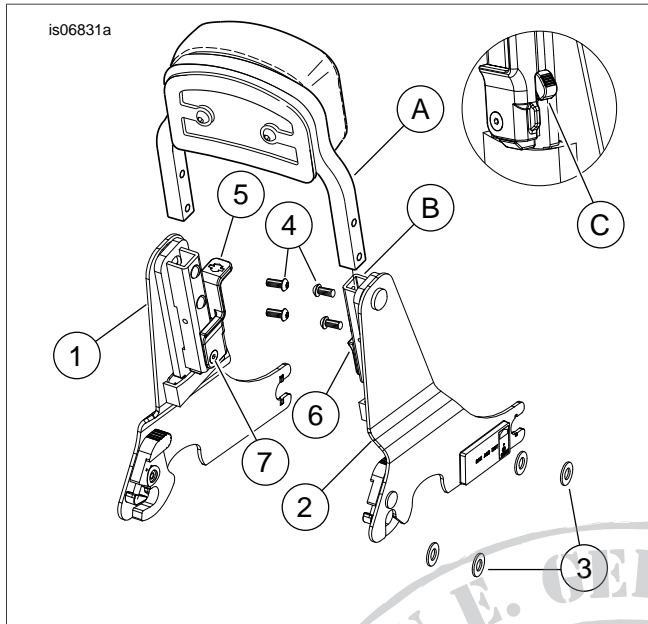

Item	Description (Quantity)	Part Number
1	Side plate, left	Not Sold Separately
2	Side plate, right	Not Sold Separately
3	Flat washer, chrome (4)	Not Sold Separately
4	Button head cap screw, TORX® (4)	Not Sold Separately
5	Lever, sideplate adjustment, left	52300078
6	Lever, sideplate adjustment, right	52300002
7	Screw	10200037
<b>Items mentioned in text, but not included in kit.</b>		
A	Sissy bar upright	
B	Channel in sideplate	
C	Locking tab	

Figure 7. Service Parts: Adjustable Sideplates

