



# INSTRUCTIONS

-J01140

REV. 04-06-00

Kit Number 52069-98

## DIAMOND BACK PILLION

### General

This kit is designed for installation in conjunction with an appropriate Diamond Back seat. This kit is designed for installation on 1983 and later XL's and 1984 and later Softails, except FXSTD.

See Service Parts on page two for kit contents.

### Installation

#### NOTE

A Service Manual for your motorcycle is available from your Harley-Davidson Dealer.

1. Refer to applicable Service Manual and remove seat and grab strap. Save seat mounting hardware for reinstallation.

#### CAUTION

Failure to use the supplied pillion gasket may result in damage to rear fender.

2. Attach the rear mounting bracket from the stock seat to the pillion using the stock hardware.
3. Remove adhesive backing from the pillion gasket (2). Place gasket on the underside of the pillion, leaving the metal bracket exposed. Press gasket firmly onto pillion.

4. See Service Parts Illustration. Attach pillion to seat using the screws saved from Step 1 (if you are installing your Diamond Back Seat for the first time, you should use the screws provided in that kit) and lockwashers (4) from pillion kit. Use the side to side holes in the pillion bracket as shown.
5. Attach grabstrap to motorcycle frame as shown in Service Parts Illustration.

**1996 and earlier XL models:** attach the grabstrap (9) with the hex cap screw (7) and washer (5) as shown.

**1997 and later XL models:** attach the grabstrap (9) with the button head screw, (8) and washer (5) as shown.

**Softail models:** attach the grabstrap (9) as shown using the 4 washers (6) and existing screws.

6. Slide pillion under grab strap and position seat with pillion on frame. Slide seat forward so flat bracket on front of seat engages bracket on frame.

#### WARNING

After installing seat, pull upward on front of seat to be sure it is locked in position. If seat is loose, it could shift position during vehicle operation, resulting in loss of control of vehicle and death or serious injury.

7. Mount pillion to the fender using the stock rear seat screw.



# Service Parts

Part No. 52069-98

Date 11/97

Pillion Kit

## Grab strap attachment on Softail models

## Grab strap attachment on XL models

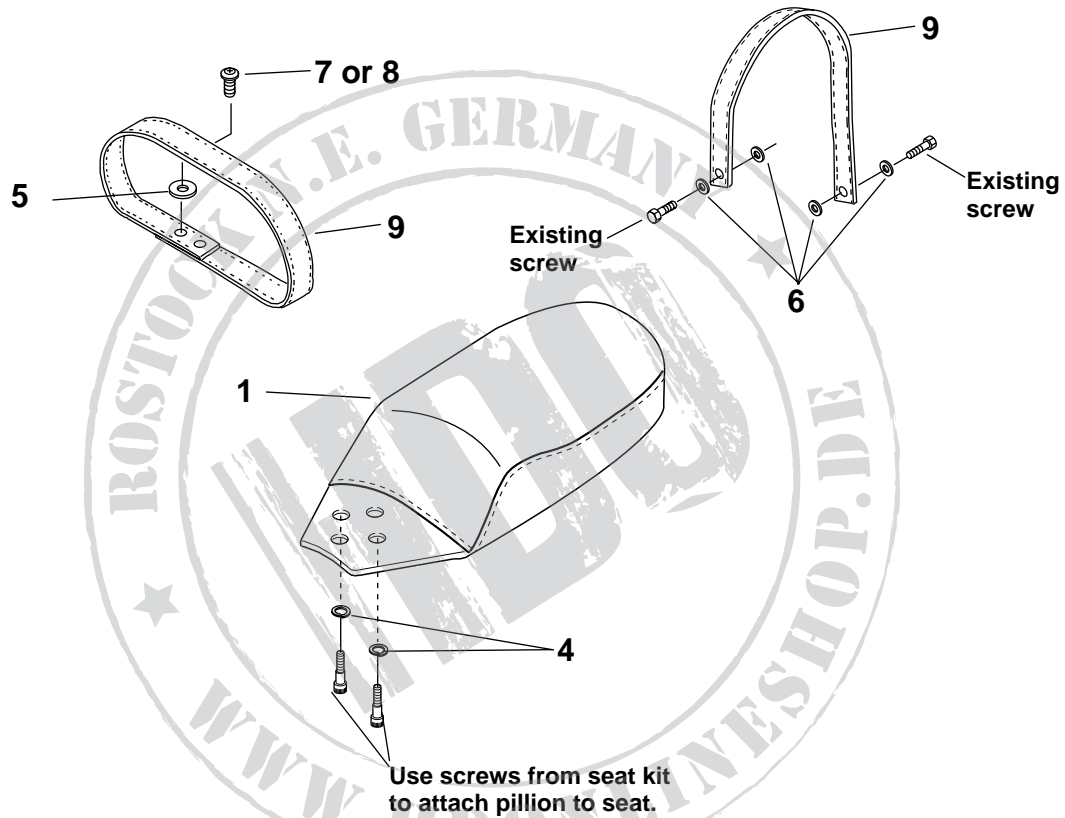

Item	Description	Part No.	Item	Description	Part No.
1	Pillion	Not sold	7	Screw, hex cap (1996 and earlier XL models only)	3765
2	Pillion gasket (not shown)	52071-98	8	Screw, button head (1997 and later XL models only)	94387-92T
3	Hardware kit (Items 4-9 make-up hardware kit)	51797-98	9	Grabstrap	Not sold
4	Lockwasher (2)	7036			
5	Washer, flat (1) (XL models only)	6036			
6	Washer (4) (Softails only)	6333			