



# INSTRUCTIONS

-J06349

2015-11-06

## DYNA SOLO SEAT KIT

### GENERAL

#### Kit Numbers

52000266

#### Models

For model fitment information, see the P&A Retail Catalog or the Parts and Accessories section of [www.harley-davidson.com](http://www.harley-davidson.com) (English only).

#### Kit Contents

See Figure 4 and Table 1.

#### Installation Requirements

**Separate purchase** of more parts or accessories may be required for proper installation of this seat to your model motorcycle. Refer to the latest P&A Retail Catalog for a list of required parts or accessories for your model.

#### ▲ WARNING

**The rider's safety depends upon the correct installation of this kit. If the procedure is not within your capabilities or you do not have the correct tools, have a Harley-Davidson dealer perform the installation. Improper installation of this kit could result in death or serious injury. (00308a)**

#### NOTE

*When a solo seat is installed without a passenger seat, the passenger footpegs or footboards and the passenger grab strap must be removed.*

### REMOVAL

#### NOTE

*Avoid scratching painted surfaces with tools or metal seat tabs.*

1. Remove currently installed seat following the instructions in the owner's manual.
2. **For Models with Solo Seat:** Proceed to step 4.
3. **For Models with two-up Seat:** At the rear seat mounting hole (1), remove the retention washer (10) from the seat retention nut (9). From the underside of the fender, remove the seat retention nut from the vehicle. Insert the Bar & Shield hole plug into the rear seat mounting hole. Remove the grab strap and all attaching hardware.
4. See Figure 1. Obtain the cable strap (3) from the kit.
  - a. Place the retention nut (1) over the cable strap (3) so the wide end of the nut rests on the eye of the cable strap.

- a. Thread the cable strap up under the fender and through the front seat mounting hole (3).
  - b. Pull up on the cable strap to hold the nut snug against the underside of the fender.
  - c. With the rib on the retention nut seated into the notch in the fender hole, slide the retention washer (2) into place from the rear locking the retention nut in place. Remove cable strap.
  - d. **For 2010 and Later FXDWG Models:** Verify that the head of the retention nut is clear of the wire guide.
6. See Figure 3. **For Models with two-up Seat:** Remove the four foam squares (1) from the fender. **For Models with Solo Seat:** Remove the two foam squares (2) from the fender.
  7. Remove any adhesive residue remaining on the fender with a general-purpose adhesive remover (3M™ 051135 or equivalent). Rinse with clear water and dry thoroughly with a clean white cloth. Clean surfaces with isopropyl alcohol. Allow to dry completely.

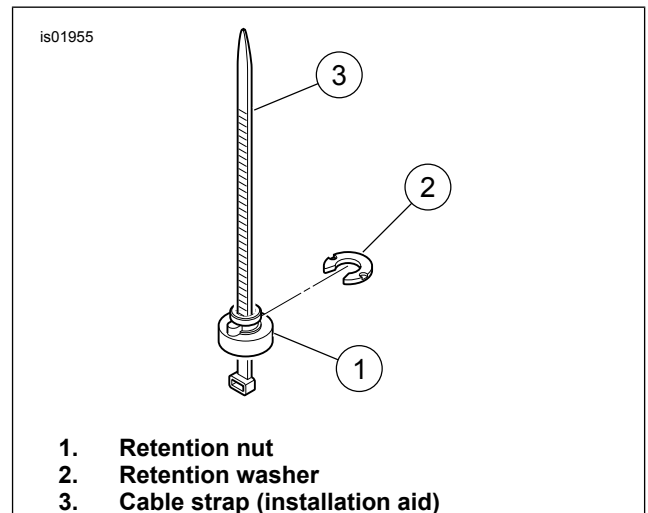

Figure 1. Retention Nut Installation

-J06349



Many Harley-Davidson® Parts & Accessories are made of plastics and metals which can be recycled. Please dispose of materials responsibly.

1 / 3

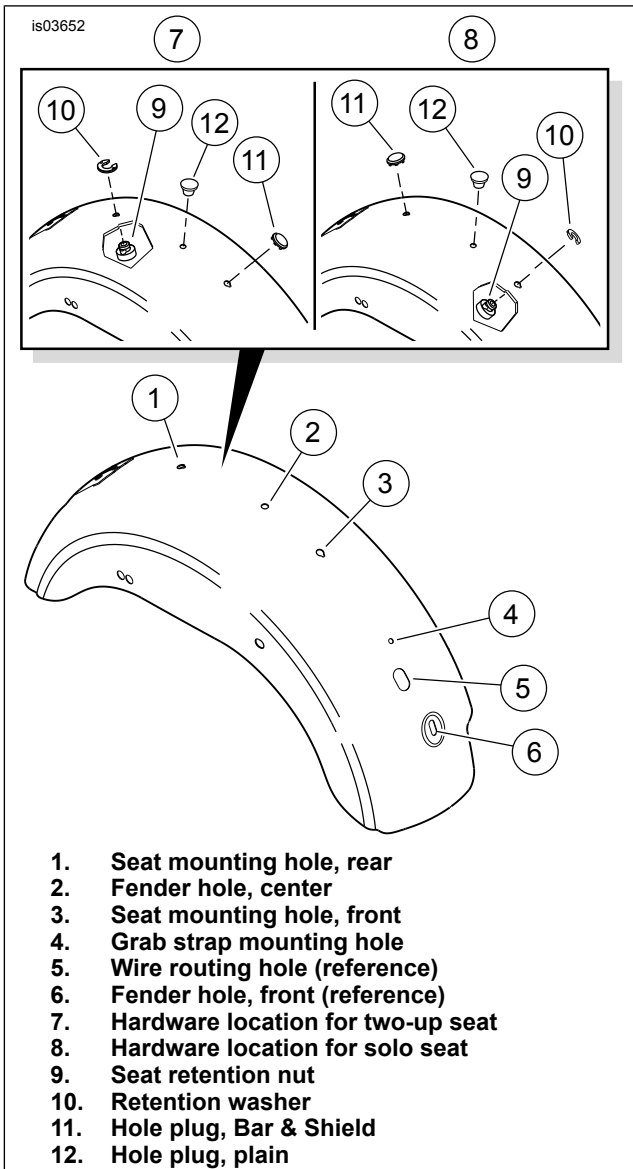

Figure 2. Fender Hole Identification and Hardware Locations

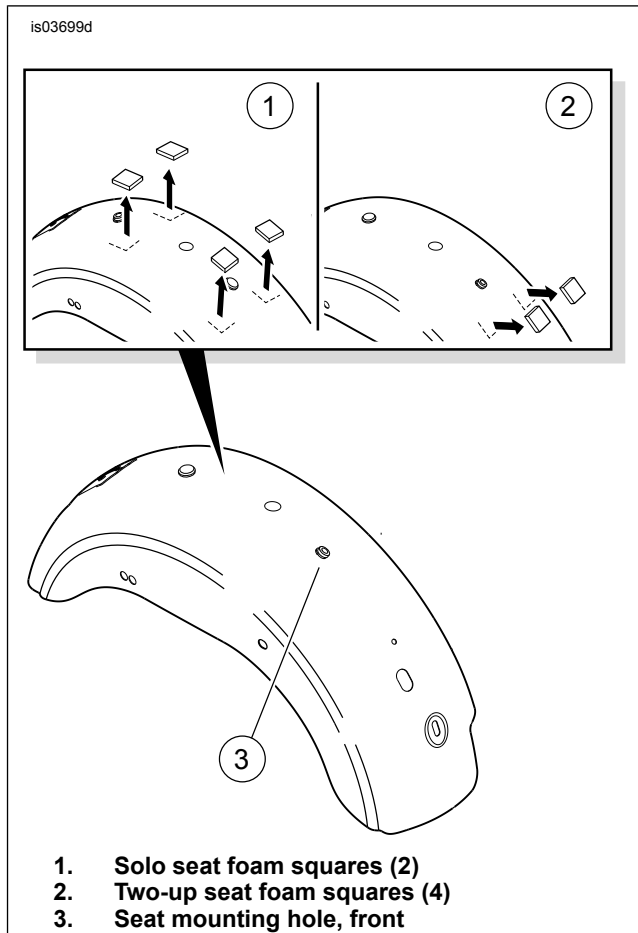

Figure 3. Foam Squares on Fender

## INSTALLATION

1. Insert the front tongue of seat into hole in the frame/fuel tank.
2. See Figure 4. Secure the seat to the fender with the knurled knob (2) and nylon washer (3) from the kit.
3. Complete seat installation. After installing seat, pull up on the seat to verify that it is secure.

### NOTE

Ambient temperature of **at least 60 °F (16 °C)** for proper adhesion of the emblem to the knob.

4. Remove the liner from the adhesive backing of the Bar & Shield emblem (4). Rotate the emblem for best appearance, and apply the emblem to the center recess on the knurled knob. Apply even pressure to the emblem for one minute for proper adhesion.

## SERVICE PARTS

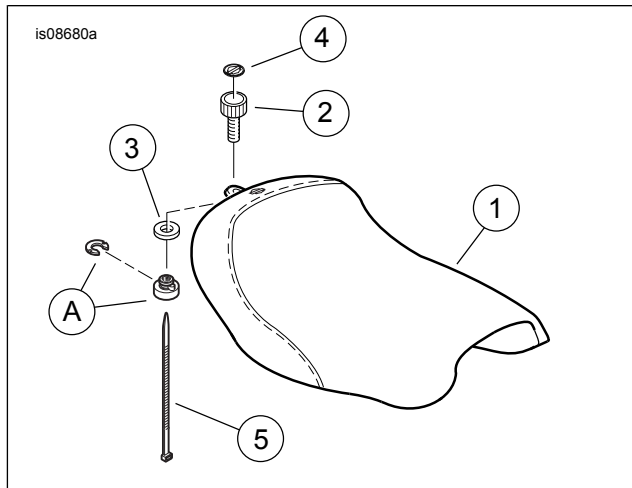

Figure 4. Service Parts: Dyna Solo Seat Kit

Table 1. Service Parts

Item	Description (Quantity)	Part Number
1	Seat	Not Sold Separately
2	Knurled knob, 1/4-20	51948-07
3	Washer, nylon	6441
4	Emblem, bar & shield	14628-96
5	Cable strap (installation aid)	10039
6	Leather dressing	Not Sold Separately
<b>Items mentioned in text.</b>		
A	Retension nut and washer	