



# INSTRUCTIONS

-J00596

REV. 2007-02-08

## VRSC ACCESSORY BACKREST PADS

### GENERAL

#### Kit Number

51569-01, 51583-01, 51589-05, 51599-05, 51645-06, 51782-07, 51783-07, 51982-08, 52748-02, 53762-06, 53763-06.

#### Models

For model fitment information, please see the P&A Retail Catalog or the Parts and Accessories section of [www.harley-davidson.com](http://www.harley-davidson.com) (English only).

#### Kit Contents

Table 1. Kit Contents

Item	Description (Qty)	Part Number
1	Backrest pad	Not Sold Separately
2	Screw (2)	4263M

### INSTALLATION

#### NOTE

*It is easiest to mount these backrest pads with the sissy bar upright kit already installed.*

1. Install the sissy bar upright according to the instructions included with that kit.
2. Hold backrest pad against upright with pad facing forward.
3. See Figure 1. Align two pad mounting holes in sissy bar upright with two threaded inserts in backrest pad.

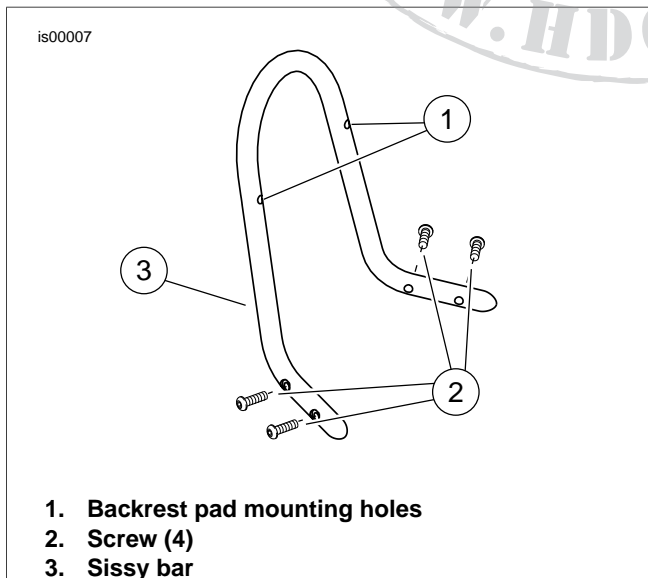

Figure 1. Sissy Bar and Screws

4. See Figure 2. Begin threading each of the two button head cap screws. Threading these screws may be a little difficult at first since the screw must break through plastic sheeting inside the backrest pad to reach the threaded insert. It may be necessary to use a 4 mm hex wrench, while holding the backrest pad tight against the upright to get the screws started.
5. Using a 4 mm hex wrench (allen wrench), tighten each screw a little at a time, alternating side-to-side. This is done to ensure the vinyl stretches evenly in the recessed channel that the upright bar is drawn into. Continue alternating side-to-side until both screws are secure.
6. Tighten both screws to 50-60 in-lbs (5.6-6.8 Nm).

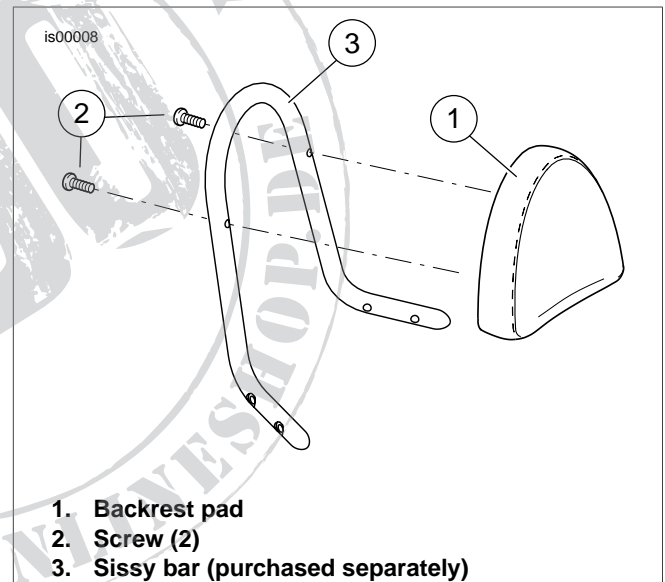

Figure 2. Generic Backrest Pad Assembly