



INSTRUCTIONS

-J04731

REV. 2008-11-13

RIDER BACKREST PAD

GENERAL

Kit Number

51564-09A, 51631-09A, 52530-09A, 52572-09A, 52583-09A, 52900-09A, 52914-09A

Models

For model fitment information, see the P&A Retail Catalog or the Parts and Accessories section of www.harley-davidson.com (English only).

Separate purchase and installation of additional parts or accessories may be required for proper installation of this kit on your model motorcycle. Please see the P&A Retail Catalog or the Parts and Accessories section of www.harley-davidson.com (English only) for a list of required parts or accessories for your model.

INSTALLATION

1. Install appropriate mounting bracket hardware (sold separately).
2. Hold slit between rider and passenger seat open. On rider backrest, compress backrest rods and spring. Insert rods into backrest mounting bracket.

BACKREST PAD ADJUSTMENT

1. Adjust fore/aft position of backrest pad. Use 3/16 inch hex wrench to adjust set screw that is accessible through eyelet opening on rear of pad. If possible, do not remove set screw because it is difficult to install.

SERVICE PARTS

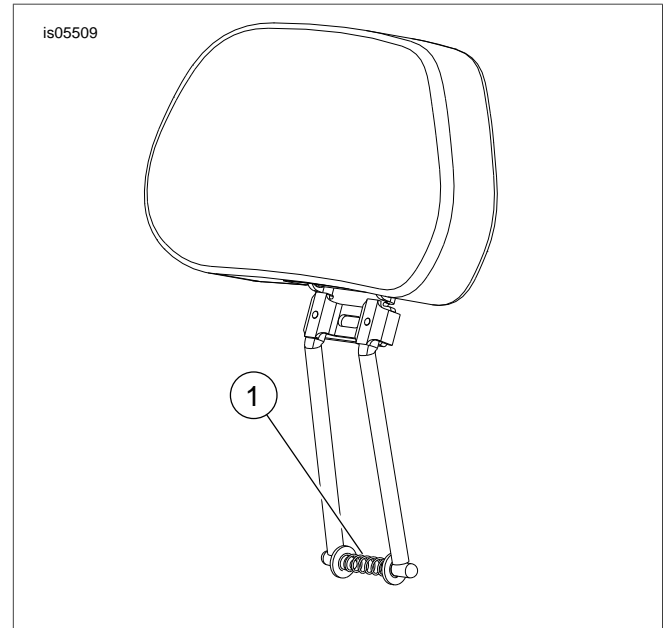

Figure 1. Service Parts: Rider Backrest Pad Kit

Table 1. Service Parts Table

Item	Description (Quantity)	Part Number
1	Spring	10406

