



INSTRUCTIONS

-J05067

REV. 2010-01-29

ELECTRA GLO LIGHTED PASSENGER FOOTBOARD INSERT KITS

GENERAL

Kit Numbers

51287-10, 51289-10, 51291-10, 51304-10

Models

For model fitment information, see the P&A retail catalog or the Parts and Accessories section of www.harley-davidson.com (English only).

NOTES

These footboard inserts fit traditional "D" shaped rider footboard pans only. They will not fit "Swept Wing", "Tapered", "Half-Moon" or "Old-Style" footboards.

The passenger Electra Glo™ footboards must be used with the rider footboards with the passenger wiring harness connecting to the rider wiring harness.

Electra Glo lighted footboard inserts are designed and intended for display use only. Some local regulations prohibit the use of colored lighting while the vehicle is operated on public streets and highways.

Check local regulations regarding vehicle operation with colored lighting.

WARNING

The rider's safety depends upon the correct installation of this kit. If the procedure is not within your capabilities or you do not have the correct tools, have a Harley-Davidson dealer perform the installation. Improper installation of this kit could result in death or serious injury. (00308a)

NOTE

This instruction sheet refers to service manual information. A service manual for this year/model motorcycle is available from a Harley-Davidson dealer.

Electrical Overload

NOTICE

It is possible to overload your motorcycle's charging system by adding too many electrical accessories. If your combined electrical accessories operating at any one time consume more electrical current than your vehicle's charging system can produce, the electrical consumption can discharge the battery and cause vehicle electrical system damage. See a Harley-Davidson dealer for advice about the amount of current consumed by additional electrical accessories, or for necessary wiring changes. (00211b)

WARNING

When installing any electrical accessory, be certain not to exceed the maximum amperage rating of the fuse or circuit breaker protecting the affected circuit being modified. Exceeding the maximum amperage can lead to electrical failures, which could result in death or serious injury. (00310a)

This Lighted Rider Footboard Insert Kit requires up to 80 mA additional current from the electrical system.

Kit Contents

See Figure 3 and Table 1.

PASSENGER FOOTBOARD REMOVAL

1. Refer to the owner's manual and follow the instructions to remove the seat. Retain all seat mounting hardware.
2. Apply liquid dishwashing soap to the rubber isolator beads protruding through the bottom of the footboard pan. With the operator footboard in the "up" position, use a screwdriver to work the rubber beads out through the top of the footboard.
3. Repeat Step 2 on the other side of the vehicle.
4. Remove both footboard pans according to service manual instructions.

INSTALLATION

Footboard Insert Installation

NOTE

The footboard inserts are side-specific. The footboard inserts install so that the top of the Bar & Shield logo is toward the front of the vehicle.

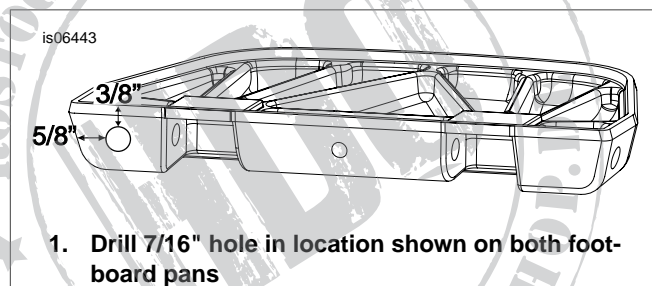

Figure 1. Drill Holes for Wire Harness in Footboard Pans

1. See Figure 1. Drill a 7/16 inch hole into the sidewall of both footboard pans as shown in Figure 2. Remove sharp edges and burrs. When installed, the right footboard pan will have the hole in the front and the left footboard pan will have the hole at the rear of the pan.

- Apply dishwashing soap to wire harness. Remove the grommet and feed wire through the hole.
- Slide the grommet up the wire harness and fit into hole.
- Install footboard according to service manual instructions.
- With the footboard in the "up" position, place the insert into position on the footboard pan, and hold it firmly in place.
- Apply liquid dishwashing soap to the rubber isolator beads on the **new** footboard insert.
- From the underside of the footboard, use a pliers to pull each rubber isolator bead into its mating hole in the footboard pan until the thick collar protrudes through the pan.
- Repeat Steps 2 through 7 on the other side of the vehicle.

- Allow sufficient wire length to allow the footboards to pivot freely through their entire range, then use cable straps (6) from the kit to tie the footboard insert harnesses to the back sides of the passenger footboard mounting brackets.
- Disconnect the accessory power harness from the right side rider footboard wiring harness.
- Connect the right side passenger "Y" harness male connector to the right side rider harness.
- Connect the left side passenger "Y" harness female connector to the accessory power harness connector. Connect passenger "Y" harness to the female connector from step 3.

NOTE

Make sure the harness is positioned to avoid moving parts, heat sources and chafe points.

- Use cable straps to secure the footboard insert wire harness to the frame tubes and vehicle harnesses along its entire length.

NOTES

These lighted footboards are designed and intended for display use only. Some local regulations prohibit the use of colored lighting while the vehicle is operated on public streets and highways.

Check local regulations regarding vehicle operation with colored lighting.

- Turn the **ignition key switch** to ACCESSORY, but do not start the motorcycle.

Check the operation of the footboard inserts. The footboards should turn on and off with actuation of the **accessory switch** on the inner fairing cap.

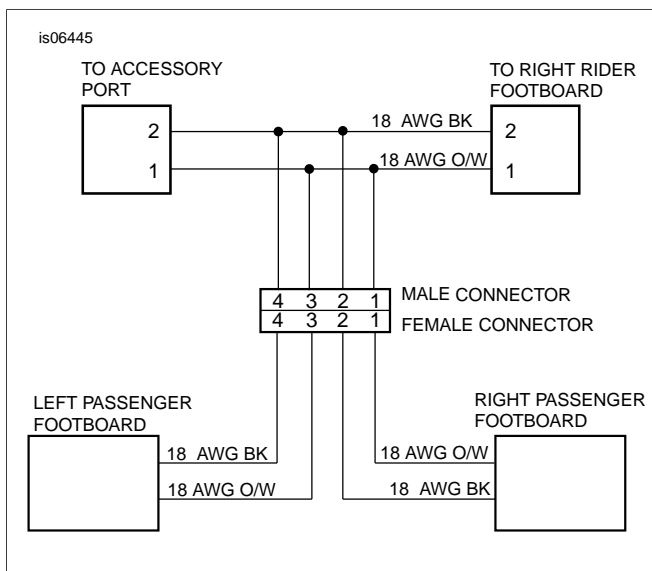

Figure 2. Passenger Footboard Leads Connected to "Y" Harness

Passenger Footboard Wire Routing

- See Figure 2, Figure 3 and Table 1 to make the wire connections. Apply the contents of the dielectric grease packet (4) to the footboard insert wiring harness and all harness connector terminals.
- Route harness leads the up the frame rails to the area under the seat.
- Left passenger footboard (2): Install orange/white wire with pin to female connector (5) in the number 3 cavity. Install black wire with pin to number 4 cavity.

WARNING

After installing seat, pull upward on seat to be sure it is locked in position. While riding, a loose seat can shift causing loss of control, which could result in death or serious injury. (00070b)

- Refer to the owner's manual, and follow instructions to install the seat.

NOTE

Avoid the contact of chrome surfaces with abrasive materials (stones, sand, etc.) as damage will result.

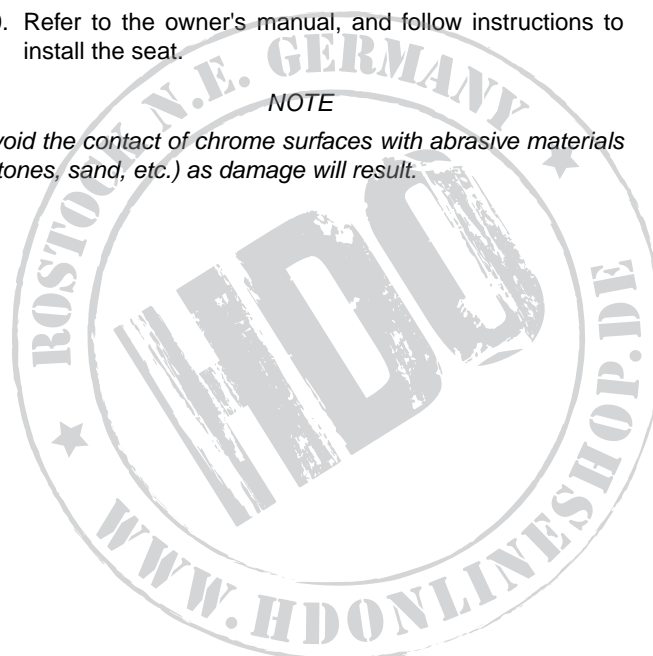

SERVICE PARTS

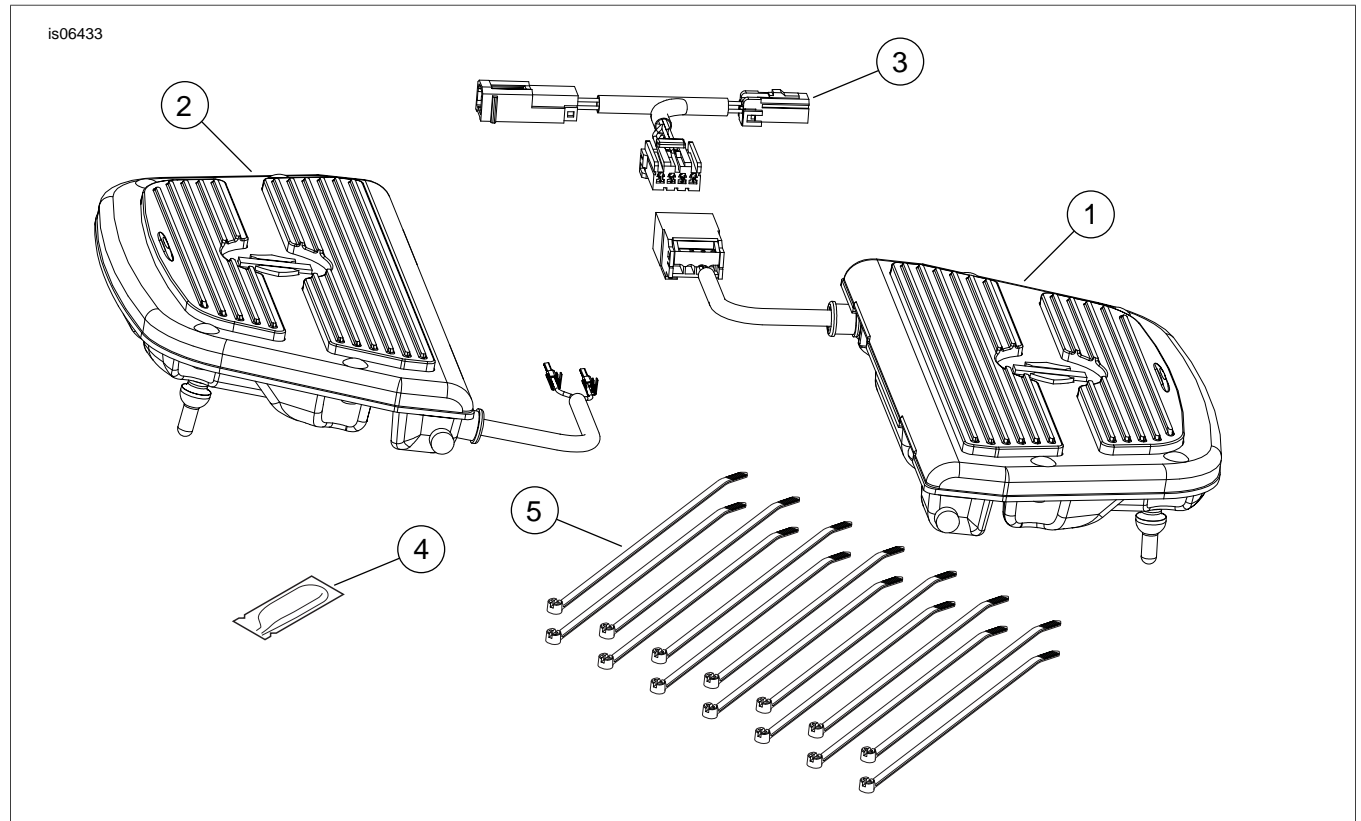

Figure 3. Service Parts: Electra Glo Lighted Passenger Footboard Insert

Table 1. Service Parts Table

Kit	Item	Description (Quantity)	Part Number
Kit 51287-10 Footboard Inserts, Red	1	Footboard assembly, right (Red), includes "Y" harness	50489-10
	2	Footboard assembly, left (Red)	51342-10
Kit 51289-10 Footboard Inserts, Amber	1	Footboard assembly, right (Amber), includes "Y" harness	50007-10
	2	Footboard assembly, left (Amber)	51370-10
Kit 51291-10 Footboard Inserts, Blue	1	Footboard assembly, right (Blue), includes "Y" harness	50010-10
	2	Footboard assembly, left (Blue)	51371-10
Kit 51304-10 Footboard Inserts, Purple	1	Footboard assembly, right (Purple), includes "Y" harness	50052-10
	2	Footboard assembly, left (Purple)	50237-10
Parts common to ALL kits	3	"Y" harness	Not sold separately
	4	Packet, dielectric grease	76001-04
	5	Cable strap (14)	10006