



INSTRUCTIONS

-J04380

REV. 2007-07-10

CUSTOM FOOTPEG KIT

GENERAL

Kit Number

50915-90T, 50916-90T

Models

For model fitment information, please see the P&A Retail Catalog or the Parts and Accessories section of www.harley-davidson.com (English only).

Kit Contents

See Figure 3 and Table 1.

INSTALLATION

1. Remove the hardware fastening the stock footpeg to the motorcycle footpeg support. Save the hardware for installation of new footpegs.
2. Remove the existing footpegs and spring washers. Note the orientation of, and save, the spring washers for installation.

NOTE

See Figure 2. When installing the footpeg support mount on the motorcycle footpeg support make sure the spring washer (1) is positioned inside of the footpeg support with the square edge toward the inside of the support.

3. Install the new footpeg mount in reverse order of stock footpeg mount removal. Place a spring, along with the mount end of the footpeg, inside the slots of the footpeg supports.

NOTE

Secure each footpeg mount an spring washer with the screw and locknut removed earlier. Tighten the locknuts to 19 ft-lbs (26 Nm).

WARNING

Footrests must fold up and toward rear of motorcycle if struck. Failure to set footrests to fold up and back could result in death or serious injury. (00366a)

4. See Figure 1. For each footpeg, position the footpeg as desired, then righten the adjusting screw (1) to 21 ft-lbs (29 Nm).

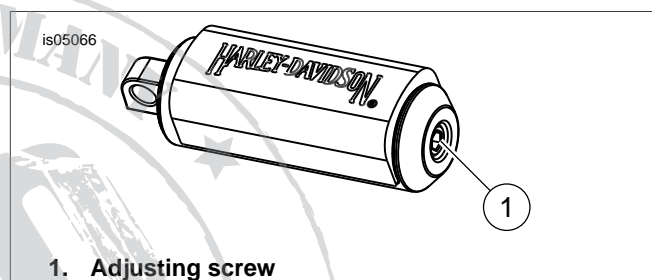

Figure 1. Footpeg Adjusting Screw

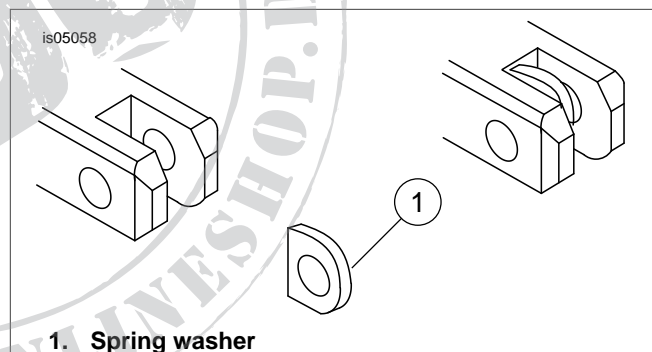

Figure 2. Footpeg Spring Washer Installation

SERVICE PARTS

is05067

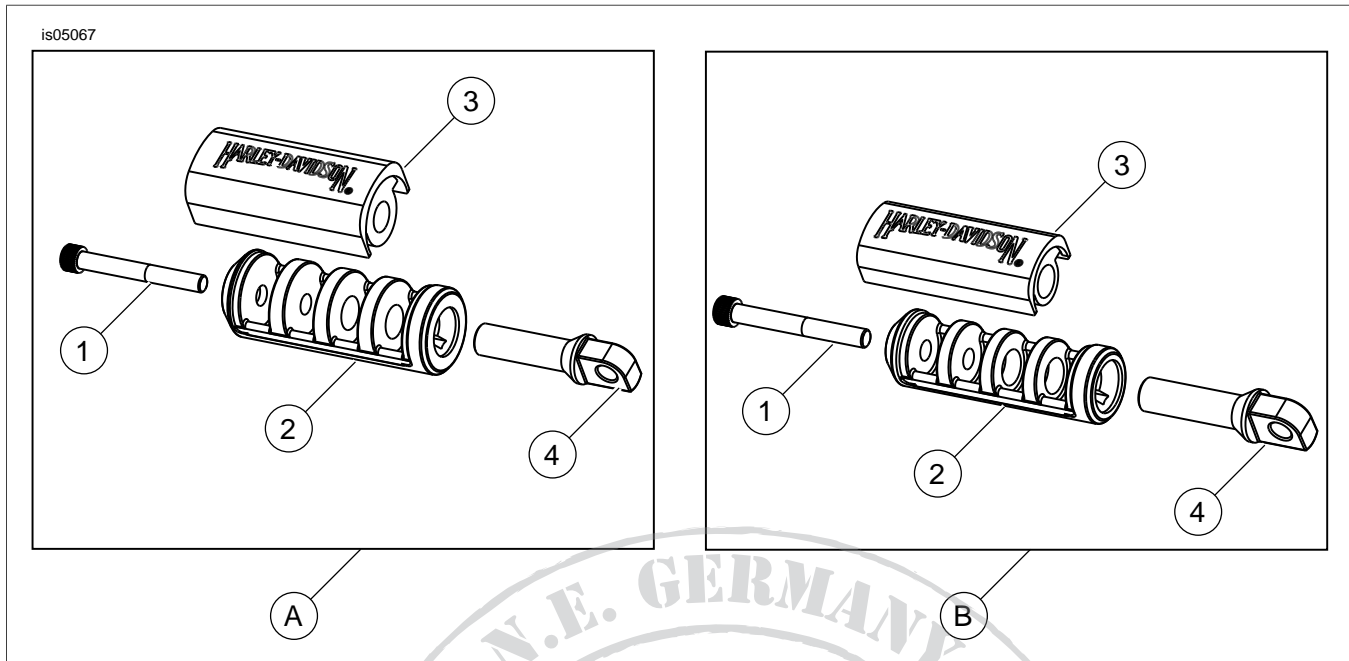

Figure 3. Service Parts: Custom Shifter Peg Kit

Table 1. Service Parts Table

Item	Description (Quantity)	Part Number
A - Kit 50915-90T		
1	Screw (2)	Not Sold Separately
2	Body (2)	Not Sold Separately
3	Kit, cushion	50917-90T
4	Mount (2)	Not Sold Separately
B - Kit 50916-90T		
1	Screw (2)	Not Sold Separately
2	Body (2)	Not Sold Separately
3	Kit, cushion	50918-90T
4	Mount (2)	Not Sold Separately