



INSTRUCTIONS

-J04551

REV. 2009-06-03

FRAME MOUNT HIGHWAY PEG KIT

GENERAL

Kit Number

50855-09 (chrome), 50865-09 (black)

Models

For model fitment information, see the P&A Retail Catalog or the Parts and Accessories section of www.harley-davidson.com (English only).

Additional Parts Required

Separate purchase and installation of footpegs is required. See the P&A Retail Catalog or the Parts and Accessories section of www.harley-davidson.com (English only) for a list of required parts or accessories for your model.

WARNING

The rider's safety depends upon the correct installation of this kit. If the procedure is not within your capabilities or you do not have the correct tools, have a Harley-Davidson dealer perform the installation. Improper installation of this kit could result in death or serious injury. (00308a)

Kit Contents

See Figure 3 and Table 1.

INSTALLATION

1. See Figure 1. Assemble the arms to the center frame bracket using bolts (1), lock washers (2) and flat washers (7) (not shown). Screw in bolts finger-tight.
2. Place the center flange of the arm assembly **behind** the cross member just below the steering head and insert a bolt (3) through the cross-member and arm assembly bracket.
3. Install a lockwasher (4) and a nut (5) to the arm assembly bolt and tighten to 15 ft-lbs (20.3 Nm).
4. Install the bracket clamps (6) to wrap around the back of the down tubes and attach to the center arm bracket using the bolts (3), lockwashers (4) and nuts (5). Tighten bolts to 15 ft-lbs (20.3 Nm).
5. See Figure 2. Install the clevis (3) to the arm bracket using bolt (1) and washer (2). Screw in bolt finger-tight.
6. Position the square end of the spring washer (4) to the inside of the clevis and the rounded edge facing out from the end of the clevis. Hold the spring washer in place and position the footpeg (purchased separately) into the clevis and install the clevis pin (5) into the clevis and secure the pin with a lock washer (6) and retaining ring (7).

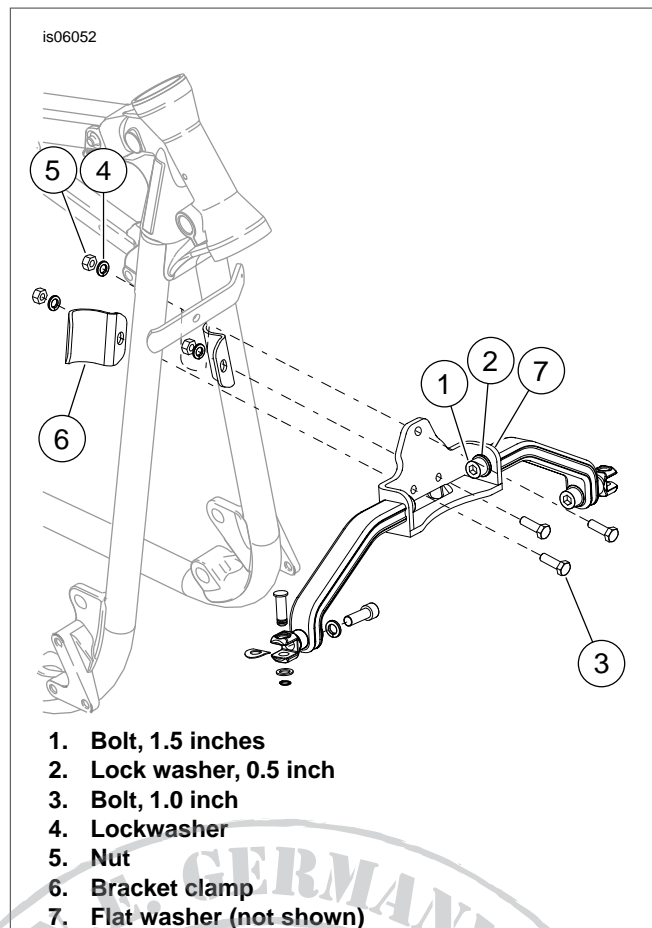

Figure 1. Install Mounting Bracket

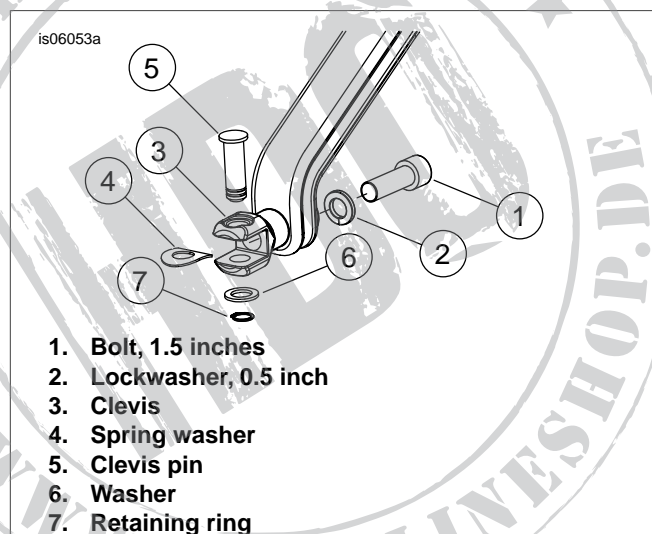

Figure 2. Install Footpegs

7. Repeat steps 6 and 7 for the opposite footpeg.

WARNING

Footrests must fold up and toward rear of motorcycle if struck. Failure to set footrests to fold up and back could result in death or serious injury. (00366a)

WARNING

Position footpegs so rider can operate foot controls without interference. Failure to have full access to foot controls can cause loss of control, which could result in death or serious injury. (00313a)

8. Rotate the footpegs to a comfortable position that allows the footpegs to fold up and back at an angle. Tighten the clevis screws to 75 ft-lbs (101.7 Nm).

9. After all adjustments have been made, tighten the arm bolts at the center frame bracket to 75 ft-lbs (101.7 Nm).

SERVICE PARTS

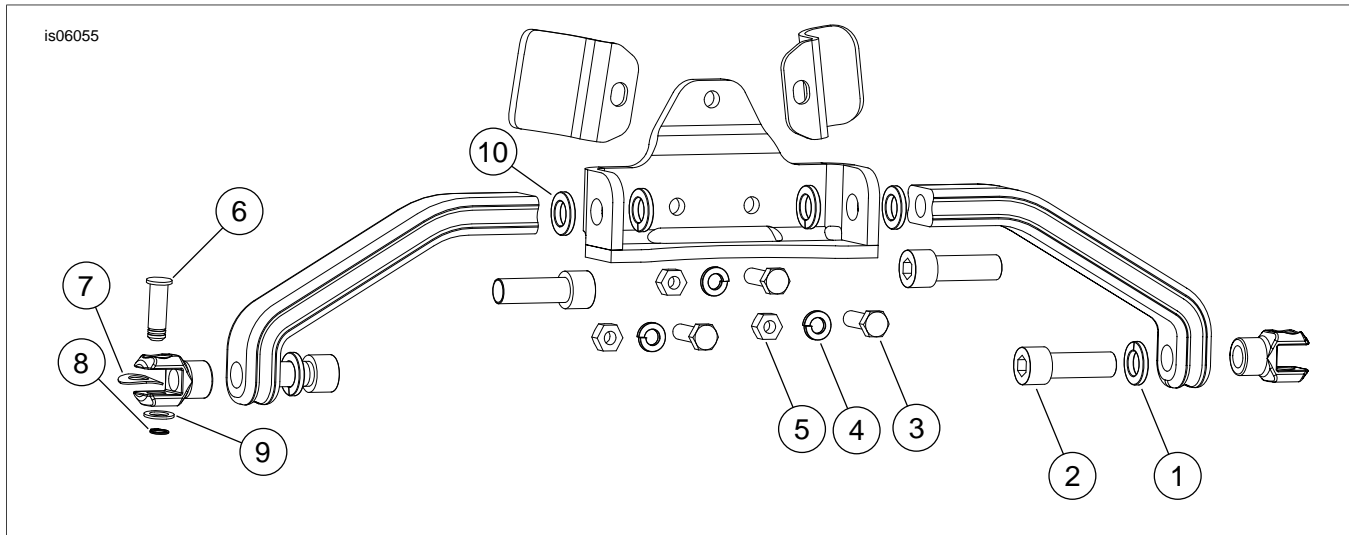

Figure 3. Service Parts: Frame Mount Highway Peg Kits

Table 1. Service Parts Table

Item	Description (Quantity)	Part Number
1	Lockwasher (4)	7068
2	Bolt, 1/2-20 x 1.5 inch (4)	3549A
3	Bolt, 5/16-18 x 1.0 inch (3)	4017
4	Lockwasher (4)	7041
5	Nut (3)	7748W
6	Clevis pin (2)	42680-01
7	Spring washer (2)	50912-72
8	Retaining ring (2)	11304
9	Washer (2)	6379W
10	Washer (2)	6012

