



INSTRUCTIONS

-J02838

REV. 2006-02-02

OFFSET HIGHWAY FOOTPEG MOUNTING KIT

GENERAL

Kit Number

50906-03, 50908-03, 50827-07, 50828-07

Models

These kits are designed for installation on Harley-Davidson models equipped with 1-1/4 inch diameter front engine guards.

Kits 50906-03 and 50827-07 have a long arm.

Kits 50908-03 and 50828-07 have a short arm.

Additional Parts Required

These kits require installing a set of male-mount style footpegs. A variety of footpegs are sold separately and available from your Harley-Davidson dealer.

NOTE

A Service Manual for your model motorcycle is available from a Harley-Davidson Dealer.

Kit Contents

See Figure 2 and Table 1.

INSTALLATION

⚠ WARNING

Position footpegs so rider can operate foot controls without interference. Failure to have full access to foot controls can cause loss of control, which could result in death or serious injury. (00313a)

⚠ WARNING

Mount the footpegs so they will not strike the ground during cornering. Footpegs striking the ground during cornering can cause loss of control, resulting in death or serious injury. (00458b)

1. Determine what height on the engine guard you prefer for the final mounting of the footpeg mounts. Mark location, if desired.
2. See Figure 1. Obtain the clamp assembly (1) from kit. Position the clamp halves around the engine guard at the desired height and install with hinge pin head facing upward. Place the flatwasher between the ears of the clamp halves. Hold parts in position.
3. See Figure 2. Obtain the clamp adapter (10) and install with "cogged" face of the adapter facing the footpeg extension (14).

4. Obtain the lockwasher (13), screw (7) and one of the offset extension arms (14) (long or short depending on kit number) from kit. Install the lockwasher, to screw. Install the screw (7) through clamp halves and washer (5) and thread into extension arm (14). Position arm as desired but do not tighten completely at this time.

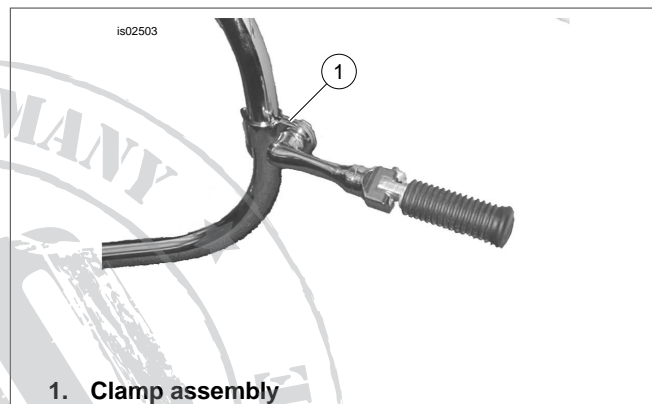

Figure 1. Footpeg Mount Installed (Long Mount Shown with Footpeg Installed)

5. Obtain clevis and extension assembly (6) from kit. Position clevis such that footpeg will pivot upward and towards the rear of the motorcycle. NOTE: It may be necessary to loosen the screw holding the extension arm and rotate extension arm to obtain this position. Tighten 5/16-18 x 2-3/4 inch screw (9) to 29 ft-lbs (39.0 Nm).
6. Obtain the footpeg (sold separately), D-spring washer (12) and 3/8 x 1 inch screw (8) from kit. Install the D-spring washer so it is positioned inside the clevis with the square "D" edge towards the inside of the mount. Hold the washer in place and slide the footpeg into position. Install the screw (8) and tighten to 19 ft-lbs (26 Nm). Note: The footpeg will be a tight fit if the D-spring washer is installed correctly.
7. Repeat Steps 1 through 6 for the opposite side. Position the footpeg assemblies so they are at equal heights and symmetrical. Securely tighten each assembly until it cannot be rotated on the the guard with reasonable foot pressure, but do not exceed 55 ft-lbs (81 Nm) on item 7.

⚠ WARNING

If footpeg mounting location increases motorcycle width, maintain clearance between motorcycle and surrounding persons or objects. Failure to maintain clearance could result in death or serious injury. (00314a)

SERVICE PARTS

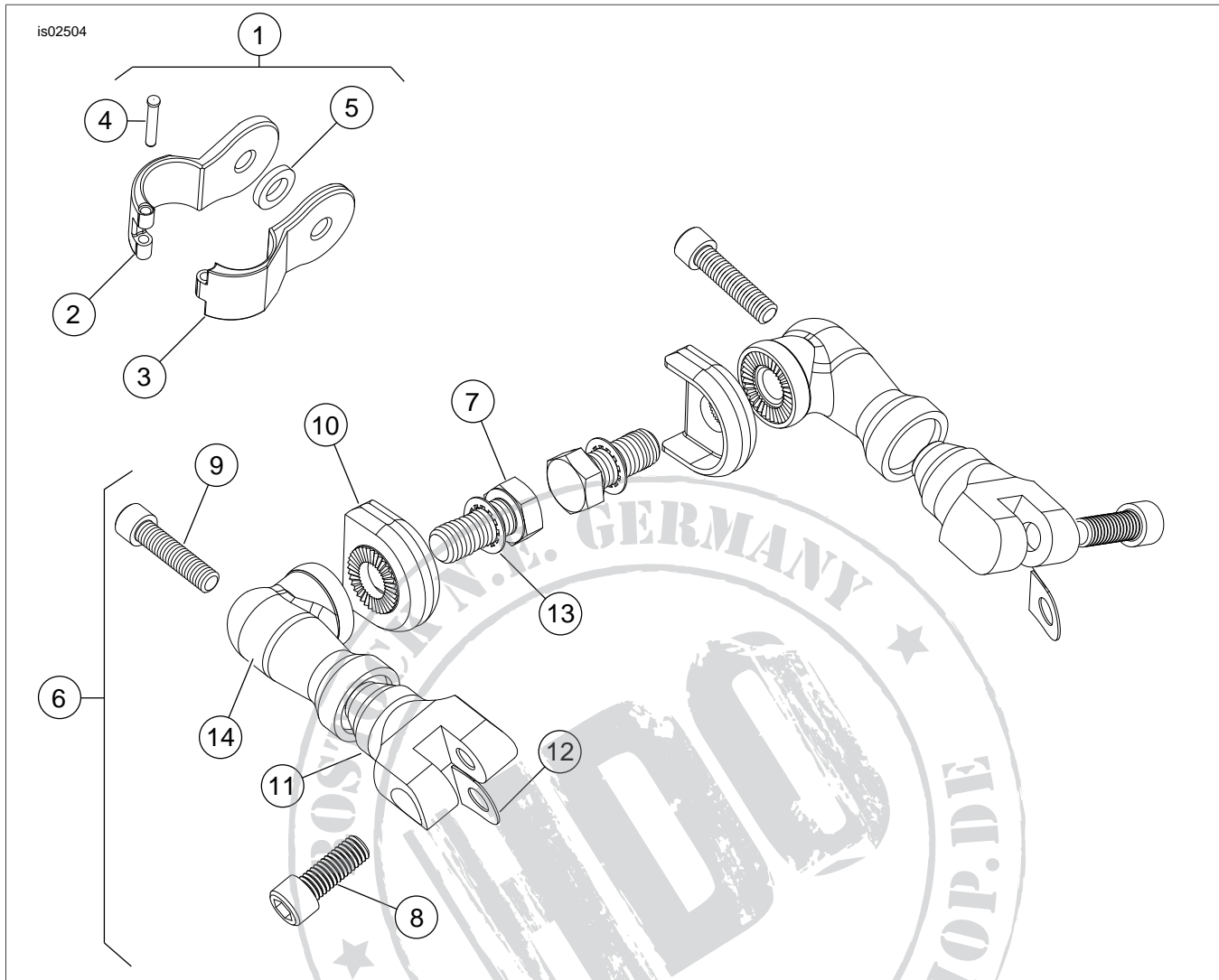

Figure 2. Service Parts: Offset Highway Footpeg Mounting Kits

Table 1. Service Parts Table

Item	Description (Quantity)	Part Number	Item	Description (Quantity)	Part Number
Kit number 50906-03 (long)			Kit number 50908-03 (short)		
1	Assembly, mounting clamp (2)	50928-03	1	Assembly, mounting clamp (2)	50928-03
2	• Clamp (female) (2)	Not sold separately	2	• Clamp (female) (2)	Not sold separately
3	• Clamp (male) (2)	Not sold separately	3	• Clamp (male) (2)	Not sold separately
4	• Pin, hinge (2)	Not sold separately	4	• Pin, hinge (2)	Not sold separately
5	• Flatwasher, 9/16 inch (2)	6091	5	• Flatwasher, 9/16 inch (2)	6091
6	Assembly, peg extension (long) (2)	50907-03	6	Assembly, peg extension (short) (2)	50909-03

Table 1. Service Parts Table

Item	Description (Quantity)	Part Number		Item	Description (Quantity)	Part Number
7	• Screw, hex 1/2 x 1-1/8 inch (2)	4063		7	• Screw, hex 1/2 x 1-1/8 inch (2)	4063
8	• Screw, 3/8 x 1 inch (2)	4087		8	• Screw, 3/8 x 1 inch (2)	4087
9	• Screw, 5/16 x 2-3/4 inch (2)	4114		9	• Screw, 5/16 x 2-3/4 inch (2)	4089
10	• Adapter, clamp, chrome (2)	Not sold separately		10	• Adapter, clamp, chrome (2)	Not sold separately
11	• Clevis, male mount chrome (2)	Not sold separately		11	• Clevis, male mount chrome (2)	Not sold separately
12	• D-washer, 3/8 inch (2)	50912-72		12	• D-washer, 3/8 inch (2)	50912-72
13	• Lockwasher, internal tooth (2)	7133		13	• Lockwasher, internal tooth (2)	7133
14	• Extension, footpeg (2) (not shown)	Not sold separately		14	• Extension, footpeg (2) (not shown)	Not sold separately
Kit number 50827-07 (long)				Kit number 50828-07 (short)		
1	Assembly, mounting clamp (2)	50831-07		1	Assembly, mounting clamp (2)	50831-07
2	• Clamp, mounting (female) (2)	Not sold separately		2	• Clamp, mounting (female) (2)	Not sold separately
3	• Clamp, mounting (male) (2)	Not sold separately		3	• Clamp, mounting (male) (2)	Not sold separately
4	• Pin, hinge (2)	Not sold separately		4	• Pin, hinge (2)	Not sold separately
5	• Flatwasher, 9/16 inch (2)	6091		5	• Flatwasher, 9/16 inch (2)	6091
6	Assembly, peg extension (long) (2)	50907-03		6	Assembly, peg extension (short) (2)	50909-03
7	• Screw, hex 1/2 x 1-1/8 inch (2)	4063		7	• Screw, hex 1/2 x 1-1/8 inch (2)	4063
8	• Screw, 3/8 x 1 inch (2)	4087		8	• Screw, 3/8 x 1 inch (2)	4087
9	• Screw, 5/16 x 2-3/4 inch (2)	4114		9	• Screw, 5/16 x 2-3/4 inch (2)	4114
10	• Adapter, clamp, chrome (2)	Not sold separately		10	• Adapter, clamp, chrome (2)	Not sold separately
11	• Clevis, male mount chrome (2)	Not sold separately		11	• Clevis, male mount chrome (2)	Not sold separately
12	• D-washer, 3/8 inch (2)	50912-72		12	• D-washer, 3/8 inch (2)	50912-72
13	• Lockwasher, internal tooth (2)	7133		13	• Lockwasher, internal tooth (2)	7133
14	• Extension, footpeg (2) (not shown)	Not sold separately		14	• Extension, footpeg (2) (not shown)	Not sold separately
NOTE: Long arm is shown in illustration. Assembly procedure is the same for Short arm.						