



INSTRUCTIONS

-J03164

REV. 2006-03-16

SWEPT WING CHROME PASSENGER FOOTBOARD KIT

GENERAL

Kit Number

50716-04

Models

For the most up-to-date model fitment information, please see the product label or www.harley-davidson.com.

Additional Parts Required

Installing this kit also requires installing new passenger footboard inserts, sold separately. Refer to the latest Harley-Davidson Genuine Motor Accessories and Parts Catalog or ask any Harley-Davidson dealer about matching operator footboards and the selection of operator and passenger inserts that are available for these models. These items can be easily installed at the same time as this kit.

Kit Contents

See Figure 1 and Table 1.

INSTALLATION

1. **If passenger footboards are not currently installed:** Proceed to Step 4.

If passenger footboards are currently installed: See Tilt the footboard (1) to the "up" position. Remove the underside chrome footboard covers if so equipped.

From the bottom of the footboard, use a small flat-blade screwdriver to push the rubber beads on the pad up through the holes in the footboard pan. Remove the pad.

2. Using a brass drift and rubber mallet, tap one pivot pin (B) out of the pivot hole into the center pocket of the footboard pan, remove the pin and set it aside. Repeat for the second pin.

3. Remove the footboard from the support bracket (E).
4. Place the detent spring (D) into the hole in the support bracket, and rest the steel ball (C) on top of the spring if not already in place.
5. Position the footboard onto the support, in the down position, being careful not to unseat the ball.
6. Align the pivot pin holes, and install the pivot pins from the outboard side. Using a brass drift and rubber mallet, tap the pins inward until centered in the lugs of the support bracket (E).
Check to ensure that the ball (C) remains seated in the detent on the underside of the footboard pan.
7. Place the footboard bottom assembly into position on the support, and install the retaining pins from the outboard sides. Using a brass drift and rubber mallet, tap the pins until centered in the lugs of the support.
8. Apply liquid dishwashing soap to the dowel pins and pivot pin holes on the footboard insert.
9. Place the footboard insert into position on the footboard pan. Firmly grasp the hinge side of the footboard and insert with both hands. Insert the dowel pins in the footboard pan into the mating holes in the footboard insert.
10. Tilt the footboard to the "up" position. Tighten the setscrew (3) to secure the insert in place.
11. Repeat the above steps for the remaining footboard.

NOTE

Avoid the contact of chrome surfaces with abrasive materials (stones, sand, etc.) as damage will result.

SERVICE PARTS

is03208

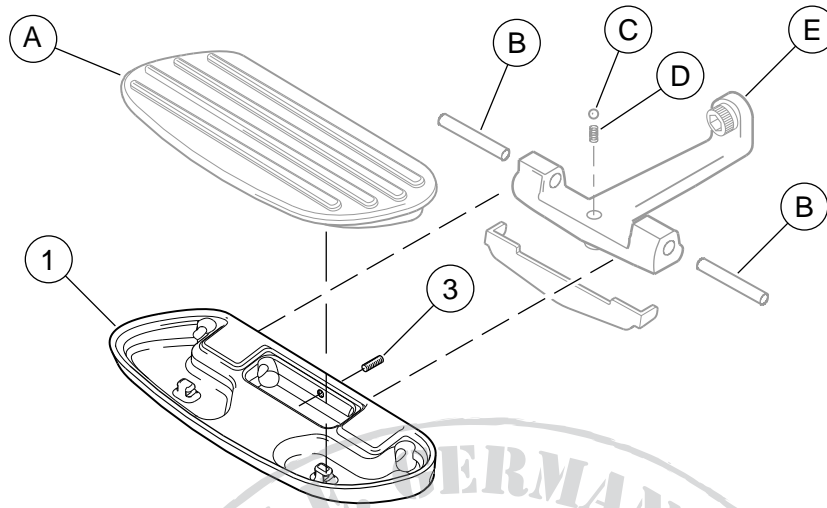

Figure 1. Service Parts: Swept-Wing Passenger Footboard Kit

Table 1. Service Parts Table

Item	Description (Quantity)	Part Number
1	Footboard, passenger (right)	50722-04
2	Footboard, passenger (left) (not shown)	50721-04
3	Set screw	3341
Items mentioned in text, but not included in kit:		
A	Passenger footboard insert	
B	Pivot pin	
C	Ball	
D	Spring	
E	Footboard support bracket	