



# INSTRUCTIONS

-J5426

REV. 2011-04-04

## SLIPSTREAM BRAKE PEDAL PAD KIT

### GENERAL

#### Kit Number

50600040

See Figure 1 below for a list of kit contents.

#### Models

For model fitment information, see the P&A Retail Catalog or the Parts and Accessories section of [www.harley-davidson.com](http://www.harley-davidson.com) (English only).

#### Additional Parts Required

Separate purchase and installation of additional parts or accessories may be required for proper installation of this kit on your model motorcycle. See the P&A Retail Catalog or the Parts and Accessories section of [www.harley-davidson.com](http://www.harley-davidson.com) (English only) for a list of required parts or accessories for your model.

### WARNING

The rider's safety depends upon the correct installation of this kit. Use the appropriate service manual procedures. If the procedure is not within your capabilities or you do not have the correct tools, have a Harley-Davidson dealer perform the installation. Improper installation of this kit could result in death or serious injury. (00333a)

#### NOTE

This instruction sheet references service manual information. A service manual for your model motorcycle is required for this installation and is available from a Harley-Davidson dealer.

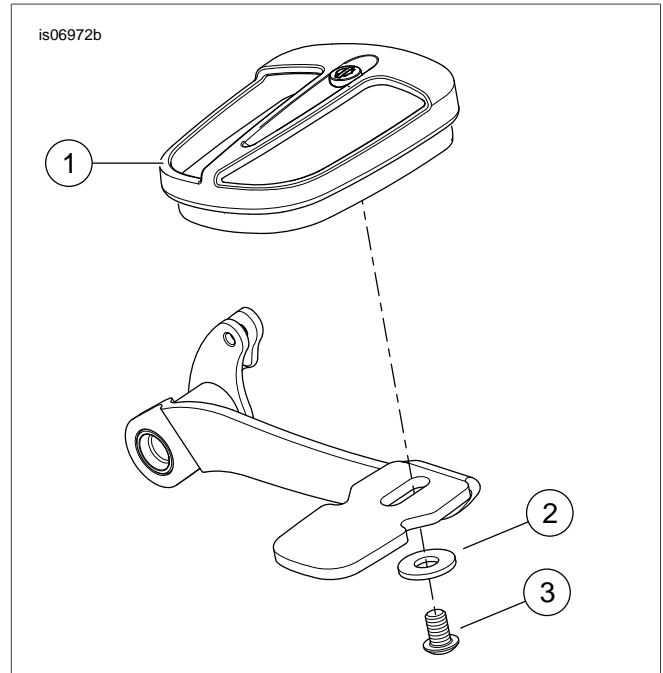

Figure 1. Slipstream Brake Pedal Kit Contents

Table 1. Service Parts

Item	Description (Quantity)	Part Number
2	Brake pedal assembly	Not Sold Separately
3	Washer	6333
4	Screw, button head	3340

### INSTALLATION

1. Remove and discard the previously installed brake pedal cover from the foot brake lever.
2. Align the brake pedal assembly (2) over the lever as shown. Insert the button fastener (1) into the brake pedal assembly, assemble the washer (3), screw (4) and thread the screw through the hole in the brake lever and into the back of the pad.
3. Tighten the screw to 10 ft-lbs (13.5 Nm).

### WARNING

After repairing the brake system, test brakes at low speed. If brakes are not operating properly, testing at high speeds can cause loss of control, which could result in death or serious injury. (00289a)