



INSTRUCTIONS

-J03939

REV. 2011-04-29

BRAKE PEDAL PAD KIT (SMALL)

GENERAL

Kit Number

42650-08, 50600037

Models

For model fitment information, see the P&A Retail Catalog or the Parts and Accessories section of www.harley-davidson.com (English only).

Kit Contents

See Figure 1 and Table 1.

NOTE

A service manual is available at your Harley-Davidson dealer.

INSTALLATION

1. Remove the previously installed brake pedal cover from the foot brake lever.
2. See Figure 1. Obtain the new chrome pedal pad cover (1), pad tread (2), screw (4) and washer (3) from the kit. Insert the pad tread into the pedal pad cover and align the assembly over the foot brake lever (A).
3. Insert the screw with washer through the hole in the brake lever through the pad tread, then thread into the chrome pad cover.
4. Tighten the hex socket head screw to 69-84 in-lbs (8-10 Nm).

WARNING

After repairing the brake system, test brakes at low speed. If brakes are not operating properly, testing at high speeds can cause loss of control, which could result in death or serious injury. (00289a)

SERVICE PARTS

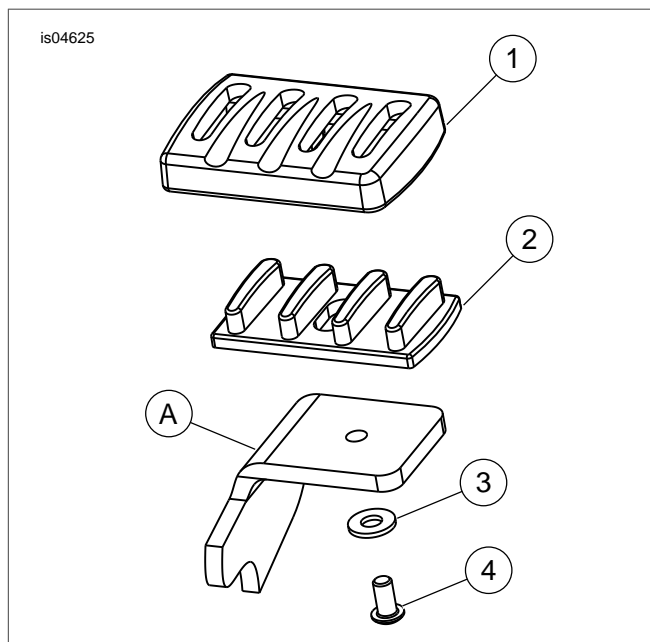

Figure 1. Service Parts: Brake Pedal Pad Kit (Stealth Kit Shown)

Table 1. Service Parts: Brake Pedal Pad Kit

Item	Description (Quantity)	Part Number
1	Pad cover, chrome	Not Sold Separately
2	Tread, pad	Not Sold Separately
3	Washer, #10 (Kit No. 42650-08)	6703
	Washer, plain (Kit No. 50600037)	6716
4	Screw, button head (Kit No. 42650-08)	3063
	Screw, button head (Kit No. 50600037)	3026
Items mentioned in text, but not included in kit.		
A	Foot brake lever	