



INSTRUCTIONS

-J04519

REV. 2008-07-18

X2 FOOTPEG KIT

GENERAL

Kit Number

50472-08

Models

This footpeg kit is designed for installation on all Harley-Davidson models equipped with "male mount" style footpeg supports.

Kit Contents

See Figure 2 and Table 1.

WARNING

The rider's safety depends upon the correct installation of this kit. If the procedure is not within your capabilities or you do not have the correct tools, have a Harley-Davidson dealer perform the installation. Improper installation of this kit could result in death or serious injury. (00308a)

INSTALLATION

1. Remove the locknuts and screws that hold the existing footpegs in place. If the motorcycle is equipped with a pin and retaining ring, remove them and retain for future use. Save all hardware for installation of the new footpegs.
2. Remove the existing footpegs and the spring washers. Save the spring washers for installation.

NOTE

See Figure 1. When performing the next step, verify that the spring washer is positioned inside of the footpeg support with the square edge (2) towards the inside of the support.

3. See Figure 1. Install the new footpegs in the same manner as the old footpegs were installed. Insert a spring washer (1) and the mount end of the footpeg inside the slots (3) of the footpeg supports.
4. Secure each footpeg and spring washer with the screw and locknut or pin and retaining ring removed earlier. Tighten the locknuts to 19 ft-lb (26 Nm).

WARNING

Footrests must fold up and toward rear of motorcycle if struck. Failure to set footrests to fold up and back could result in death or serious injury. (00366a)

5. See Figure 2. For each footpeg, insert the adjusting screw (5) in the footpeg support mount (4) recessed hole and

begin to thread the screw. Rotate the footpeg to a comfortable position, verifying that the footpeg will fold up and back, then tighten the adjusting screw to 21 ft-lb (29 Nm).

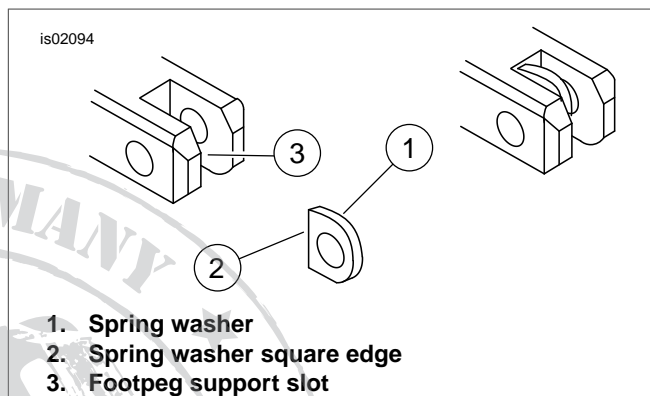

Figure 1. Footpeg Spring Washer Installation

SERVICE PARTS

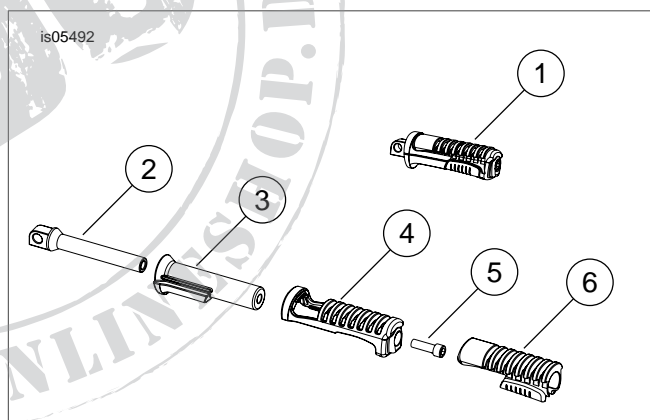

Figure 2. Service Parts: X2 Footpeg Kit

Table 1. Service Parts Table

Item	Description (Quantity)	Part Number
1	Footpeg assembly (2) (includes items 2 through 6)	50473-08
2	Footpeg support mount	50351-03
3	Footpeg bottom	Not Sold Separately
4	Footpeg top	Not Sold Separately
5	Screw, socket head	3156
6	Footpeg tread	Not Sold Separately