



INSTRUCTIONS

-J02574

REV. 2007-05-15

FLAMES (MALE-MOUNT) FOOTPEG KIT

GENERAL

Kit Number

50312-03

Models

This kit is designed for installation on all Harley-Davidson models equipped with "male-mount" style footpeg supports.

Kit Contents

Table 1. Kit Contents

Description (Quantity)	Part Number
Assembly, footpeg (left)	50316-03
Assembly, footpeg (right)	50313-03

INSTALLATION

1. See Figure 1. Remove the locknuts and screws that hold the existing footpegs in place. Save all hardware for installation of the new footpegs.
2. Remove the existing footpegs along with the spring washers. Save the spring washers for later installation.

NOTE

When performing Step 3, make sure the spring washer is positioned inside of the footpeg support with the square edge towards the inside of the support as shown in Figure 2.

3. Install the new footpegs in the same manner as the old footpegs were installed. Place a spring washer, along with the mount end of the footpeg, inside the slots of the footpeg supports.
4. Secure each footpeg and spring washer with the screw and locknut removed earlier. Tighten the locknuts to 19 ft-lbs (26 Nm).
5. Refer to Figure 1. For each footpeg, loosen the adjusting screw in the recessed hole until the footpeg rotates. Position the footpeg as desired, then tighten the adjusting screw to 21 ft-lbs (29 Nm).

WARNING

Footrests must fold up and toward rear of motorcycle if struck. Failure to set footrests to fold up and back could result in death or serious injury. (00366a)

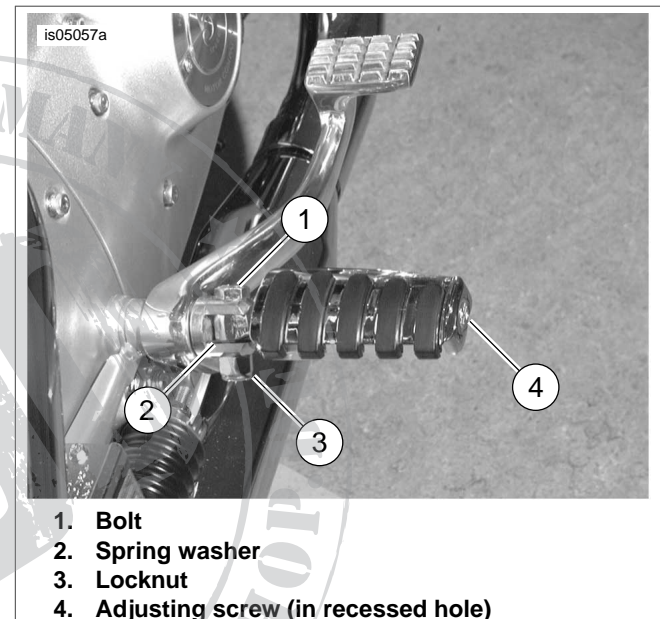

Figure 1. Installing the Footpeg

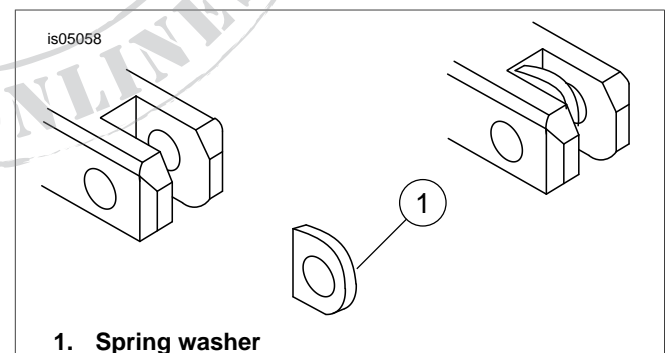

Figure 2. Footpeg Spring Washer Installation