



# INSTRUCTIONS

-J03792

REV. 2005-05-18

## PASSENGER FOOTPEG MOUNTING KIT

### GENERAL

#### Kit Number

50210-06

#### Models

This kit fits all 2006 and later Dyna model motorcycles with original equipment solo seat and no footpegs. It is required when installing a 2-up seat on these models.

This kit is also a direct replacement for the standard equipment passenger footpeg (footrest) mounting brackets on 2006 and later Dyna models with original equipment 2-up seats.

#### Additional Parts Required

Proper installation of this kit requires the installation of a passenger footpeg on each mounting bracket. See a Harley-Davidson dealer. Refer to the appropriate Parts Catalog for original equipment footrests, or see the current Harley-Davidson Genuine Motor Accessories and Parts catalog for a selection of operator and passenger footpegs.

### WARNING

The rider's safety depends upon the correct installation of this kit. Use the appropriate service manual procedures. If the procedure is not within your capabilities or you do not have the correct tools, have a Harley-Davidson dealer perform the installation. Improper installation of this kit could result in death or serious injury. (00333a)

#### NOTE

This instruction sheet references Service Manual information. A Service Manual for your model motorcycle is required for this installation and is available from a Harley-Davidson Dealer.

Special tools are required for the installation of this kit. We recommend that this kit be installed by a factory-trained technician at a Harley-Davidson dealer.

#### Kit Contents

See Figure 5 and Table 1.

### INSTALLATION

#### Left Side

1. Block the motorcycle under the frame so the rear wheel is off the ground.
2. See Figure 1. Remove the three self-tapping screws (2), and remove the debris deflector (1) from the vehicle.

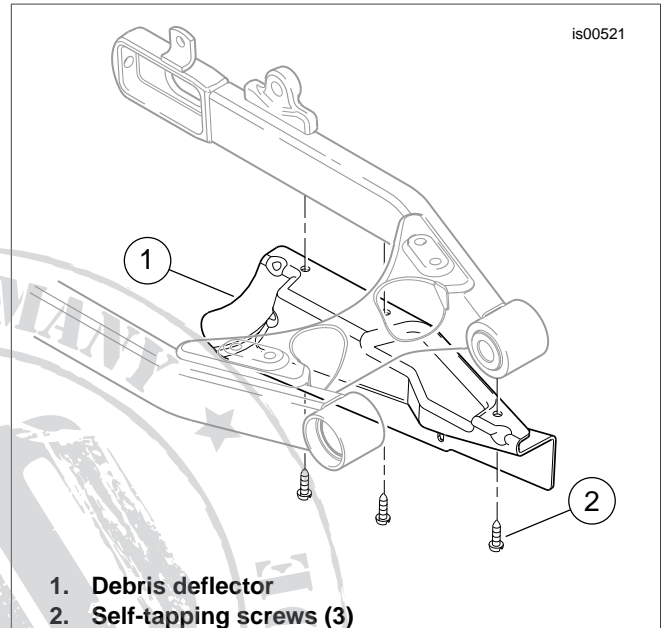

Figure 1. Debris Deflector Removal

3. See Figure 2. Remove the spring clip (1) from the left side of the rear axle. Loosen, but do not remove, the rear axle nut (2).
4. Turn the axle adjusters (3) on each side of the rear wheel counterclockwise about the same amount to move the rear wheel forward and allow slack in the drive belt.

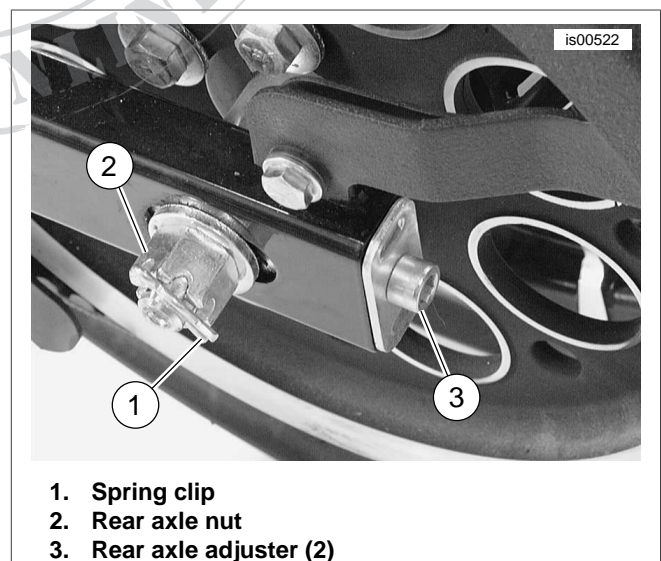

Figure 2. Rear Axle Nut and Adjusters

### NOTE

When removing the belt guard, make sure the belt guard does not contact the fender or the fender paint will be scratched.

5. See Figure 3. Remove and retain the front (1) and rear (2, 3) upper belt guard fasteners, and carefully remove the upper belt guard from the vehicle.

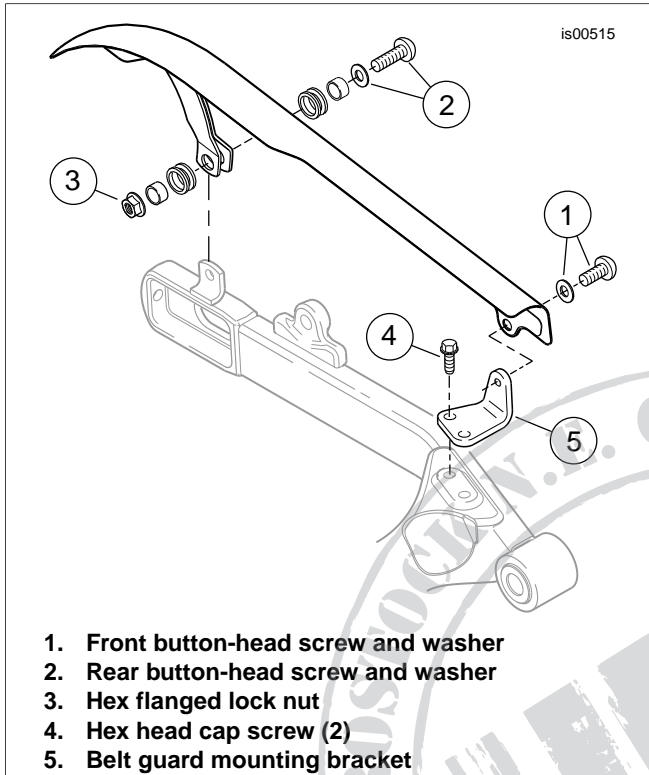

Figure 3. Upper Belt Guard Removal

6. Remove the two hex head cap screws (4) that attach the belt guard mounting bracket (5) to the rear fork. The bracket and screws can be discarded.
7. See Figure 5. Obtain the left-side footpeg support (2) and two self-tapping screws (3) from the kit. Install the support to the mounting location as shown, and torque the screws to 25-35 ft-lbs (34-47 Nm).
8. Re-install the upper belt guard with the fasteners removed earlier. Tighten the screws to 10-15 ft-lbs (13.5-20.3 Nm).
9. Re-install the debris deflector with the three screws removed earlier. Tighten the screws to 40-60 **in-lbs** (4.5-6.8 Nm).

### Right Side

10. Remove and discard the two plastic hole plugs (B) from the rear fork (A).

11. Obtain the right-side footpeg support (1) and two self-tapping screws (3) from the kit. Install the support to the mounting location as shown, and torque the screws to 25-35 ft-lbs (34-47 Nm).

### Footpegs

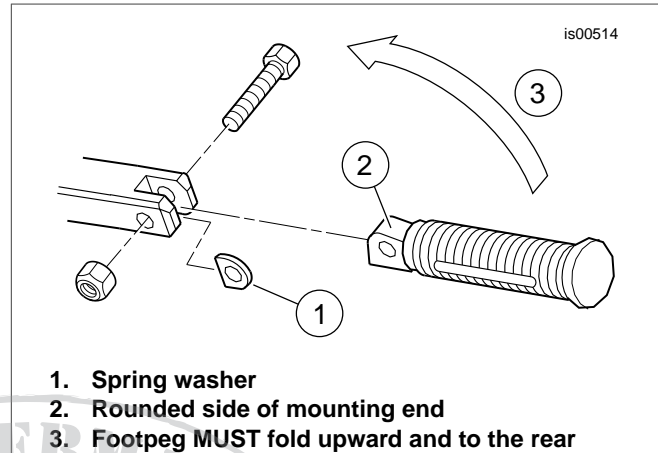

Figure 4. Proper Footpeg Installation

### NOTES

See Figure 4. The spring washer (1) goes between the jaws of the footpeg support bracket along with the mounting end of the footpeg.

Footpegs must be installed in the bracket with the rounded side (2) of the mounting end inboard. When footpegs are properly installed, footpegs will fold upward (3) at a 45° angle toward the rear of the motorcycle.

### WARNING

**Footrests must fold up and toward rear of motorcycle if struck. Failure to set footrests to fold up and back could result in death or serious injury. (00366a)**

12. See Figure 5. Install a passenger footpeg (purchased separately) on each footpeg support as shown, using a hex head cap screw (4), spring washer (5) and lock nut (6) from the kit.

### BELT ADJUSTMENT AND VEHICLE ALIGNMENT

Refer to REAR BELT DEFLECTION in the Service Manual, and follow the procedures given to inspect and adjust rear belt deflection.

See the VEHICLE ALIGNMENT section in the Service Manual to properly align the vehicle.

## SERVICE PARTS

is00513

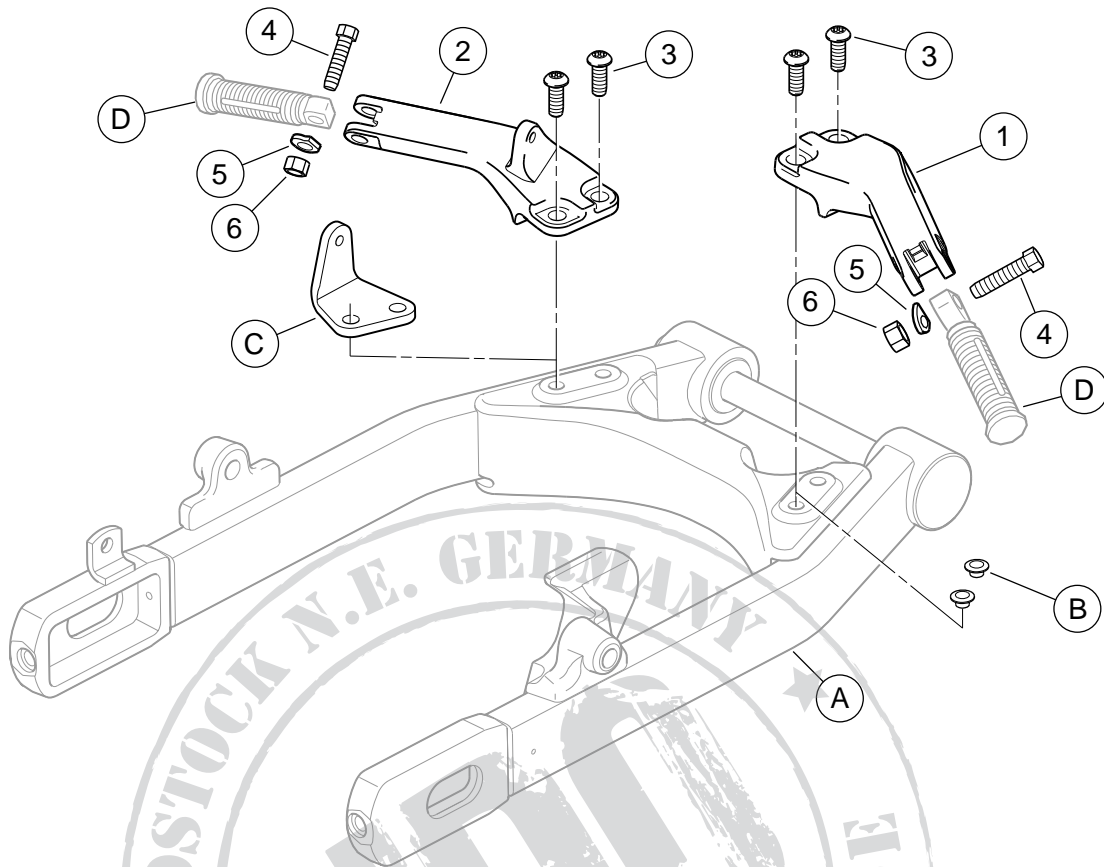

Figure 5. Service Parts, Passenger Footpeg Mounting Kit

Table 1. Service Parts Table

Item	Description (Quantity)	Part Number
1	Support, passenger footpeg (right side)	49224-06
2	Support, passenger footpeg (left side)	49230-06
3	Screw, button head, self-tapping, 3/8-16 x 1 in. (4)	4059
4	Cap screw, hex head, 3/8-16 x 1-1/2 in. (2)	4721
5	Spring washer (2)	50912-72
6	Hex lock nut, 3/8-16 (2)	7778
<b>Items mentioned in text, but not included in kit:</b>		
A	Rear fork	
B	Hole plug (2)	
C	Belt guard mounting bracket	
D	Passenger footpeg (2)	