



INSTRUCTIONS

-J00192

REV. 2006-06-09

CHROME PASSENGER FOOTBOARD COVERS

GENERAL

Kit Number

50193-96, 50194-96, 50782-91, 50246-00, 50836-07

Models

These kits fit 1987-later Touring, 1986-later FL Softail®, and 2006-later Dyna™ models equipped with traditional D-shaped Aluminum Passenger Footboards.

Kit Contents

Table 1. Service Parts

Item	Description (Quantity)	Part Number
1	Cover, passenger footboard (2)	Not sold separately
2	Screw, self tapping (4)	874

INSTALLATION

1. **For all 1992 and Earlier model vehicles:** See Figure 1. Remove passenger footboard assembly, including footboard support (1), from mounting stud on motorcycle. Depending on type of footboard support, this will require either removal of self-locking nut (2) and bolt (3), or removal of bolt (3) and lock washer (8) from footboard support split hub.

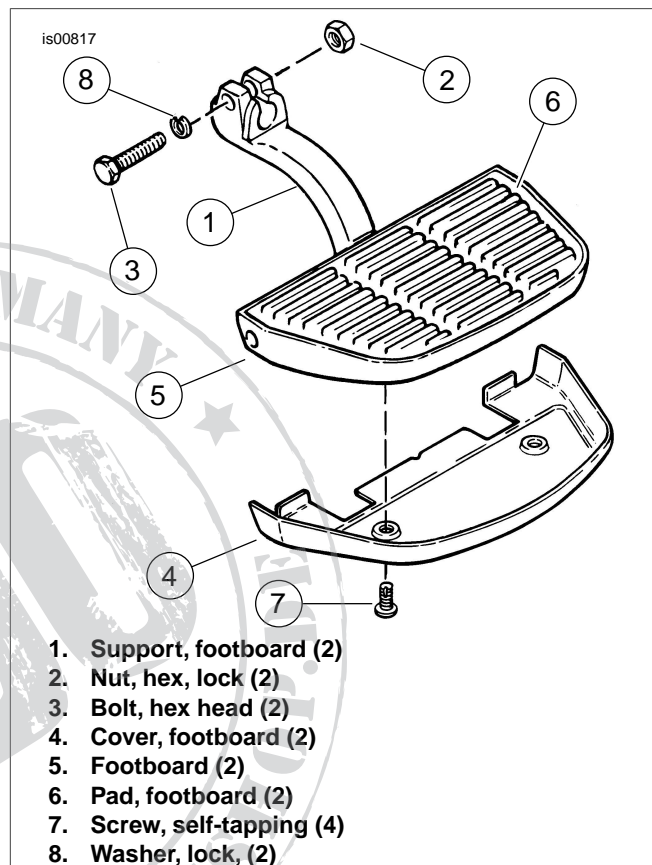

Figure 1. Passenger Footboard and Cover Assembly - 1992 and Earlier Model Vehicles

For all 1993 and Later model vehicles: See Figure 2. Remove passenger footboard assembly, including footboard support (1), from mounting stud on motorcycle. This will require removing the 3/8 in. Allen screw (2) and lockwasher (3) from footboard support.

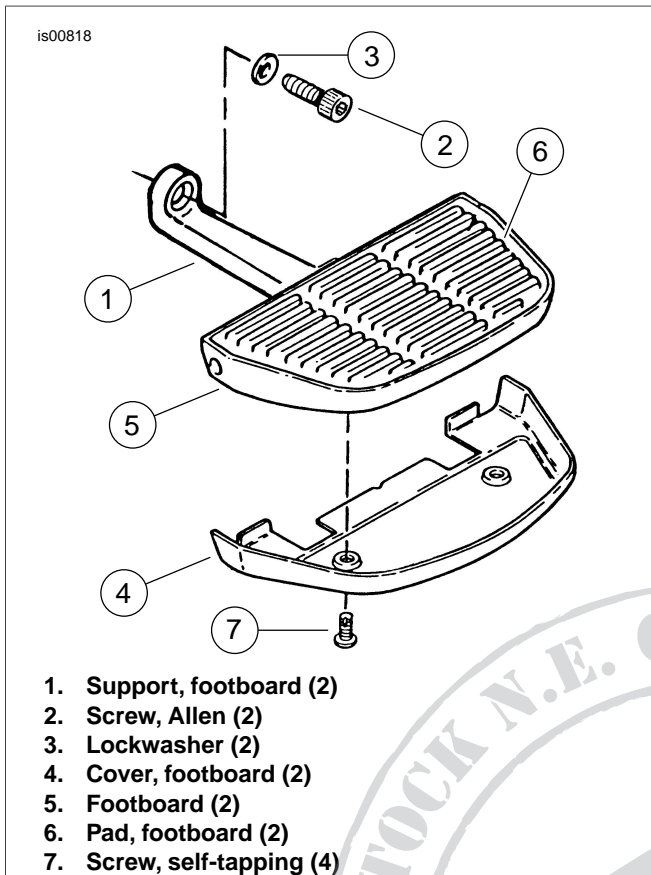

Figure 2. Passenger Footboard and Cover Assembly - 1993 and Later Model Vehicles

2. **For all model vehicles:** See Figure 1 or Figure 2. Position cover (4) from kit onto underside of footboard (5). Mark location of the two mounting holes of cover onto underside of footboard. Remove cover from footboard. Use a center punch to make a small indentation in exact center of each marked-off position on footboard; this will help to prevent the drill bit from "walking" during the following drilling procedure.

CAUTION

Always wear proper eye protection when drilling. Flying debris could cause serious eye injury. (00402c)

NOTE

When drilling cover mounting holes in footboard (5), take care not to exceed a drilling depth of 1/2 in. (13 mm) to avoid drilling through footboard pad (6).

3. Properly secure footboard (5) in preparation for drilling holes into its underside. Using a 5/32 in. Diameter drill bit, drill a hole into footboard (5) at each center punch point. Be careful to avoid drilling too deeply, which could damage footboard pad (6); however, holes must be deep enough to allow self-tapping screws (7) from kit to be installed without "bottoming" in holes. Use a drill stop tool to control drilling depth (not to exceed 1/2 in. (13 mm) in this case).

4. See Figure 3. If present, remove small diameter long tip of rubber bumpers that protrudes from aluminum footboard casting with knife or cutting pliers.

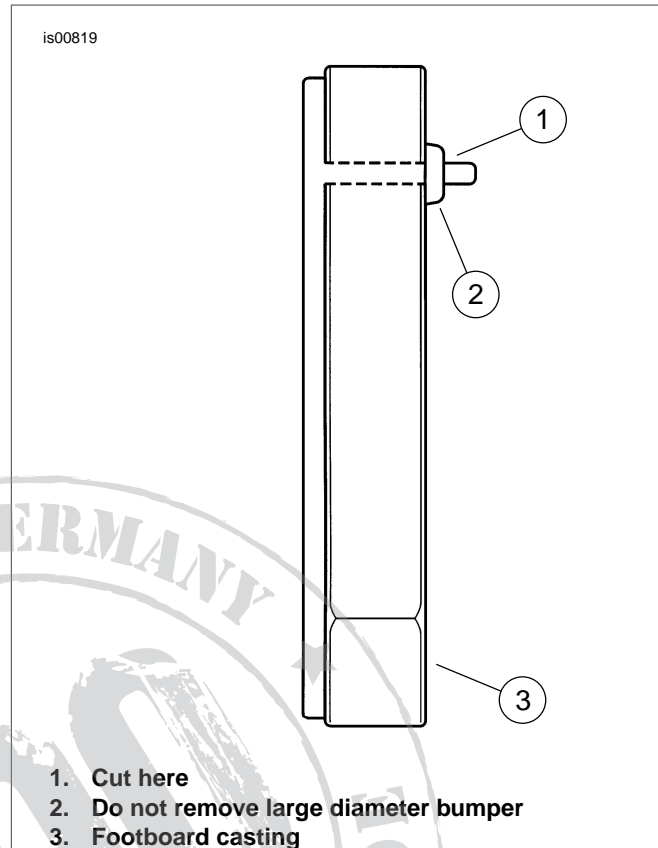

1. Cut here
2. Do not remove large diameter bumper
3. Footboard casting

Figure 3. Removing Tip From Rubber Bumper

5. Apply lightweight oil to threads of two self-tapping screws (7). Install screws partway into the two drilled holes in footboard (5); this will start to form the threads in the aluminum material. Remove screws (7), cleaning out any loose material from holes.
6. Install cover (4) onto footboard (5). Secure with the two self-tapping screws (7), fully seating each screw into its mounting hole.
7. **For all 1992 and Earlier model vehicles:** Install footboard and cover assembly in its original position onto mounting stud, so that bolt hole, in split hub of footboard support (1), aligns with machined groove in stud.
For all 1993 and Later model vehicles: Install footboard and cover assembly in its original position onto mounting stud, matching bolt holes of footboard support (1) and stud.
8. Install footboard support mounting fasteners, which had been removed in Step 1. For 1992 and Earlier model vehicles, tighten fasteners to 10 ft-lbs (13.5 Nm). For 1993 and Later model vehicles, tighten fasteners to 30 ft-lbs (40.7 Nm).
9. Repeat above steps for opposite side passenger footboard cover.