



INSTRUCTIONS

-J04530

REV. 2010-11-18

FOOTPEGS WITH WEAR TIP

GENERAL

Kit Number

50695-08, 50039-10, 50500025, 50500030, 50500035

Models

For model fitment information, see the P&A Retail Catalog or the Parts and Accessories section of www.harley-davidson.com (English only).

Additional Parts Required

Loctite® 243 Threadlocker and Sealant - Blue (Part No. 99642-97) to install replacement wear tips.

⚠ WARNING

The rider's safety depends upon the correct installation of this kit. Use the appropriate service manual procedures. If the procedure is not within your capabilities or you do not have the correct tools, have a Harley-Davidson dealer perform the installation. Improper installation of this kit could result in death or serious injury. (00333a)

NOTE

This instruction sheet references service manual information. A service manual for your model motorcycle is required for this installation and is available from a Harley-Davidson Dealer.

Kit Contents

See Figure 3 and Table 1.

REMOVAL

1. See Figure 1. Remove retaining ring (5), spring washer (4) and clevis pin (3) to remove footpeg (1).

INSTALLATION

⚠ WARNING

Footrests must fold up and toward rear of motorcycle if struck. Failure to set footrests to fold up and back could result in death or serious injury. (00366a)

1. See Figure 2. Install footpeg to clevis and insert spring washer (flat side toward clevis), clevis pin and retaining ring. Wear tip must point down.
2. If the footpeg is secured by a screw and nut, refer to the appropriate service manual for torque specifications.

Wear Tip Replacement

1. Remove existing wear tip from footpeg.
2. Apply 2 or 3 drops of Loctite 243 Threadlocker and Sealant (Blue) to the threads of the new wear tip and install to the footpeg.

3. For Kits 50039-10, 50695-08: Tighten wear tip to 6-9 ft-lbs (8.1-12.2 Nm).

For Kits 50500025, 50500030, 50500035: Tighten wear tip to 14-16 ft-lbs (19.0-21.7 Nm).

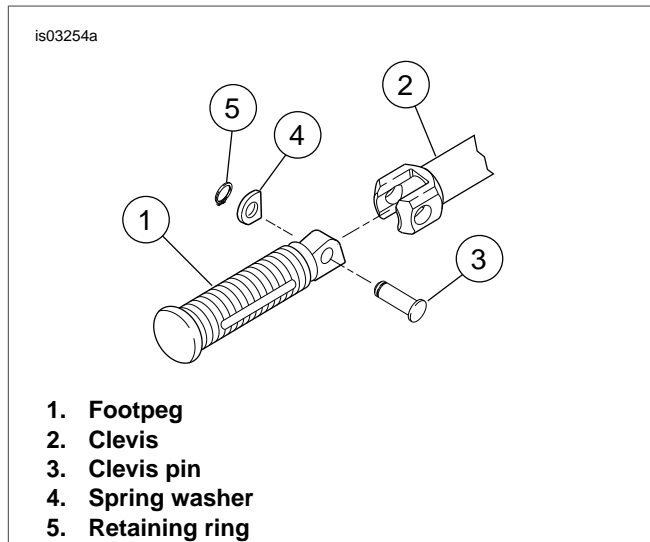

Figure 1. Footpeg Remove/Install (generic footpeg shown)



Figure 2. Correct installation (generic footpeg and wear tip)

SERVICE PARTS

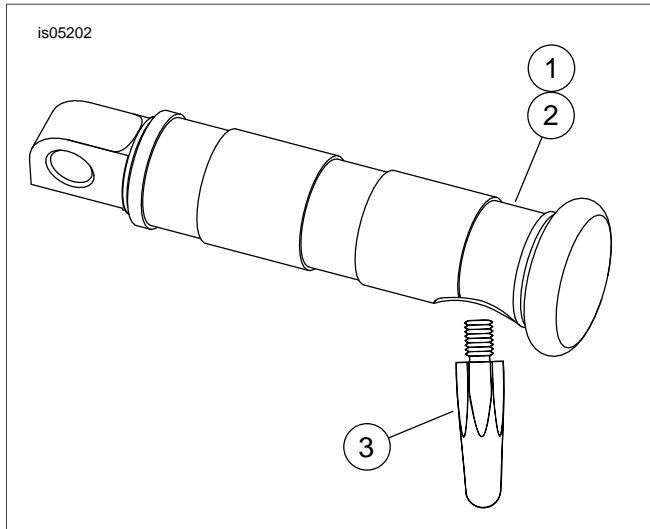

Figure 3. Service Parts: Footpegs and Wear Tip (Kit 50695-08 shown)

Table 1. Service Parts

Item	Description (Quantity)	Part Number
1	Footpeg assembly, billet, right side	Not Sold Separately
2	Footpeg assembly, billet, left side	Not Sold Separately
3	Wear tip (Buell part number) (Kit 50695-08 only)	C0255.02A8
	Wear tip (Kit 50039-10 only)	50891-10
	Wear tip (Kit 50500025 only)	50500022
	Wear tip (Kit 50500030 only)	50500023
	Wear tip (Kit 50500035 only)	50500024

