



# INSTRUCTIONS

-J02643

2014-08-04

## ENGINE GUARD KITS

### GENERAL

#### Kit Number

46549-03, 49050-09, 49050-09A, 49155-09A, 49442-10

#### Models

For model fitment information, see the P&A Retail Catalog or the Parts and Accessories section of [www.harley-davidson.com](http://www.harley-davidson.com) (English only).

#### Additional Parts Required

##### ▲ WARNING

The rider's safety depends upon the correct installation of this kit. Use the appropriate service manual procedures. If the procedure is not within your capabilities or you do not have the correct tools, have a Harley-Davidson dealer perform the installation. Improper installation of this kit could result in death or serious injury. (00333a)

##### NOTE

*This instruction sheet references service manual information. A service manual for your model motorcycle is required for this installation and is available from a Harley-Davidson Dealer.*

#### Kit Contents

See Figures 4, 5, and 6 and Service Parts Tables.

#### REMOVAL

##### NOTE

*This instruction sheet covers several different Harley-Davidson models and years. Be sure to locate and follow the procedures that apply to the motorcycle receiving the new guard.*

#### For Models without Lower Fairings

1. Proceed to **All Models** section.

#### For Model FLHTCU with Factory-Installed Lower Fairings

1. Remove the lower fairings following the instructions in the service manual.
2. When the lower fairings have been removed, proceed to **For All Models** section.

#### For Models FLHR, FLHT or FLHTC with Harley-Davidson Genuine Motor Accessory Lower Fairings

1. See Figure 1. Remove the two screws (1) that attach the fairing cap (2) to the lower fairing (5). Remove the cap. Set the parts aside for installation.

2. Remove the screw (7), rubber washer (8), locknut (10) and the clamp (9) that attaches the bottom of the lower fairing to the engine guard and set aside.
3. Remove the two locknuts (3), U-bolt (6) and U-bolt retainer (4).
4. Remove the lower fairing by sliding it out from behind the engine guard.
5. Repeat Steps 1 through 4 for the opposite side.
6. Proceed to **All Models** section.

#### For Model FLTR with Harley-Davidson Genuine Motor Accessory Lower Fairings

##### ▲ WARNING

Disconnect negative (-) battery cable first. If positive (+) cable should contact ground with negative (-) cable connected, the resulting sparks can cause a battery explosion, which could result in death or serious injury. (00049a)

1. Disconnect the battery, negative (-) battery cable first, following the instructions in the service manual.
2. Remove the seat following the instructions in the service manual.
3. Remove the cable strap holding the clutch cable to the engine guard.
4. See Figure 2. Remove the TORX® screw (8), rubber washer (9), locknut (11) and the clamp (10) that attaches the bottom of the lower fairing (4) to the engine guard and set aside.
5. Remove the two screws (1) that attach the fairing cap (2) to the lower fairing. Remove the cap. Set the parts aside for installation.
6. Remove the screw (7), lockwasher (6) and flat washer (5) from the clamp (3) holding the top of the lower fairing to the bottom upper fairing mounting bracket (12).
7. Remove the large clamp (3) from the engine guard.
8. Remove the lower fairing from the motorcycle by sliding it out from behind the engine guard.
9. Repeat Steps 1 through 8 for the opposite side.
10. Proceed to **All Models** section.

#### All Models

1. See Figure 3. Remove and discard the two screws (4) and locknuts (5) that attach the bottom of the stock engine guard (1) to the motorcycle frame.
2. Remove and discard the hex socket screw (2) and washer (3) holding the top of the guard. Remove the engine guard from the frame, taking care not to scratch the finish on the motorcycle.



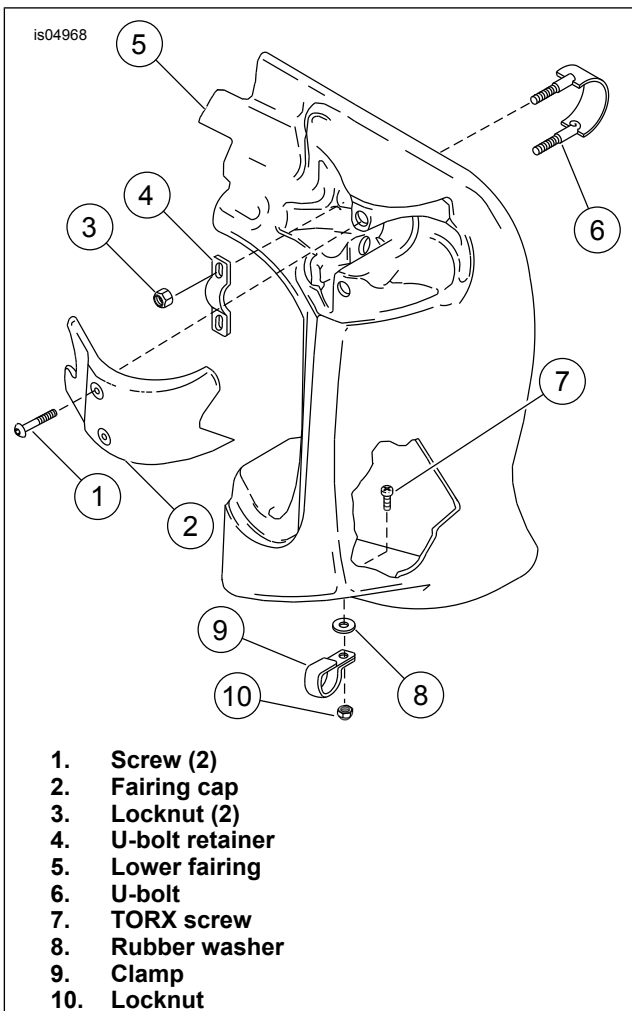

Figure 1. FLHR/I or FLHT/C/I Accessory Lower Fairing

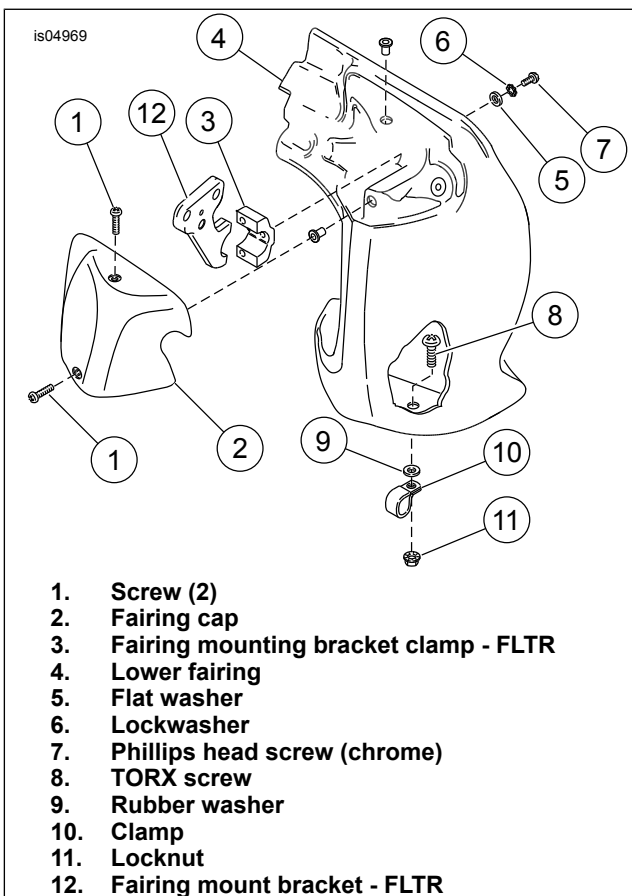

Figure 2. FLTR/I Accessory Lower Fairing

## INSTALLATION

1. Hold the engine guard in position, and loosely fasten the top of the guard with the new hex socket screw and flat washer from the kit.
2. Install the bottom brackets to the motorcycle frame with the two new TORX screws and locknuts.

### NOTE

For models without lower fairings, installation is complete.

3. For Part No. 49155-09A & 49442-10, tighten top mount screws to 30–38 N·m (22–28 ft-lbs). Tighten bottom two mounts to 20.3–27.1 N·m (15–20 ft-lbs). For Part No. 46549-03, 49050-09 & 49050-09A tighten all three screws to 20.3–27.1 N·m (15–20 ft-lbs).

### For Model FLHTCU with Factory-Installed Lower Fairings

1. Install the lower fairings following the instructions in the service manual.

### For Models FLHR, FLHT or FLHTC with Harley-Davidson Genuine Motor Accessory Lower Fairings

1. Carefully place one lower fairing in position from behind the engine guard.
2. See Figure 1. Install the lower fairing to the top of the new engine guard with the U-bolt (6) from the back, through the holes at the top of the fairing. Install the retainer (4) in position on the U-bolt and secure to the engine guard with the two locknuts (3). Do not tighten the locknuts at this time.
3. Attach the bottom of the fairing to the engine guard with the clamp (9) removed earlier. Install the clamp around the engine guard in the direction shown, with the tabs toward the rear of the vehicle and the flat side of the clamp against the lower fairing. Insert the screw (7) through the lower fairing, rubber washer (8) and clamp (9). Secure the assembly with the locknut (10). Tighten to 16.3 N·m (12 ft-lbs).
4. Tighten the locknuts (3) to 8.1 N·m (6 ft-lbs).
5. Attach the fairing cap (2) to the fairing with the screws (1) removed earlier, and tighten securely.
6. Repeat Steps 1 through 5 for the opposite side of vehicle.

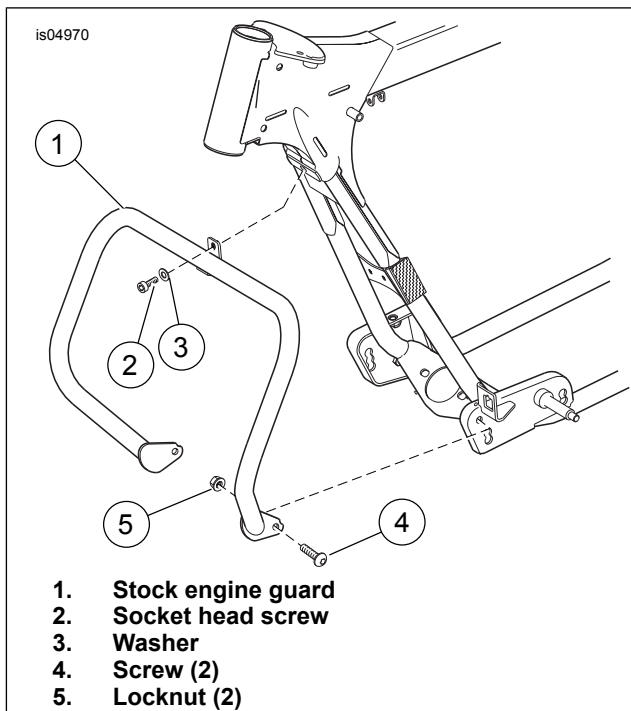

Figure 3. Install Engine Guard

## SERVICE PARTS

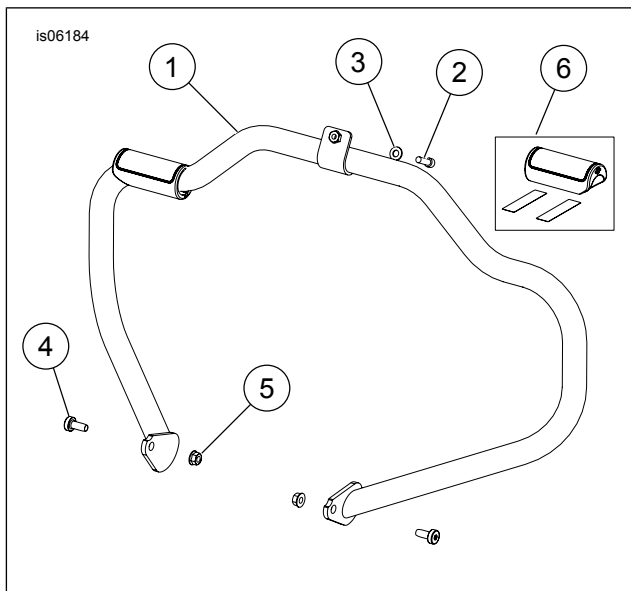

Figure 4. Service Parts: Mustache Engine Guard P/N 49155-09A, 49442-10

Table 1. Kit Contents: P/N 49155-09A, 49442-10

Item	Description (Quantity)	Part Number
1	Engine guard	Not Sold Separately
2	Screw, hex socket head 5/16-18 x 1.0 inch	2708A
3	Washer, flat 5/16	6702
4	Screw, pan head TORX®, 3/18-16 x 7/8 inch (2)	3678
5	Locknut, flanged hex 3/8-16 (2)	7601
6	Rubber pad service kit (2) (Mustache style only)	97015-09
	• Rubber foot pad (2)	
	• Adhesive tape (4)	
	• Installation pin (2)	

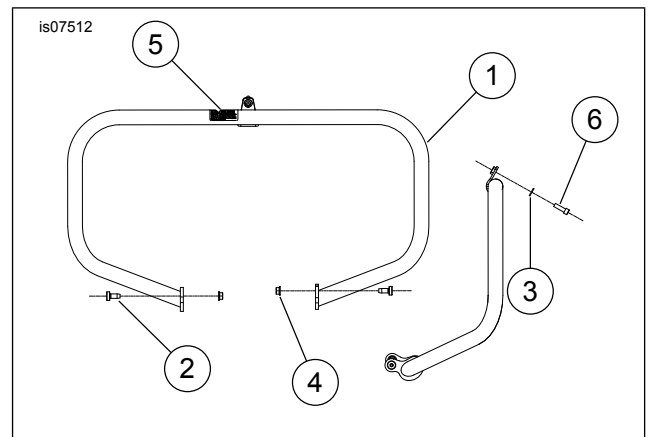

Figure 5. Service Parts: Black Engine Guard P/N 46549-03, 49050-09

Table 2. Kit Contents P/N 46549-03, 49050-09

Item	Description (Quantity)	Part Number
1	Engine guard assembly, black	Not Sold Separately
2	Flat top head tapping screw (2)	3678
3	Plain washer, type A	6702
4	Flange nut (2)	7601
5	Hex socket head cap screw	2708A

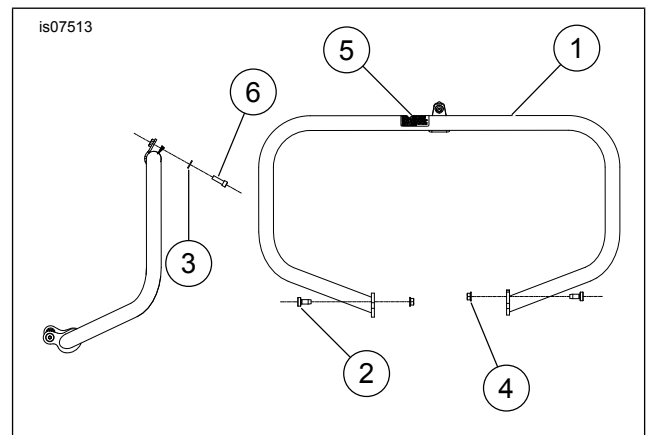

Figure 6. Service Parts: Engine Guard, Black P/N 49050-09A

Table 3. Kit Contents P/N 49050-09A

Item	Description (Quantity)	Part Number
1	Engine guard assembly, black	Not Sold Separately
2	Flat top pan head tapping screw (2)	2238
3	Washer, ferrous heat treated	6116
4	Flange nut (2)	7601
5	Hex socket head cap screw	2708A